



CATLAB

► Microreactor for Catalysis Studies & Thermal Analysis

Detailed product information / introduction

CATLAB Module 1



Catalyst Cartridge System

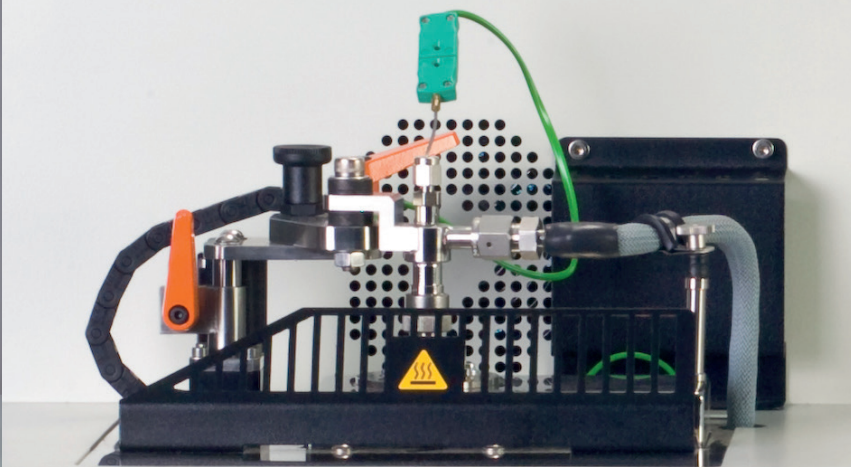

A combined bench-top microreactor and mass spectrometer system for rapid and reproducible catalyst characterisation and reaction studies.

Applications:

- ▶ TPD/TPO/TPR/TPRx
- ▶ catalysis
- ▶ catalyst screening
- ▶ pulse chemisorption
- ▶ pulse calibration
- ▶ dispersion measurements
- ▶ adsorption isotherms
- ▶ reaction studies

Key Features

- ▶ Fast response, low thermal mass furnace with integrated air-cooling
- ▶ 1-20°C/min heating rates up to 1000°C
- ▶ Hiden's unique interchangeable Catalyst Cartridge System
- ▶ Close-coupled hot-zone evolved species probe & direct QIC inlet for <500 ms response
- ▶ 'In-Bed' thermocouple for direct catalyst temperature measurement
- ▶ Automatic 4 (8 optional) gas stream manifold or combined gas/vapour manifold
- ▶ Independent Mass Flow control of each channel at 3-100 ml/min (other flow options available)
- ▶ Corrosion resistant manifold configurations also available
- ▶ Seamless on-line, real-time studies with data acquisition and PC analysis
- ▶ Air thermostat and trace heating to minimise condensation of vapour feeds/products
- ▶ Shut-off/bypass flow configuration to seal reactor and gas sampling port
- ▶ Vapour generator option for the introduction of vapours such as water, etc.

Software

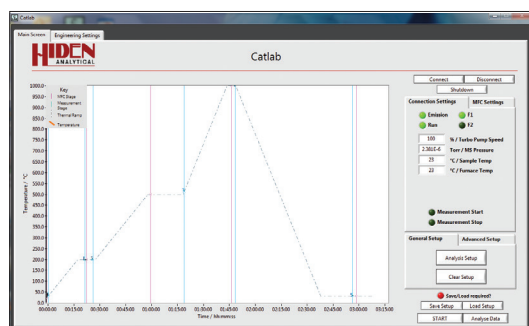

CATLAB software

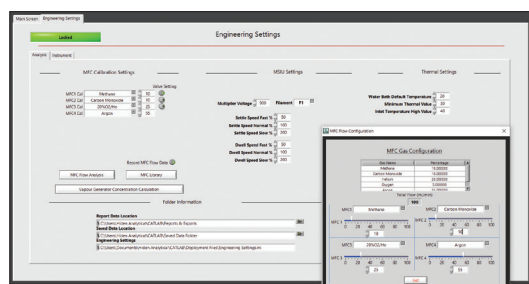

Control of MS data acquisition, MFCs, switching valves, temperature, etc.

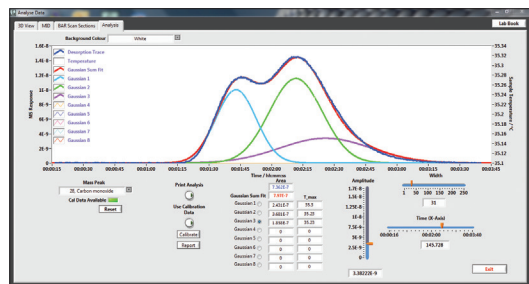

Peak integration/deconvolution

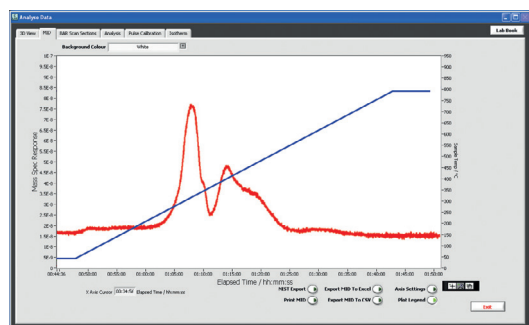

Fig. 1. Temperature Programmed Desorption

CATLAB Software

A dedicated application specific software package for automated control of MS data acquisition fully integrated with all necessary devices including MFCs, furnace temperature, switching valves, pulse injection, etc.

Key Features – CATLAB Software

- ▶ Control of the experiment following a user defined temperature profile
- ▶ MS data, temperature and flow all collected in one software package
- ▶ Data analysis routines included in the software for determination of catalyst properties such as metal surface area, dispersion, pulse adsorption isotherms, etc.
- ▶ 10 peak spectral library
- ▶ Automatic subtraction of spectral overlaps
- ▶ Analysis of up to 16 gases

CATLAB Example Data

Typical CATLAB experiments include temperature programmed studies (TPD/R/O etc.), reaction testing and pulse chemisorption. Some examples are shown:

Temperature Programmed Desorption (TPD)

Figure 1 shows the results of a TPD experiment of CO from a 1% Pd/Al₂O₃ sample. TPD experiments are performed by linearly heating a predosed sample and monitoring the evolved gases.

Key Benefits:

- ▶ High sensitivity mass spectrometer. Detection limit 100% to 100 ppb subject to spectral interference.
- ▶ Close coupled MS for synchronous detection of desorbing gas and temperature measurement.
- ▶ MS data and temperature collected in one software package.

Software (continued)

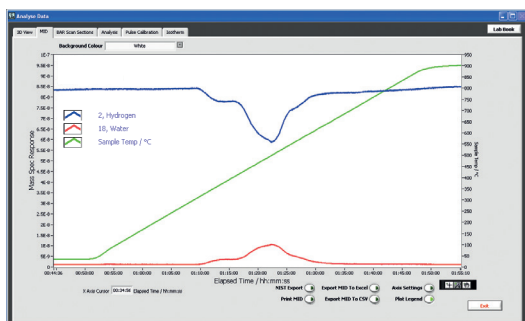

Fig. 2. Temperature Programmed Reduction

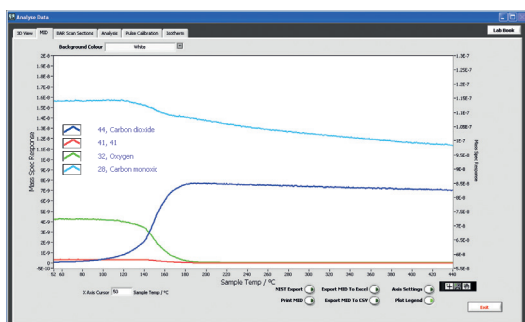

Fig. 3. Temperature Programmed Reaction

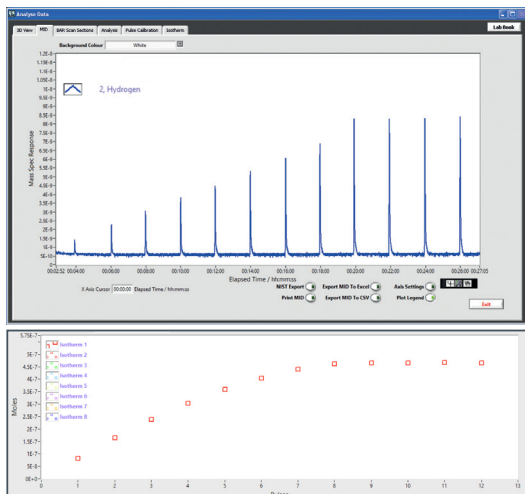

Fig. 4. Pulse Chemisorption

CATLAB Example Data (continued)

Temperature Programmed Reduction (TPR)

Figure 2 shows the results of a TPR experiment performed on a Ni sample. TPR experiments involve linear heating of the sample under a reducing atmosphere such as H₂.

Key Benefits:

- ▶ High capacity dry pumping system provides optimum performance for applications that use light gases H₂/He etc.
- ▶ Excellent H₂ sensitivity – more than x2 sensitivity for H₂ compared with published standard RS factors.
- ▶ No need for removal of condensable gases before analysis.

Temperature Programmed Reaction (TPRx)

The TPRx plot in Figure 3 shows the results of the CO oxidation light-off test ($2\text{CO} + \text{O}_2 \rightarrow 2\text{CO}_2$) during a linear temperature ramp to 500°C.

Key Benefits:

- ▶ Simultaneous measurement of up to 16 gases/mass species.
- ▶ Heated inlet for sampling of condensable gases, e.g. H₂O vapour.
- ▶ Soft Ionisation mode for simplified spectra of complex molecules.

Pulse Chemisorption

The pulse experiment shown in Figure 4 was performed over a 5% Pd/Al₂O₃ catalyst. The sample was dosed with multiple pulses of CO until saturation was achieved.

Key Benefits:

- ▶ Fast data acquisition speeds > 500 measurements/s.
- ▶ Minimal internal volumes reduce peak spreading.
- ▶ < 500 ms response time to changes in gas concentrations.

Technical Data

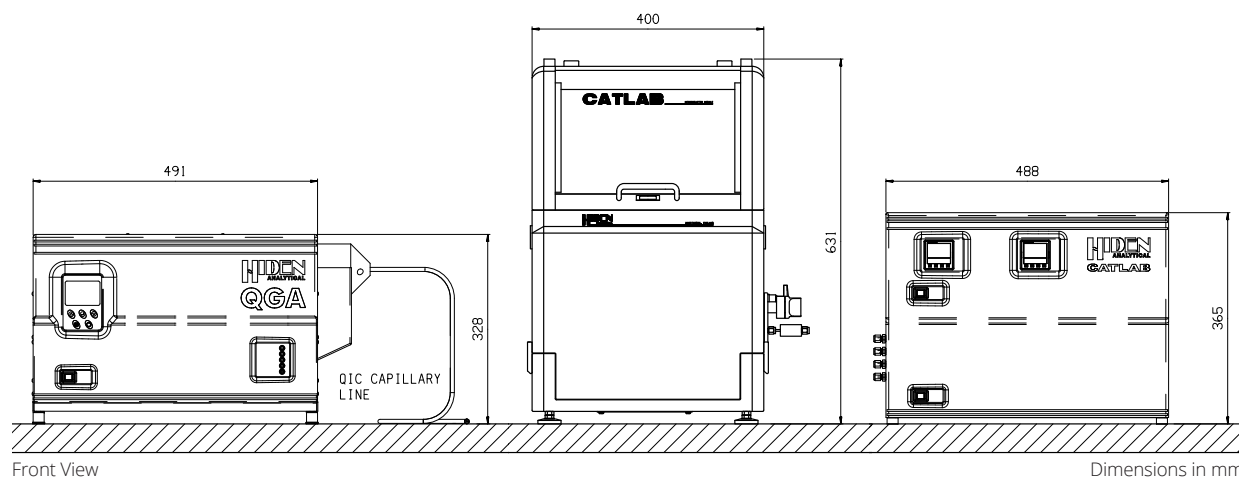

Front View

Dimensions in mm

CATLAB MODULE 1

Sample mass:

Reactor sizes (ID):

Pressure:

Temperature:

Accuracy:

Ramp Rate:

Temperature sensor:

Mass flow controllers:

Minimum flow pressure:

Port connection:

Software

Dimensions (L x W x H), mm:

Weight, kg:

Power requirement:

TECHNICAL SPECIFICATIONS

Typically 25 - 250 mg (up to 2.0 g optional)

4, 7 or 12 mm

Up to 1 bar

Ambient to 1000°C

+/- 1°C

1 to 20°C/min

Type K thermocouple

4 streams 3-100 ml/min standard
up to 8 streams with user defined flow rates optional

3 bar

1/8" Swagelok

CATLAB Software
Windows 7/8/10 compatible

Microreactor: 631 x 400 x 475 mm
Electronics Unit: 365 x 488 x 373 mm

Microreactor: 30 kg
Electronics Unit: 27kg

100-240 V AC, 50-60 Hz, 1.0 kVA

Technical Data (continued)

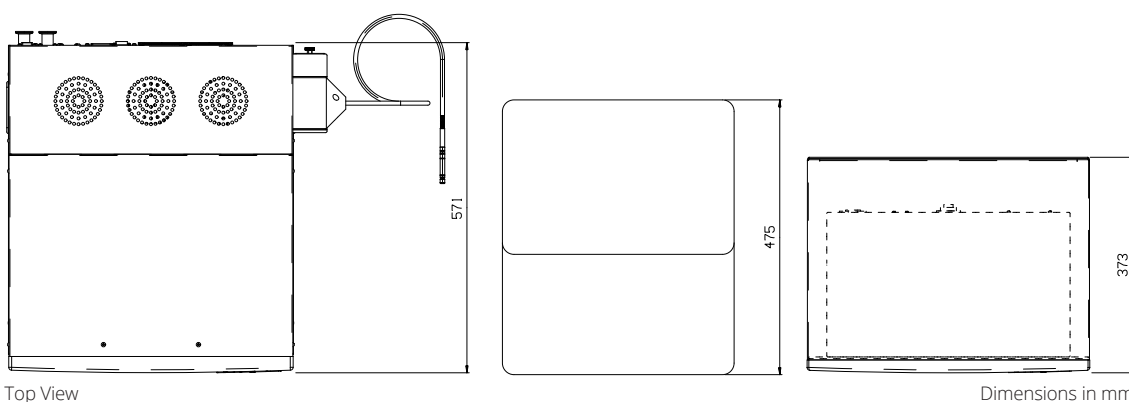

CATLAB MODULE 2

Mass range, amu:

Ion source:

Ion source control:

Detector:

Detection limit:

Gas sensitivity:

Response time:

Analyser bakeout:

Quartz Inlet Capillary:

Power requirement:

TECHNICAL SPECIFICATIONS

Standard 200 amu. Options 300 or 510 amu

Direct inlet high pressure source

All parameters adjustable in real time

Dual Faraday / Channeltron electron multiplier

5×10^{-11} torr with Faraday detector

2×10^{-14} torr with Channeltron detector

Krypton (^{84}Kr) in air at 0.5 ppm with Faraday detector

Xenon (^{129}Xe) in air at 25 ppb with Channeltron detector

300 ms

250°C

Typical inlet flow rate/gas consumption 20 atm ml/min

Low flow rate versions to 1 atm ml/min available

100-240 V AC, 50-60 Hz, 1.5 kVA

FURTHER SYSTEM OPTIONS

Corrosion resistant upgrade for Modules 1 & 2

Vapour generator

System Configuration & Options

ITEM	DESCRIPTION	PARTCODE
SYSTEM	CATLAB - PCS Module 1: The Microreactor System A Quartz Microreactor with integrated low thermal mass, air-cooled radiant furnace and close-coupled QIC sampling. This item includes the CATLAB - PCS Windows® software and computer control of temperature (ramp/set-point) and flow. Low thermal mass furnace for linear ramp control and set-point regulation to 1000°C: Includes a high temperature quartz sample reactor for operation to 1 bar with high temperature sensors and interface.	303230
	CATLAB - PCS module 2: The QGA Mass Spectrometer A QGA bench-top gas analysis system, including Hiden HAL 201 RC mass spectrometer with dual Faraday/Channeltron Electron Multiplier detector. Mass range 200 amu. Includes external scroll pump. QGA Professional & MASsoft Professional software packages included as standard. Includes standard QIC capillary inlet for operation up to 200°C	305110
OPTIONS & ACCESSORIES	Corrosion resistant upgrade	303250
	Corrosion resistant upgrade - additional feed stream	303255
	8 Flow Stream option. Additional 4 channel MFC flow control unit integrated to provide 8 stream gas selection.	303258
	Vapour feed system	303259
	Extended mass range. 300 amu mass range (in place of standard 200 amu mass range)	305113
SPARES KIT	Mass spectrometer spares QGA Mass Spectrometer Spares kit including: <ul style="list-style-type: none"> ▶ Replacement capillary liner ▶ Replacement capillary leak orifice ▶ Twin filament 	303148
	Microreactor spares CATLAB module 1 maintenance kit. Includes replacement 'O' ring seals and tools	3101210
	CATLAB reactor tube. Precision quartz reactor tube assembly with integral gas sampling tube	3101012
	CATLAB sample tube kit. Includes 6 sample tubes, preparation tool, quartz wool and 'O' ring	3101016
	PCS - Additional valve sample loop	303260

Hidden **APPLICATIONS**

Hidden's quadrupole mass spectrometer systems address a broad application range in:

GAS ANALYSIS

- ▶ dynamic measurement of reaction gas streams
- ▶ catalysis and thermal analysis
- ▶ molecular beam studies
- ▶ dissolved species probes
- ▶ fermentation, environmental and ecological studies

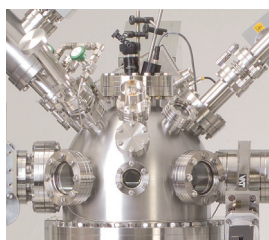

SURFACE ANALYSIS

- ▶ UHV TPD
- ▶ SIMS
- ▶ end point detection in ion beam etch
- ▶ elemental imaging – 3D mapping

HIDDEN

ANALYTICAL

Hidden Analytical Ltd.
420 Europa Boulevard
Warrington WA5 7UN England

T +44 [0] 1925 445 225
F +44 [0] 1925 416 518
E info@hidden.co.uk
W www.HiddenAnalytical.com



Sales Offices:

We have sales offices situated around the globe. **Visit our website for further information.**



PLASMA DIAGNOSTICS

- ▶ plasma source characterisation
- ▶ etch and deposition process reaction kinetic studies
- ▶ analysis of neutral and radical species



VACUUM ANALYSIS

- ▶ partial pressure measurement and control of process gases
- ▶ reactive sputter process control
- ▶ vacuum diagnostics
- ▶ vacuum coating process monitoring