



SurfaceVue 10

Fixed-Location, Non-Invasive
Road Surface Condition Sensor



Please read first

About this manual

Please note that this manual was produced by Campbell Scientific Inc. primarily for the North American market. Some spellings, weights and measures may reflect this. In addition, while most of the information in the manual is correct for all countries, certain information is specific to the North American market and so may not be applicable to European users. Differences include the U.S. standard external power supply details where some information (for example the AC transformer input voltage) will not be applicable for British/European use. Please note, however, *that when a power supply adapter is ordered from Campbell Scientific it will be suitable for use in your country.*

Reference to some radio transmitters, digital cell phones and aerials (antennas) may also not be applicable according to your locality. Some brackets, shields and enclosure options, including wiring, are not sold as standard items in the European market; in some cases alternatives are offered.

Recycling information for countries subject to WEEE regulations 2012/19/EU



At the end of this product's life it should not be put in commercial or domestic refuse but sent for recycling. Any batteries contained within the product or used during the products life should be removed from the product and also be sent to an appropriate recycling facility, per [The Waste Electrical and Electronic Equipment \(WEEE\) Regulations 2012/19/EU](#). Campbell Scientific can advise on the recycling of the equipment and in some cases arrange collection and the correct disposal of it, although charges may apply for some items or territories. For further support, please contact Campbell Scientific, or your local agent.

Table of contents

1. About SurfaceVue 10	1
2. Precautions	2
3. Initial inspection	2
4. Overview	3
5. Operating principles	3
6. Technical specifications	4
7. Installation	6
7.1 Installation height and angle	6
7.2 Install sensor	7
7.3 Wiring	10
7.3.1 RS-232	11
7.3.2 RS-485	11
7.4 CRBasic programming	12
7.5 Data format	14
8. Maintenance	15
9. Calibration	17
9.1 While connected to Campbell Scientific data logger	17
9.2 While connected directly to a computer	17
10. Troubleshooting	18
11. Frequently asked questions	19
11.1 How do I calculate the distance from the sensor to the measuring area on the road?	19
11.2 How do I calculate the installed angle?	20
11.3 Can I calibrate the sensor remotely?	20
11.4 What is the definition of ground temperature?	20
11.5 What type of structure should the SurfaceVue 10 be mounted to?	20
11.6 Does the SurfaceVue 10 need to be continuously powered?	20

1. About SurfaceVue 10

The SurfaceVue™10 is a non-invasive road condition sensor used by road weather professionals to provide vital information about their road network to make better maintenance and operational decisions. The SurfaceVue 10 sensor consists of two non-invasive road weather sensors designed for use with your Road Weather Information System (RWIS). The CS981 is enclosed in a white radiation shield and mounted on top of the CS991, which is in a black tube. The CS981 measures surface temperature, air temperature, relative humidity, and air pressure. The measured air temperature and relative humidity are used to calculate dew point. Ground temperature and wind speed are modeled. The CS991 uses spectroscopic analysis to provide you with surface state, grip (friction), and water and ice layer thickness data. The measured data is communicated to a data logger over RS-232 or optionally over RS-485 using an RS485EXT converter box.

NOTE:

Ground temperature is the temperature below the road surface at 6 cm (2.4 in) depth.

Road surface condition is determined by the presence and amount of ice or water on the road surface. From these measurements, the built-in model determines the coefficient of friction, which corresponds to the grip between the road surface and vehicle tires. The model is developed by using braking deceleration measurements as a reference. Comparison tests indicate about 0.10 units as standard deviation of the difference to the reference. Very thin layers and mixed ice/water layers may occasionally lead to larger differences. All the data is updated approximately every 10 seconds.

The analyzed road surface state is reported as:

1. Dry
2. Moist
3. Wet
4. Slush, ice or snow with water
5. Ice
6. Snow or hoar frost.

After power-up or reset, the SurfaceVue 10 sends a wake-up string containing the sensor name and version information. Approximately 10 seconds after the initial message, it automatically sends a data message when a measurement/calculation cycle is complete; typically, once every 10 seconds. A data logger with the SurfaceVue 10 program, see [CRBasic programming](#) (p. 12), is

used to log data every minute and can perform a dry calibration under user control, see [Calibration](#) (p. 17).

2. Precautions

- READ AND UNDERSTAND the [Safety](#) section at the back of this manual.
- Use caution when working near roadways and moving vehicles. Coordinate with local traffic authorities and use appropriate traffic control measures.
- Although the SurfaceVue 10 is rugged, it should be handled as a precision instrument.
- Do not use RS-232 cable lengths greater than 10 m. For longer communications distances, an RS-485 extender kit, which converts RS-232 to RS-485 should be used.
- Follow local regulations. See Compliance in [Technical specifications](#) (p. 4).
- IMPORTANT: The SurfaceVue 10 should be calibrated when the surface is dry, and it should be re-calibrated after installation, if the distance to target is changed, or the surface type is changed, such as road resurfacing.
- Protect from ESD (electrostatic discharge).

Symbol	Description
	Caution. See Install sensor (p. 7) and Safety .

3. Initial inspection

- Upon receipt of the SurfaceVue 10, inspect the packaging and contents for damage. File any damage claims with the shipping company.
- The model number and cable length are printed on a label at the connection end of the cable. Check this information against the shipping documents to ensure the expected product and cable length are received.

4. Overview

The SurfaceVue 10 is simple to install on new and existing infrastructure. Each sensor is supplied with a mounting bracket and two band clamps suitable for mounting the sensor to a vertical pole with diameters between 70 and 170 mm (3 and 7 in).

Features include:

- Accurate measurements
- Non-invasive
- Easy to install
- Simple to maintain
- Remote OS update via data logger
- Compatible with most data loggers and RWIS
- Monitor troublesome areas, such as bridge decks
- Ideal for multiple uses, including roads, parking lots, cycleways, and sidewalks

5. Operating principles

The SurfaceVue 10 unit is equipped with a thermopile sensor that detects the presence of thermal radiation emitted from the target surface. Additionally, it uses optical measurements to detect water and ice. The measuring light is not visible to the human eye. The light reflection from the measured surface depends on the surface material and contamination on the window surface. The measurement method is optimized for a standard stony asphalt surface. The signal levels of the SurfaceVue 10 unit are factory calibrated for a dry surface. Water and ice on the road surface attenuate the reflected light as compared to the calibrated values. The degree of signal attenuation depends on the amount of ice or water. The measurement system is optimized for thin layers, because very thin layers (50 μm) of ice can significantly reduce grip. Thick layers (≥ 4 mm) of water may attenuate the signal too much for a reliable measurement. A continuous layer of water on ice may also result in a false state and elevated grip value. Fortunately, this is not a very common condition on road surfaces.

The SurfaceVue 10 is eye safe for infra-red radiation according to the standard EN 60825-1:2007.

6. Technical specifications

Road conditions

Surface states: Dry, moist, wet, slush, snow, ice

Field of view (FOV)

Road surface conditions: 2.8° (0.5 m at 10 m)

Road surface temperature: 10° (1.7 m at 10 m)

Grip (friction)

Measurement range: 0 to 1.0 (unitless)

Accuracy: ± 0.1 (compared to braking friction reference)

Resolution: ± 0.01

Water and ice layer thickness

Range: 0 to 3 mm (0 to 0.12 in)

Accuracy:

- ± 0.1 mm up to 1.0 mm (0.004 in up to 0.04 in)
- 10% above 1.0 mm (0.04 in)

Resolution: ± 0.01 mm

Road surface temperature

Measurement range: -40 to $+60$ °C (-40 to $+140$ °F)

Accuracy -40 to 60 °C: ± 0.3 °C

Resolution: ± 0.1 °C

Ground temperature (modeled)

Measurement range: -40 to $+60$ °C (-40 to $+140$ °F)

Accuracy -40 to 60 °C: ± 0.5 °C

Resolution: ± 0.1 °C

Dew point temperature (calculated)

Measurement range: -40 to $+60$ °C (-40 to $+140$ °F)

Accuracy -40 to 60 °C: ± 1.0 °C

Resolution: ± 0.1 °C

Air temperature

Measurement range:	-40 to +60 °C (-40 to +140 °F)
Accuracy:	±0.3 °C
Resolution:	±0.1 °C

Relative humidity

Measurement range:	0 to 100%
Accuracy:	±2%
Resolution:	±0.1%

Barometric pressure

Measurement range:	500 to 1100 hPa
Accuracy:	±1.0 hPa
Resolution:	±0.1 hPa

Wind speed (modeled)

Measurement range:	0 to 60 m/s (0 to 134 mph)
Accuracy:	±10%
Resolution:	±1 m/s

General specifications

Measurement range:	3 to 10 m (9.8 to 32.8 ft)
Installation angle:	30 to 80°
Operating temperature range:	-40 to 60 °C (-40 to 140 °F)
Operating humidity range:	0 to 100%
Power consumption @ 12 VDC:	<100 mA (typical)
Supply voltage range:	9 to 30 VDC
Digital output:	RS-232, RS-485 (with RS485EXT)
Warm-up time:	1 min
Cable type:	Five conductor
Cable length:	10 m (32.8 ft)
Dimensions, excluding band clamp (length x height x depth):	76.2 x 27.9 x 17.8 cm (30 x 11 x 7 in)

Weight: 4.9 kg (10.8 lb)

Compliance: View documents at:
www.campbellsci.com/surfacevue10 

7. Installation

The SurfaceVue 10 is designed to measure asphalt or concrete road or runway surfaces. It is typically installed permanently to a large pole or lattice tower and aimed at the measuring surface. There are multiple sensors to consider when choosing a location and installing the sensor. These sensors include the surface condition optics, infrared temperature, air temperature, and dew point.

Installation considerations:

- Distance from sensor to measuring area of road is within 3 to 10 meters (10 to 33 ft). The preferred distance is 3 to 7 meters (10 to 23 ft). See [How do I calculate the distance from the sensor to the measuring area on the road?](#) (p. 19).
- Mounting angle is within 30 to 80°. The preferred angle is 45 to 80°. See [How do I calculate the installed angle?](#) (p. 20).
- Avoid solar reflections into the sensor detector hood. It is recommended to mount the sensor facing north in the northern hemisphere.
- Avoid existing or potential obstructions between the sensor and roadway, such as snowbank buildup blocking the sensor signal.
- Avoid cracks or painted lines in the pavement within the sensor field of view.
- Select a site away from intersections and where there is not regularly stopped traffic.

7.1 Installation height and angle

Installation height and angle affect the surface measurement area. Use an online field of view tool <https://docs.wintersense.com/field-of-view/>  to see how these factors affect the field of view, and consequently the section of road surface being measured.

The recommended installation height for a SurfaceVue 10 smart sensor is 3 to 5 meters (10 to 16 feet). Sensors can be installed higher if required. However, the higher the sensor is installed, the larger the surface measurement area will be. This increases the risk of sensing the temperature of unwanted objects. In addition, a large measuring distance may result in reduced accuracy under

certain atmospheric conditions. See [How do I calculate the distance from the sensor to the measuring area on the road?](#) (p. 19) for more information.

The following table and figure show typical installation parameters and resulting target dimensions.

Installation parameter	Surface temperature	Surface condition
Angle (α)	45°	
Sensor setback (B)	3 m (10 ft)	
Sensor height (H)	3 m (10 ft)	
Field of view (FOV)	10°	2.8°
Calculated target dimensions:		
Distance to target (D)	4.3 m (14 ft)	
Target coverage area (A)	0.64 m ² (6.9 ft ²)	0.05 m ² (0.5 ft ²)
Major (long) diameter (L)	1.1 m (3.5 ft)	0.3 m (1.0 ft)
Minor (short) diameter (S)	0.8 m (6.9 ft)	0.2 m (0.7 ft)

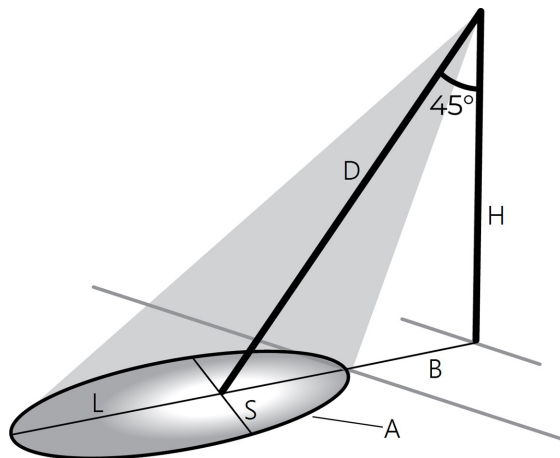

7.2 Install sensor

The SurfaceVue 10 installation kit includes brackets, metal bands, and mounting hardware needed to secure it to a pole. The metal bands are routed over the brackets, and then around a vertical pole. They are anchored in place using screw clamps.

Recommended equipment and supplies:

- 7 mm (9/32 in) hex tool or slotted screwdriver (not supplied) for adjusting band clamp
- 13 mm (1/2 in) spanner, wrench, or socket to allow sensor angle adjustment
- Clean lint-free cloths
- Laser pointer (optional accessory)

Attach the bracket to a vertical post as follows:

1. Feed a metal band around the bracket top and bottom. Insert the tab on the end of the screw threads into the hole at one end of the strap. Tighten enough so the bands stay in place but can be moved vertically.
2. Position the bracket at the SurfaceVue 10 desired height and facing the road surface.



3. Pull the strap tight around the pole and bracket.
4. Use metal shears to remove any excess strap, leaving a small amount for adjustments.
5. Using a flathead screwdriver or nut driver, tighten the screw clamp.
6. Attach the SurfaceVue 10 to the bracket using two bolts. Finger tighten the nuts.
7. Route the sensor cable from the sensor, down the pole and to the enclosure. Use cable ties to secure in place.

8. Select the angle of the sensor support arm so that the sensors point to a desired spot of measurement on the road. Turn on the laser pointer. Gently slide the laser pointer into the surface-temperature sensor tube. Adjust the sensor angle to point it at the road surface to be measured.

DANGER:

Never shine a laser pointer at anyone. Do not point a laser pointer at mirror-like surfaces.



9. Gently remove the laser pointer from the tube, and turn it off. Take care to not change the sensor angle.

10. Check the rotation of the CS991 sensor in the tube as shown in the following figure. The two smaller lenses of the sensor should be in line with the road surface.

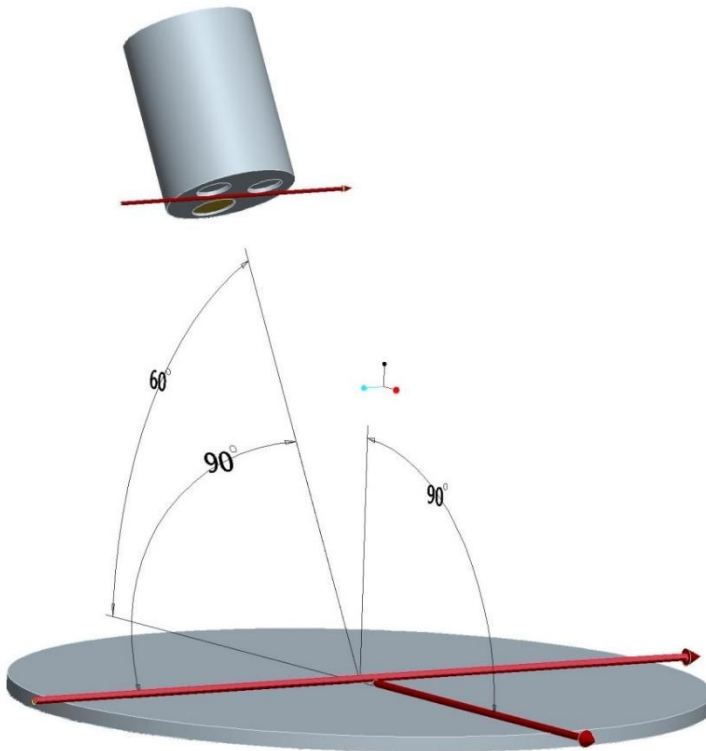

11. Once the sensor is oriented correctly tighten the bracket nuts.

7.3 Wiring

The SurfaceVue 10 cable terminates in individual wires. Connect the wires to the data logger in the order shown in the following sections.

Also see [Does the SurfaceVue 10 need to be continuously powered?](#) (p. 20).

7.3.1 RS-232

SurfaceVue 10 Wire color	Wire function	Data logger connection
White	Receive signal (Rx)	C odd
Black	Transmit signal (Tx)	C even
Brown	Power 9 to 30 VDC	12V
Blue	Ground	G
Yellow	Not used	Not connected

7.3.2 RS-485

An RS485EXT box, as shown in the following figure, is required to convert the RS-232 signals to RS-485. See <https://www.campbellsci.com/rs485ext> for more information. Using a flat-bladed screwdriver press firmly in the small square slot to open the wire slot. Insert the end of the wire into the wire slot. Remove the screwdriver to close the wire slot. Repeat with the other wires.

TIP:

Wires with ferrules can be pressed firmly into the wire slot. You do not need to open it first.

Wire color (SurfaceVue 10)	RS485EXT connection	Data logger connection
White	RS232 Rx	
Black	RS232 Tx	
Brown	RS232 12VDC (power)	
Blue	RS232 G	
Yellow	Not used	
Clear	⏏	
	RS485 A(-)	C odd
	RS485 B(+)	C even
	RS485 12VDC (power 10 to 30 VDC)	12V
	RS485 Ground	G
	⏏	⏏

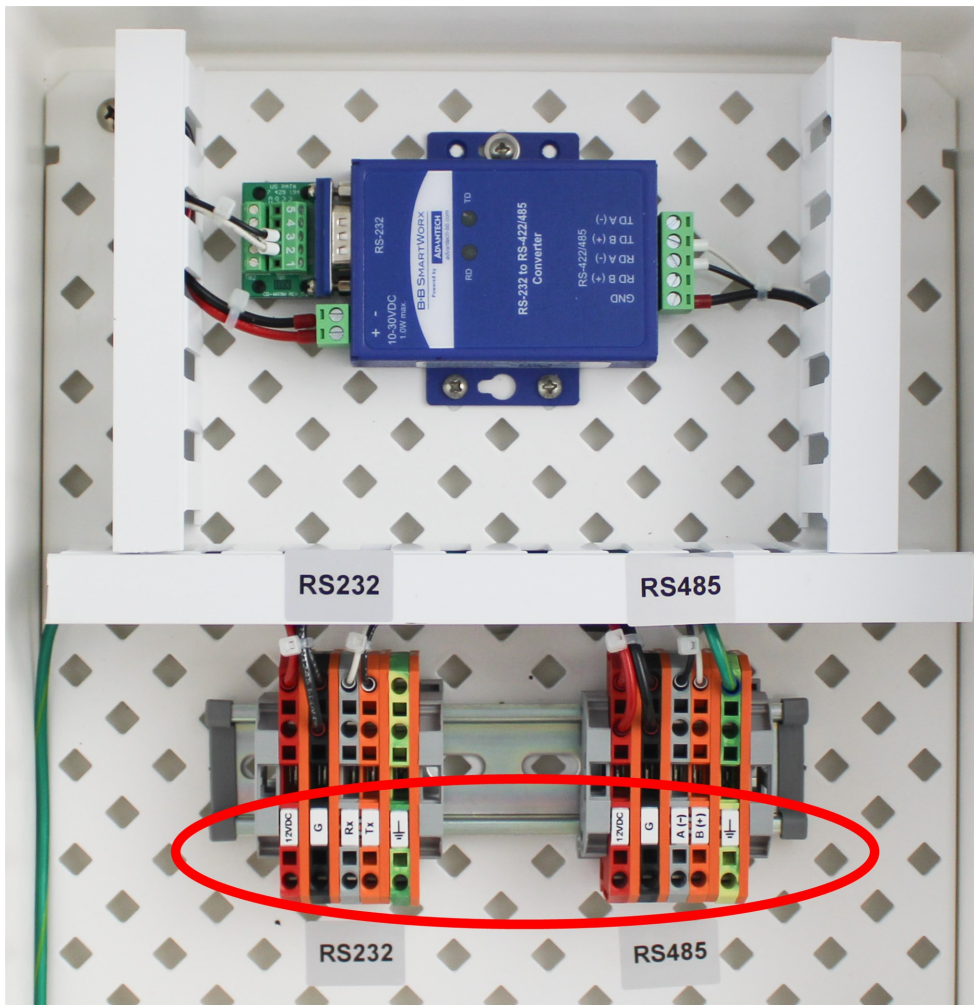

7.4 CRBasic programming

Downloadable example programs are available at <https://www.campbellsci.com/downloads/surfacevue10-example-program>

The `SerialOut()`, `SerialIn()`, and `SerialInRecord()` instructions program a data logger to communicate with the SurfaceVue 10 using RS-232. Use `SplitStr()` to separate the returned data.

NOTE:

The standard serial configuration is RS-232, 38400 baud, 8N1. The optional RS485EXT converter box has the same serial configuration.

There are three constants that can be edited before sending the SurfaceVue 10 program to the data logger.

- **ScanInterval** – This changes the scan interval of the main program. Time in seconds. Default is 30 seconds.
- **SurfaceVue_RS232** - This sets the communications protocol the data logger will use to retrieve data, calibrate, and set configuration parameters. The sensor has native RS-232 communications. RS-485 is used when the RS485EXT is used. Set to **true** for RS-232 and **false** for RS-485. Default is true for RS-232.
- **SurfaceVue_Port** – This sets the com port the sensor is wired to on the data logger. Options are **ComC5**, **ComC7**, **COMRS232**, **32** to **47** (SDM device addresses).

There are subroutines included in the program to simplify interacting and collecting data from the sensor. The user should have permissions and know how to edit variables in the data logger **Public** table.

- **SurfaceVueCalDry** – Subroutine to initiate a dry calibration. The road or runway surface being measured should be dry when initiating this command. Set the **SurfaceVueCalDry** variable to a value of **1** in the Public table. When the calibration is completed the **SurfaceVue_Drystring** variable will populate with the results of the calibration. Verify that the condition value is dry and the friction value is the expected dry value of 0.81.
- **SurfaceVueConfRead** - Subroutine to read the configuration (**CONF**) of the sensor. Set the **SurfaceVueConfRead** variable to a value of **1** in the Public table. The output of the **CONF** string will display in the **SurfaceVue_Confstring** variable.
- **SurfaceVueConfWrite** - Subroutine that will allow the user to write a configuration (**CONF**) variable to the sensor. This should only be used when instructed by Campbell Scientific. Enter the **CONF** variable to be changed in the **SurfaceVue_ConfigNumber** variable. This is an integer number between **1** and **13**. Enter the value of the configuration parameter to be changed in the **SurfaceVue_ConfigValue** variable. Next, set the **ConfWriteFlag** variable to a value of **1**. The **SurfaceVue_Confstring** will populate with the new configuration to confirm the change.
- **SurfaceVueRead** – Subroutine to read the automatic output from the sensor and parse it into variables for data output.

7.5 Data format

The SurfaceVue 10 automatically outputs a new data message approximately once every 10 to 20 seconds. The data is comma separated ASCII ending with CR + LF:

```
RCM411R V 0.80 2020-03-18
```

```
0.037, 0.108, -0.003, 0.60, 0, 22.3, -5.8, 21.08, 248.6, 0.00, 21.11, 0.00,
1.025,1010.51, 7.3, 8.7
0.031, 0.107, -0.002, 0.60, 3, 22.3, -5.8, 21.13, 248.7, 0.71, 21.11, 0.00,
1.040,1010.47, 7.3, 8.7
0.029, 0.107, -0.002, 0.60, 3, 22.2, -5.8, 21.16, 248.7, 0.70, 21.11, 0.00,
1.047,1010.53, 7.3, 8.7
0.307, 0.122, -0.021, 0.61, 3, 22.3, -5.8, 21.16, 248.7, 0.72, 21.11, 0.00,
0.794,1010.50, 7.3, 8.8
0.648, 0.141, -0.038, 0.61, 3, 22.2, -5.8, 21.16, 248.7, 0.74, 21.11, 0.00,
0.604,1010.56, 7.3, 8.8
0.965, 0.159, -0.013, 0.61, 3, 22.2, -5.8, 21.21, 248.7, 0.76, 21.11, 0.00,
0.490,1010.54, 7.3, 8.8
1.257, 0.175, -0.014, 0.61, 3, 22.2, -5.8, 21.19, 248.7, 0.78, 21.11, 0.00,
0.415,1010.42, 7.3, 8.8
1.519, 0.190, -0.016, 0.61, 3, 22.3, -5.7, 21.13, 248.7, 0.80, 21.11, 0.00,
0.364,1010.50, 7.4, 9.5
1.755, 0.203, -0.019, 0.62, 3, 22.2, -5.8, 21.07, 248.7, 0.81, 21.11, 0.00,
0.326,1010.42, 7.4, 9.9
... ..
```

The first line is only generated once after the sensor is turned on. The comma separated value descriptions are shown in the following table.

	Description	Unit	Typical value
1	Internal use	N/A	0.031
2	Internal use	N/A	0.107
3	Internal use	N/A	-0.002
4	Grip	unitless	0.60
5	Road condition index: 1 = dry 2 = moist 3 = wet 4 = slush 5 = ice 6 = snow/frost	unitless	3

	Description	Unit	Typical value
6	Air temperature	°C	22.3
7	Dew point	°C	-5.8
8	Road temperature	°C	21.13
9	Internal use	N/A	248.7
10	Internal use	N/A	0.71
11	Ground temperature	°C	21.11
12	Ice thickness	mm	0.00
13	Water depth	mm	1.040
14	Barometric pressure	hPa	1010.47
15	Wind speed	m/s	7.3
16	10-minute maximum wind gust	m/s	8.7

8. Maintenance

DANGER:

Before attempting any maintenance on the sensor, refer to the [Safety](#) section. Study the sections on working at height, use of batteries, and exposure to radio transmitters.

CAUTION:

Before proceeding with any maintenance, always retrieve the data first.

CAUTION:

Always disconnect the SurfaceVue 10 from the data logger or the connector before disassembling.

Recommended equipment and supplies:

- 7 mm (9/32 in) hex tool or slotted screwdriver (not supplied) for adjusting band clamp
- 13 mm (1/2 in) spanner, wrench, or socket to allow sensor angle adjustment
- Clean lint-free cloths or lens tissues
- Bulb air blower suitable for camera lenses

- Cotton buds or swabs
- Electronics-grade alcohol or suitable glass cleaner
- Distilled water

The SurfaceVue 10 is designed to require minimal annual maintenance. Recommended maintenance includes:

- Check the cleanness of the surface-condition sensor window. Use a bulb air blower to remove any large contaminants from the lens. Clean the lens with a lint free lens cloth or lens tissue. Detergents suitable for cleaning glass can be used, when necessary.
- Check the window of the surface-temperature sensor. Use a bulb air blower to remove any large contaminants from the lens. Use a long cotton swab and wet with distilled water to clean the window and then wipe it dry.
- Check the air temperature and relative humidity measurements. If you suspect an error in either of those measurements, or the dew point calculation, the sensor may need to be serviced by the manufacturer.
- Check the calibration. See [Calibration](#) (p. 17) for more information.

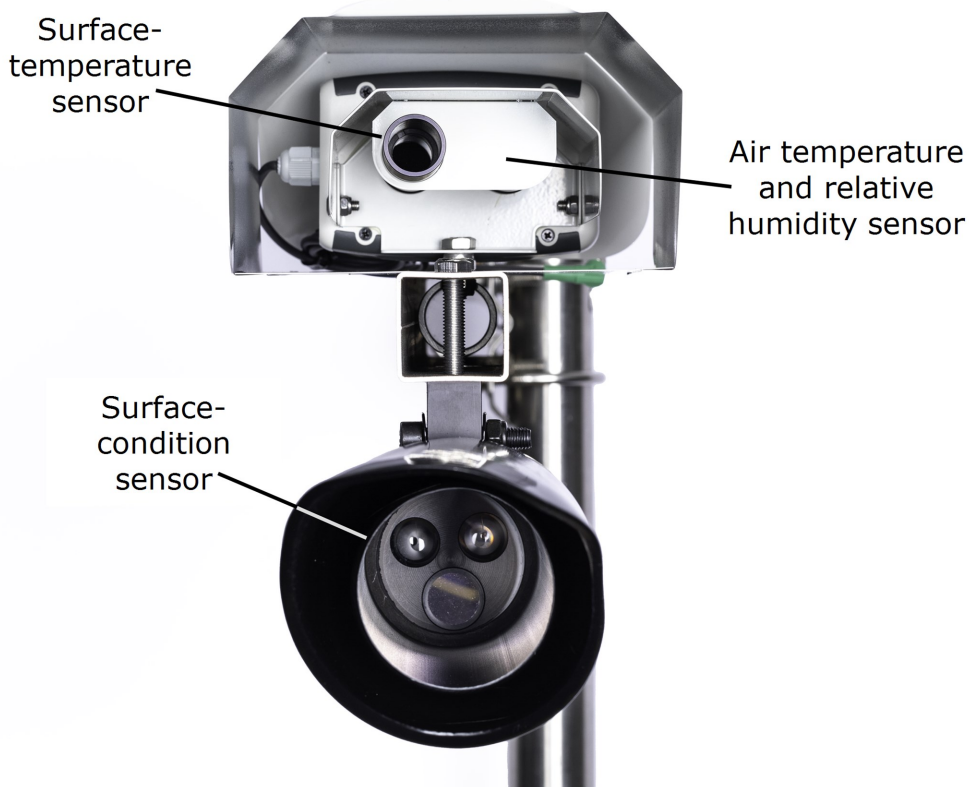

9. Calibration

There are several settings in the SurfaceVue 10 sensor. However, only the **Grip** reading of a fully dry surface is relevant; it should read close to **0.81**. The other sensor readings are factory calibrated for specified performance. If there is a need to adjust these readings, consult Campbell Scientific.

The SurfaceVue 10 is factory calibrated for a dry road surface at a distance of about 5 m from the sensor to the measurement spot. When the calibration is correct and the sensor window is clean, the **Road condition index** should report **Dry** and **Grip** should be near **0.81** for a completely dry surface.

NOTE:

It is a good practice to recalibrate the sensor after installation.

9.1 While connected to Campbell Scientific data logger

To calibrate the sensor using the program provided, and when the surface is known to be dry, set the **CalDryFlag** to **true**. For more information, see [CRBasic programming](#) (p. 12).

9.2 While connected directly to a computer

Tera Term (www.teraterm.org) or similar software can be used on a computer to communicate with the SurfaceVue 10. A compatible RS-232 to USB serial adapter is used to connect the sensor to the computer.

1. Connect the sensor RS-232 Rx, Tx, and ground wires to the serial converter connected to a computer.
2. Connect the power wires to an appropriate power supply.
3. Open *Tera Term* or similar software and configure it to an RS-232 serial connection at 38400 baud and 8N1.
4. Open the connection.
5. To start communicating with the sensor send it the "**open<enter><esc>**" command. It should respond with ">" and "**OPENED**". Repeat the command if this does not work.

6. To calibrate the sensor on a dry road surface, type "dry 2 <enter>".
7. The sensor will automatically close the connection and start reporting the data string.

Example:

```

open
>
OPENED
>dry 2
DRY = 0.603 0.075
>
CLOSED
RCM411R test 0.87 2022-01-05
0.031, 0.107, -0.002, 0.60, 3, 22.3, -5.8, 21.13, 248.7, 0.71, 21.11, 0.00,
1.040,1010.47, 7.3, 8.7
0.029, 0.107, -0.002, 0.60, 3, 22.2, -5.8, 21.16, 248.7, 0.70, 21.11, 0.00,
1.047,1010.53, 7.3, 8.7

```

10. Troubleshooting

Symptom	Possible cause	Solution
The friction value of dry pavement has decreased over time.	This can indicate that the optics are dirty, or the pavement has changed.	Clean the optics then initiate a dry calibration. See Maintenance (p. 15) and Calibration (p. 17).
No data is being reported or there are NAN readings in real-time or stored data.	This indicates the terminal program or data logger is not receiving data from the SurfaceVue 10.	<p>Check that the main sensor cable connector on the back of the condition unit (CS991) is installed correctly and hand tight.</p> <p>Check that the sensor is wired to the correct terminals specified by SerialIn(). See Wiring (p. 10)</p> <p>Check the voltage to the sensor with a digital voltage meter. See the Supply voltage range in Technical specifications (p. 4).</p>

Table 10-1: Symptoms, possible causes, and solutions

Symptom	Possible cause	Solution
Data string is reporting data from the surface condition sensor but not from the temperature sensor.	The connection cable between the sensors may be connected incorrectly.	Remove the surface-condition sensor end cap and check that the connector is installed correctly and hand tight.

11. Frequently asked questions

11.1 How do I calculate the distance from the sensor to the measuring area on the road?

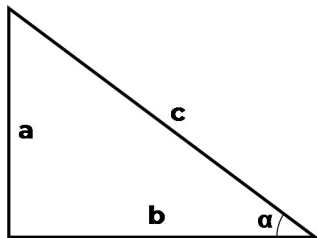

Figure 11-1. Right triangle

Where:

c = distance from the head of the sensor to the measuring area on the road

b = distance from the measuring area on the road to the base below the head of the sensor

a = distance from the base below the head of the sensor to the head of the sensor

α = measuring angle

1. Measure the distances **a** and **b**.
2. Calculate **c** using the following equation:

$$c = \sqrt{a^2 + b^2}$$

3. See [Technical specifications](#) (p. 4) for **Measurement range** requirements.

11.2 How do I calculate the installed angle?

1. Refer to previously shown [Figure 11-1](#) (p. 19)
2. Calculate α using the following equation:

$$\alpha = \arcsin(a/c)$$

3. See [Technical specifications](#) (p. 4) for **Installation angle** requirements.

11.3 Can I calibrate the sensor remotely?

Yes, the SurfaceVue 10 can be calibrated remotely when connected to a Campbell Scientific data logger. The calibration must be completed when the road is dry. This can be determined from data of other sensors located on the weather station or from a camera image if available. See [Calibration](#) (p. 17).

11.4 What is the definition of ground temperature?

Ground temperature is the temperature below the road surface at 6 cm (2.4 in) depth.

11.5 What type of structure should the SurfaceVue 10 be mounted to?

The SurfaceVue 10 is typically mounted to a large vertical pole or lattice tower. The sensor includes mounting brackets and band straps to be mounted to an 8 to 18 cm (3 to 7 inch) pole. For lattice tower mounting options please consult with Campbell Scientific.

11.6 Does the SurfaceVue 10 need to be continuously powered?

Yes, the SurfaceVue 10 needs continuous power to effectively measure the surface state, friction value, modeled wind, and modeled ground temperature.

Limited warranty

Covered equipment is warranted/guaranteed against defects in materials and workmanship under normal use and service for the period listed on your sales invoice or the product order information web page. The covered period begins on the date of shipment unless otherwise specified. For a repair to be covered under warranty, the following criteria must be met:

1. There must be a defect in materials or workmanship that affects form, fit, or function of the device.
2. The defect cannot be the result of misuse.
3. The defect must have occurred within a specified period of time; and
4. The determination must be made by a qualified technician at a Campbell Scientific Service Center/ repair facility.

The following is not covered:

1. Equipment which has been modified or altered in any way without the written permission of Campbell Scientific.
2. Batteries; and
3. Any equipment which has been subjected to misuse, neglect, acts of God or damage in transit.

Campbell Scientific regional offices handle repairs for customers within their territories. Please see the back page of the manual for a list of [regional offices](#) or visit www.campbellsci.com/contact  to determine which Campbell Scientific office serves your country. For directions on how to return equipment, see [Assistance](#).

Other manufacturer's products, that are resold by Campbell Scientific, are warranted only to the limits extended by the original manufacturer.

CAMPBELL SCIENTIFIC EXPRESSLY DISCLAIMS AND EXCLUDES ANY IMPLIED WARRANTIES OF MERCHANTABILITY OR FITNESS FOR A PARTICULAR PURPOSE. Campbell Scientific hereby disclaims, to the fullest extent allowed by applicable law, any and all warranties and conditions with respect to the products, whether express, implied, or statutory, other than those expressly provided herein.

Campbell Scientific will, as a default, return warranted equipment by surface carrier prepaid. However, the method of return shipment is at Campbell Scientific's sole discretion. Campbell Scientific will not reimburse the claimant for costs incurred in removing and/or reinstalling equipment. This warranty and the Company's obligation thereunder is in lieu of all other

warranties, expressed or implied, including those of suitability and fitness for a particular purpose. Campbell Scientific is not liable for consequential damage.

In the event of any conflict or inconsistency between the provisions of this Warranty and the provisions of Campbell Scientific's Terms, the provisions of Campbell Scientific's Terms shall prevail. Furthermore, Campbell Scientific's Terms are hereby incorporated by reference into this Warranty. To view Terms and conditions that apply to Campbell Scientific, Logan, UT, USA, see [Terms and Conditions](#). To view terms and conditions that apply to Campbell Scientific offices outside of the United States, contact the [regional office](#) that serves your country.

Assistance

Products may not be returned without prior authorization. Please inform us before returning equipment and obtain a **return material authorization (RMA) number** whether the repair is under warranty/guarantee or not. See [Limited warranty](#) for information on covered equipment.

Campbell Scientific regional offices handle repairs for customers within their territories. Please see the back page of the manual for a list of [regional offices](#) or visit www.campbellsci.com/contact  to determine which Campbell Scientific office serves your country.

When returning equipment, a RMA number must be clearly marked on the outside of the package. Please state the faults as clearly as possible. Quotations for repairs can be given on request.

It is the policy of Campbell Scientific to protect the health of its employees and provide a safe working environment. In support of this policy, when equipment is returned to Campbell Scientific, Logan, UT, USA, it is mandatory that a "[Declaration of Hazardous Material and Decontamination](#)" form be received before the return can be processed. If the form is not received within 5 working days of product receipt or is incomplete, the product will be returned to the customer at the customer's expense. For details on decontamination standards specific to your country, please reach out to your [regional Campbell Scientific](#) office.

NOTE:

All goods that cross trade boundaries may be subject to some form of fee (customs clearance, duties or import tax). Also, some regional offices require a purchase order upfront if a product is out of the warranty period. Please contact your [regional Campbell Scientific](#) office for details.

Safety

DANGER — MANY HAZARDS ARE ASSOCIATED WITH INSTALLING, USING, MAINTAINING, AND WORKING ON OR AROUND TRIPODS, TOWERS, AND ANY ATTACHMENTS TO TRIPODS AND TOWERS SUCH AS SENSORS, CROSSARMS, ENCLOSURES, ANTENNAS, ETC. FAILURE TO PROPERLY AND COMPLETELY ASSEMBLE, INSTALL, OPERATE, USE, AND MAINTAIN TRIPODS, TOWERS, AND ATTACHMENTS, AND FAILURE TO HEED WARNINGS, INCREASES THE RISK OF DEATH, ACCIDENT, SERIOUS INJURY, PROPERTY DAMAGE, AND PRODUCT FAILURE. TAKE ALL REASONABLE PRECAUTIONS TO AVOID THESE HAZARDS. CHECK WITH YOUR ORGANIZATION'S SAFETY COORDINATOR (OR POLICY) FOR PROCEDURES AND REQUIRED PROTECTIVE EQUIPMENT PRIOR TO PERFORMING ANY WORK.

Use tripods, towers, and attachments to tripods and towers only for purposes for which they are designed. Do not exceed design limits. Be familiar and comply with all instructions provided in product manuals. Manuals are available at www.campbellsci.com You are responsible for conformance with governing codes and regulations, including safety regulations, and the integrity and location of structures or land to which towers, tripods, and any attachments are attached. Installation sites should be evaluated and approved by a qualified engineer. If questions or concerns arise regarding installation, use, or maintenance of tripods, towers, attachments, or electrical connections, consult with a licensed and qualified engineer or electrician.

General

- Protect from over-voltage.
- Protect electrical equipment from water.
- Protect from electrostatic discharge (ESD).
- Protect from lightning.
- Prior to performing site or installation work, obtain required approvals and permits. Comply with all governing structure-height regulations, such as those of the FAA in the USA.
- Use only qualified personnel for installation, use, and maintenance of tripods and towers, and any attachments to tripods and towers. The use of licensed and qualified contractors is highly recommended.
- Read all applicable instructions carefully and understand procedures thoroughly before beginning work.
- Wear a hardhat and eye protection, and take other appropriate safety precautions while working on or around tripods and towers.
- Do not climb tripods or towers at any time, and prohibit climbing by other persons. Take reasonable precautions to secure tripod and tower sites from trespassers.
- Use only manufacturer recommended parts, materials, and tools.

Utility and Electrical

- You can be killed or sustain serious bodily injury if the tripod, tower, or attachments you are installing, constructing, using, or maintaining, or a tool, stake, or anchor, come in contact with overhead or underground utility lines.
- Maintain a distance of at least one-and-one-half times structure height, 6 meters (20 feet), or the distance required by applicable law, whichever is greater, between overhead utility lines and the structure (tripod, tower, attachments, or tools).
- Prior to performing site or installation work, inform all utility companies and have all underground utilities marked.
- Comply with all electrical codes. Electrical equipment and related grounding devices should be installed by a licensed and qualified electrician.
- Only use power sources approved for use in the country of installation to power Campbell Scientific devices.

Elevated Work and Weather

- Exercise extreme caution when performing elevated work.
- Use appropriate equipment and safety practices.
- During installation and maintenance, keep tower and tripod sites clear of un-trained or non-essential personnel. Take precautions to prevent elevated tools and objects from dropping.
- Do not perform any work in inclement weather, including wind, rain, snow, lightning, etc.

Internal Battery

- Be aware of fire, explosion, and severe-burn hazards.
- Misuse or improper installation of the internal lithium battery can cause severe injury.

- Do not recharge, disassemble, heat above 100 °C (212 °F), solder directly to the cell, incinerate, or expose contents to water. Dispose of spent batteries properly.

Use and disposal of batteries

- Where batteries need to be transported to the installation site, ensure they are packed to prevent the battery terminals shorting which could cause a fire or explosion. Especially in the case of lithium batteries, ensure they are packed and transported in a way that complies with local shipping regulations and the safety requirements of the carriers involved.
- When installing the batteries follow the installation instructions very carefully. This is to avoid risk of damage to the equipment caused by installing the wrong type of battery or reverse connections.
- When disposing of used batteries, it is still important to avoid the risk of shorting. Do not dispose of the batteries in a fire as there is risk of explosion and leakage of harmful chemicals into the environment. Batteries should be disposed of at registered recycling facilities.

Avoiding unnecessary exposure to radio transmitter radiation

- Where the equipment includes a radio transmitter, precautions should be taken to avoid unnecessary exposure to radiation from the antenna. The degree of caution required varies with the power of the transmitter, but as a rule it is best to avoid getting closer to the antenna than 20 cm (8 inches) when the antenna is active. In particular keep your head away from the antenna. For higher power radios (in excess of 1 W ERP) turn the radio off when servicing the system, unless the antenna is installed away from the station, e.g. it is mounted above the system on an arm or pole.

Maintenance

- Periodically (at least yearly) check for wear and damage, including corrosion, stress cracks, frayed cables, loose cable clamps, cable tightness, etc. and take necessary corrective actions.
- Periodically (at least yearly) check electrical ground connections.

WHILE EVERY ATTEMPT IS MADE TO EMBODY THE HIGHEST DEGREE OF SAFETY IN ALL CAMPBELL SCIENTIFIC PRODUCTS, THE CUSTOMER ASSUMES ALL RISK FROM ANY INJURY RESULTING FROM IMPROPER INSTALLATION, USE, OR MAINTENANCE OF TRIPODS, TOWERS, OR ATTACHMENTS TO TRIPODS AND TOWERS SUCH AS SENSORS, CROSSARMS, ENCLOSURES, ANTENNAS, ETC.

Global Sales and Support Network

A worldwide network to help meet your needs



Campbell Scientific Regional Offices

Australia

Location: Garbutt, QLD Australia
Phone: 61.7.4401.7700
Email: info@campbellsci.com.au
Website: www.campbellsci.com.au

Brazil

Location: São Paulo, SP Brazil
Phone: 11.3732.3399
Email: vendas@campbellsci.com.br
Website: www.campbellsci.com.br

Canada

Location: Edmonton, AB Canada
Phone: 780.454.2505
Email: dataloggers@campbellsci.ca
Website: www.campbellsci.ca

China

Location: Beijing, P. R. China
Phone: 86.10.6561.0080
Email: info@campbellsci.com.cn
Website: www.campbellsci.com.cn

Costa Rica

Location: San Pedro, Costa Rica
Phone: 506.2280.1564
Email: info@campbellsci.com
Website: www.campbellsci.com

France

Location: Montrouge, France
Phone: 0033.0.1.56.45.15.20
Email: info@campbellsci.fr
Website: www.campbellsci.fr

Germany

Location: Bremen, Germany
Phone: 49.0.421.460974.0
Email: info@campbellsci.de
Website: www.campbellsci.de

India

Location: New Delhi, DL India
Phone: 91.11.46500481.482
Email: info@campbellsci.in
Website: www.campbellsci.in

Japan

Location: Kawagishi, Toda City, Japan
Phone: 048.400.5001
Email: jp-info@campbellsci.com
Website: www.campbellsci.co.jp

South Africa

Location: Stellenbosch, South Africa
Phone: 27.21.8809960
Email: sales@campbellsci.co.za
Website: www.campbellsci.co.za

Spain

Location: Barcelona, Spain
Phone: 34.93.2323938
Email: info@campbellsci.es
Website: www.campbellsci.es

Thailand

Location: Bangkok, Thailand
Phone: 66.2.719.3399
Email: info@campbellsci.asia
Website: www.campbellsci.asia

UK

Location: Shephed, Loughborough, UK
Phone: 44.0.1509.601141
Email: sales@campbellsci.co.uk
Website: www.campbellsci.co.uk

USA

Location: Logan, UT USA
Phone: 435.227.9120
Email: info@campbellsci.com
Website: www.campbellsci.com