



SunScout

Solar Resource Assessment Station



Table of contents

1. Introduction	1
2. Siting	2
3. Installation	2
3.1 Tripod	2
3.2 Guy wire assembly	4
3.3 Rain gage	6
3.4 North/South crossarm, MetSENS500, and antenna	8
3.5 Crossarm brace	10
3.6 East/West crossarm and irradiance sensors	11
3.7 Soiling assembly	13
3.8 Enclosure	14
3.9 Power supply solar panel	15
3.9.1 Solar panel angle	20
3.10 Level sensors	20
3.11 Optional albedo	21
4. Field wiring	23
4.1 Digital sensor connections	24
4.2 Analog sensor wiring	26
4.3 Power connections	28
5. Operation	30

1. Introduction

This document shows the basic steps required to install the SunScout. More detailed installation information is provided in the CM106B, solar panel, and sensor manuals. The main tripod assembly is installed in following order:

1. Tripod
2. Guy wire assembly
3. Tipping bucket
4. North/South crossarm, MetSENS500, antenna, and guyed crossarm brace
5. East/West crossarm, irradiance sensors, and crossarm brace
6. Soiling assembly
7. Enclosure
8. Power supply solar panel

If the optional albedo sensor is used, it will be mounted on a separate tripod and crossarm.

Tools list:

- Compass
- Ladder (recommended)
- High-lift jack
- Tape Measure
- Socket wrench set 13 mm (1/2 in), 24 mm (5/16 in), and 11 mm (7/16 in) deep sockets

NOTE:

A second set of wrenches is useful for components that have nuts and bolts combinations.



- Hex key set (US and Metric)
- Screwdrivers large and small, Phillips and straight
- Wire strippers, wire cutters, etc.
- Large hammer
- Duckbill anchor driver
- Zipties

2. Siting

Locate the SunScout away from obstructions such as trees and buildings. The horizontal distance from an obstruction should be at least ten times the height of the obstruction. No obstacles should be between the course of the sun and the pyranometers. The SunScout should also be mounted away from electrical equipment that generate magnetic fields, which will affect the electronic compass of the MetSENS500.

3. Installation

3.1 Tripod

The following procedure is for mounting on level ground; refer to the CM106B manual (available at www.campbellsci.com/cm106b ) for mounting on unlevel ground. For a video demonstrating how to assemble a tripod, see www.campbellsci.com/videos/tripod .

1. Select appropriate location for center of tripod.
2. Layout North/South line through center point of tripod (placement of duckbill anchor).
3. Drive duckbill into ground until only a small loop of wire is exposed.

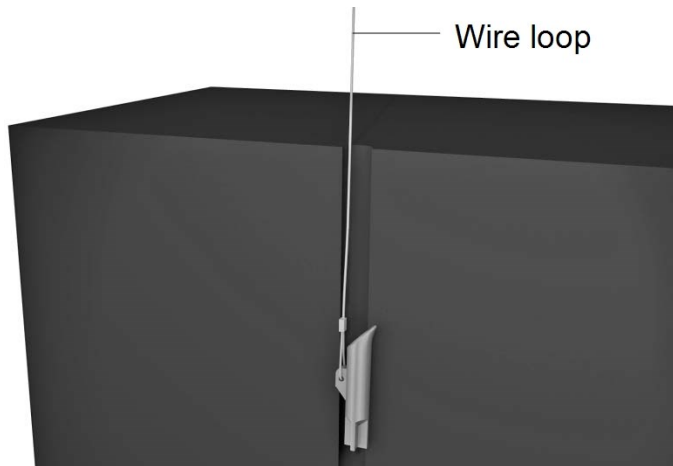

4. Attach a high-lift jack to the loop and jack the anchor up about 6 inches to rotate the anchor into the load-lock position.



5. No mast extension needed unless additional height is needed for specific site.
6. Tripod base should be approximately 30 cm (12 in) off the ground (if desired a 30 cm [12 in] block can be used to support tripod base during install for support and to ensure appropriate base height).
7. Loosen clamping bolt to drop and adjust tripod legs.

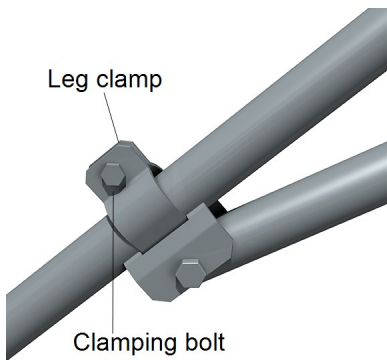

8. Align one tripod leg NORTH from center point along the established North/South line.
9. Loosen the base bolts and insert mast.

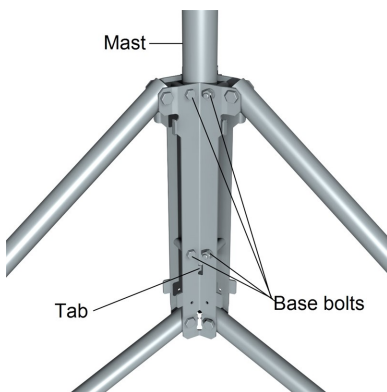

10. Set leg clamps approximately 53 cm (21 in) from the tripod foot.

11. Install center mast and level tripod base vertically then tighten clamp bolts.
12. Hook S-hook of center duckbill anchor turnbuckle to tripod base bolt.
13. Tighten the turnbuckle until the tripod is firmly secured to the anchor.

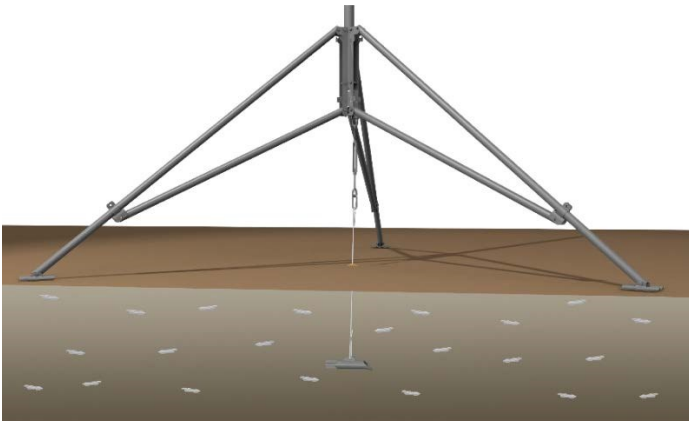

14. Install spikes in feet of tripod.

3.2 Guy wire assembly

1. Bolt the guy bracket onto mast using the bolt hole that is 23 cm (9 in) down the mast.
2. Attach the three guy wires to the guy collar and slide the collar over the mast so that the collar butts against the bracket.

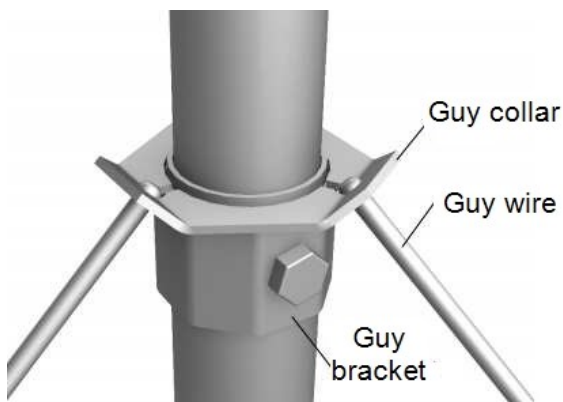

3. Unscrew the turnbuckles so that only 13 mm (0.5 in) of thread extends beyond the inside of the turnbuckle body.
4. Attach the S-hook of turnbuckle to the tripod leg.

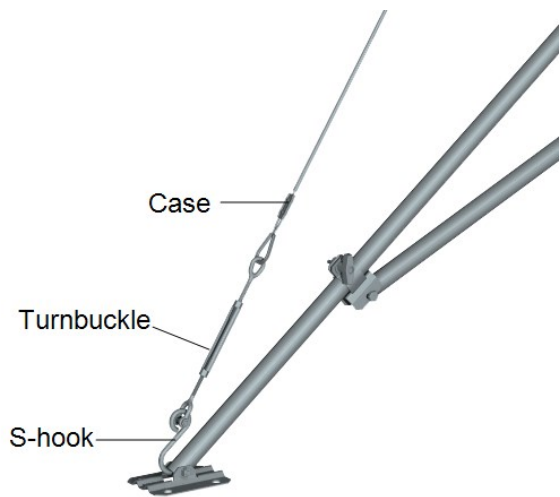

5. Loosen the two clamp nuts, and remove the slack in the guy line by feeding the load end of the guy wire through the case while pulling up on the free end.

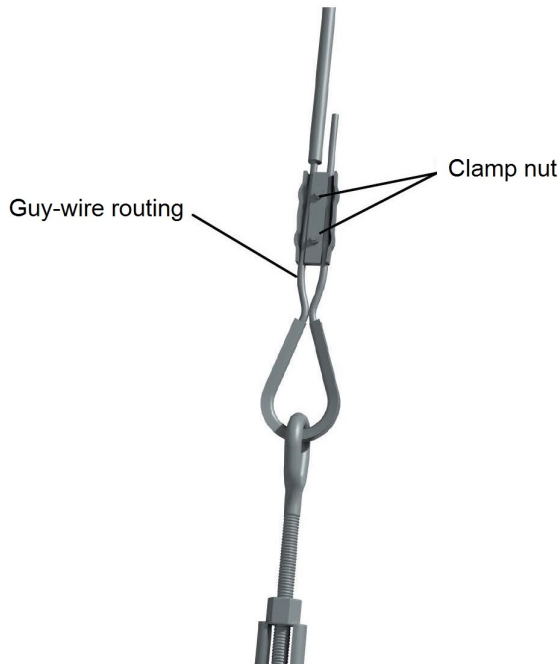

6. After the slack has been removed from the guy lines, tighten the clamp nuts to 3.5 N-m (31 in-lb), and then tighten the turnbuckles to 68 to 91 kg (150 lb to 200 lb) tension.

NOTE:

During site visits, check that the guy-wire clamp nuts are still at 3.5 N-m (31 in-lb), and that guy wire tension is still 68 to 91 kg (150 lb to 200 lb).

7. Coil and secure the excess guy wires.

3.3 Rain gage

The SunScout is shipped with a CM270 mounting bracket for attaching the sensor to the mast.

1. Loosen the thumbscrews holding the funnel on the bucket and then take the funnel off the top of the bucket.
2. Remove the small rubber band securing the tipping bucket, which protects it during shipping.
3. Seat the funnel back onto the rain gage, and push the funnel all the way down until it is fully seated on the main body.
4. Hand tighten the thumb screws (if present) to secure the funnel to the body.

NOTE:

Press either end of the bucket down against its stop to make sure the bucket is NOT hung up in the center before hand tightening the thumb screws.

5. Mount the rain gage to the CM270 mount.
 - a. Turn the rain gage upside down and set it on a hard surface such as a table top.
 - b. Place the mounting bracket on the bottom of the bucket. Line up the three holes in the mounting bracket with the three holes used for the mounting feet. When positioned correctly, the tipping-bucket cable will be near the bubble level and pole-mounting hardware.

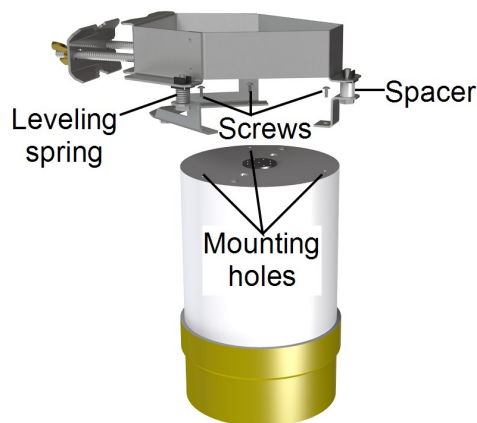

- c. Use three self-tapping screws and a long Phillips screwdriver to securely fasten the mounting bracket to the bottom of the tipping bucket.
- d. Turn the assembly over, and tighten the bolt that uses the cylindrical spacer. The

bolts securing the leveling springs need to remain loose to allow leveling when the bracket is mounted to the mast.

6. Remove the mast clamp, washers, and wing nuts.
7. Place the assembly over the mast at 8 cm (3 in) above the top of the guy collar. The rain gage should be facing North at about a 30 to 45 degree angle from the North line.

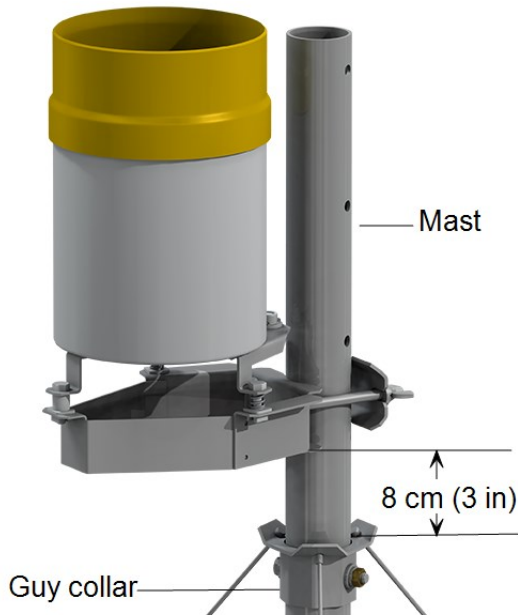

8. Secure the bracket to the mast with the mounting hardware. Put the mast clamp on first followed by the flat washers, lock washers, and wingnuts.

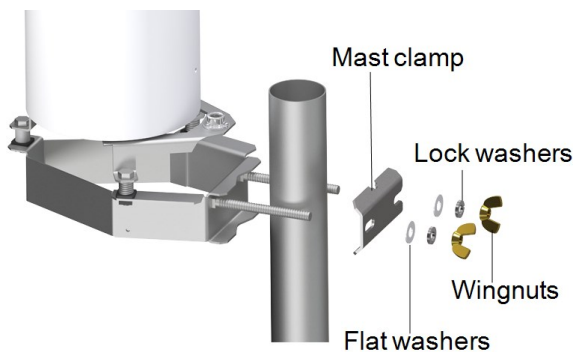

9. Tighten the assembly onto the pipe, while ensuring that nothing is blocking the top of the rain gage.

NOTE:

Sensors are leveled after all the equipment is installed because the installation process can alter leveling. See [Level sensors](#) (p. 20) for more information.

3.4 North/South crossarm, MetSENS500, and antenna

A MetSENS stand mount, antenna stand, 30 cm (12 in) pipe, and a Nu-Rail fitting are shipped with the SunScout for attaching the MetSENS500 and antenna to the CM204 crossarm.

1. Using the previously defined North/South line. Install the CM204 crossarm parallel to this line above the CM270 mount of the rain gage. The crossarm should stick out south about 25 cm (10 in) from mast.

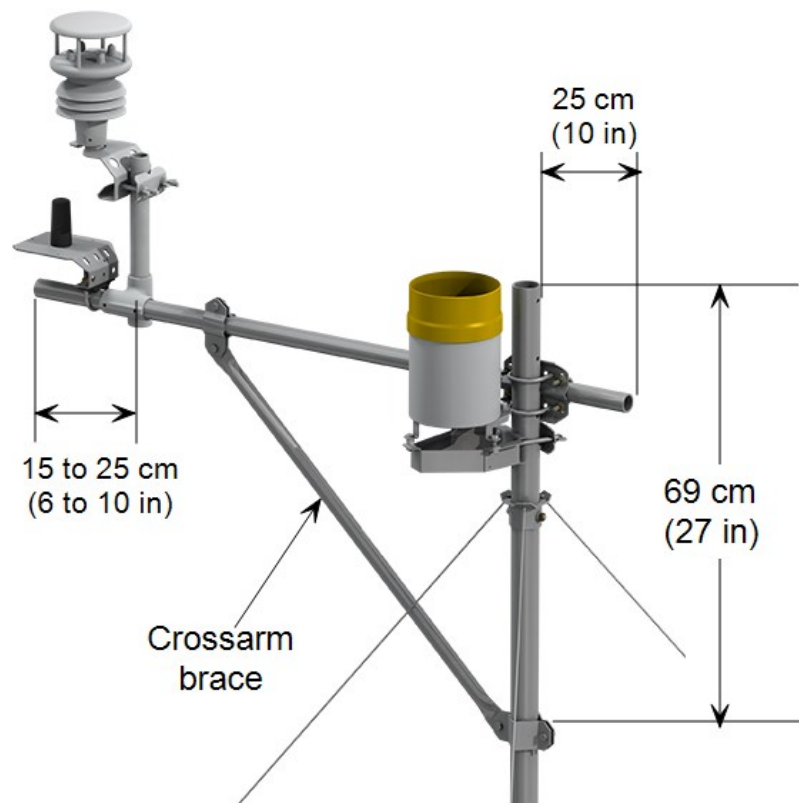

2. Install the [Crossarm brace](#) (p. 10). Affix the brace arm to the mast at approximately 69 cm (27 in) from top of the mast.
3. Attach the cable connector to the mating connector located on the bottom of the MetSENS500.
4. Use the Philips screws to secure the MetSENS500 to the MetSENS stand mount.
5. Secure the MetSENS stand mount to the 30 cm (12 in) pipe using the mounting hardware (mast clamp, carriage screws, flat washers, lock washers, and wingnuts).

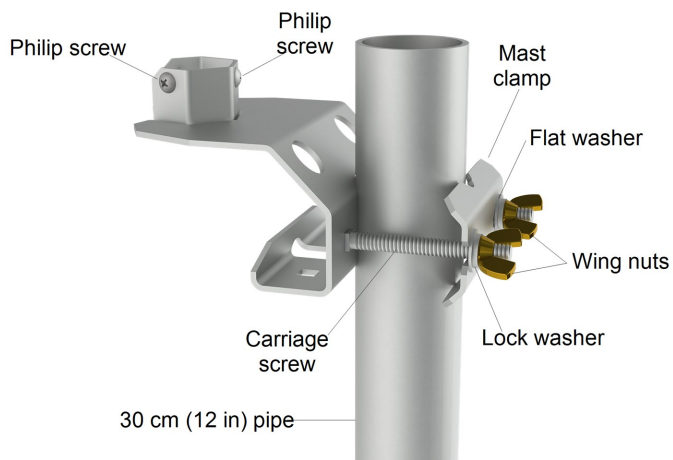

6. Fit the Nu-Rail fitting on the bottom of the pipe and secure with the setting screws.
7. Secure the Nu-Rail fitting to the crossarm.

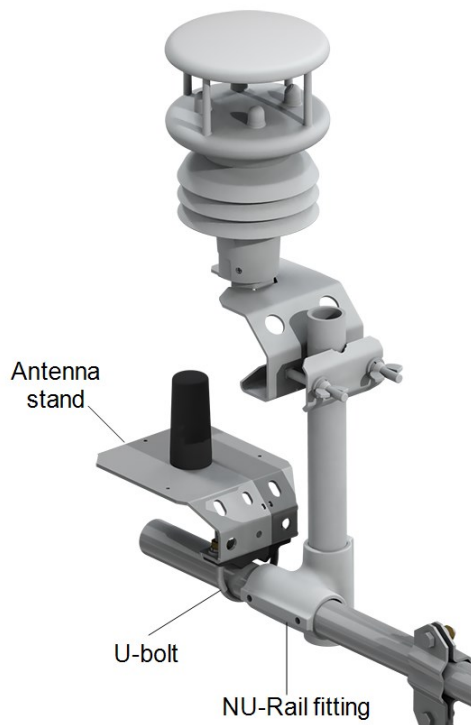

8. Ensure that the four notches on the sensor are aligned to the magnetic north. Refer to the following: www.geosats.com/magdecli.html or www.ngdc.noaa.gov/geomag/declination.shtml

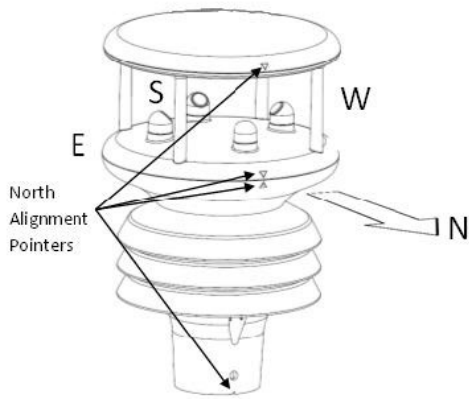

9. Mount the antenna to the antenna stand.
10. Use the U-bolt, washers and nuts, to secure the antenna stand to the end of the crossarm.

3.5 Crossarm brace

To provide additional stability, the North/South crossarm uses a guyed crossarm brace and the East/West crossarm and optional albedo crossarm use an unguyed crossarm brace.

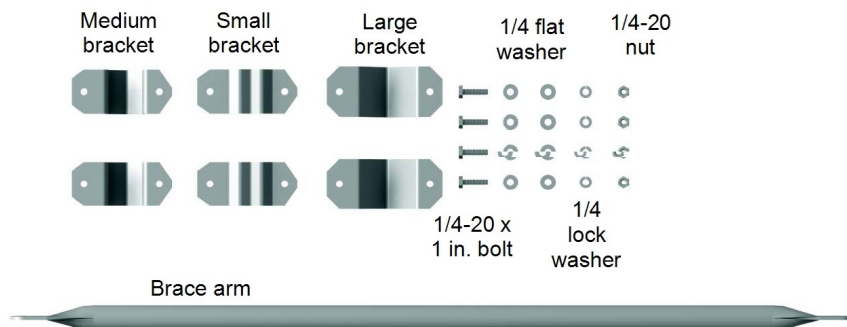
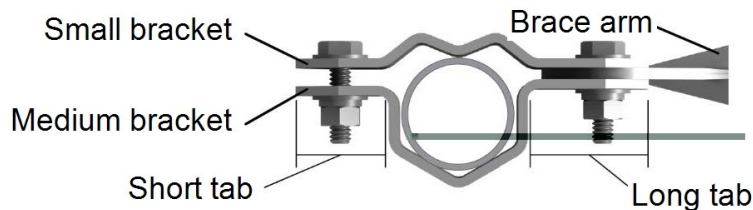

Figure 3-1. Crossarm brace components

1. Each bracket has a long tab and short tab where the bolts are attached. The brace arm must be attached to the end with the long tab.



2. For the North/South crossarm, insert guy wires into collars.

3. Attach one end of the brace arm to the tripod mast below the crossarm. Leave the bolts finger-tight.

NOTE:

For the North/South crossarm, affix the brace arm to the mast at approximately 69 cm (27 in) from top of the mast. Mount the crossarm brace for the East/West crossarm directly below the North/South crossarm brace.

4. Lift the free end of the brace arm to the crossarm and attach it to the crossarm. Only finger-tighten the bolts.
5. Adjust the position of the brace arm as needed.
6. Fully tighten the two bolts directly connected to the brace arm, and then tighten the remaining two bolts to clamp the brace arm to the crossarm and tower or tripod mast.
7. For the North/South crossarm, attach guy wires with S-hooks to tripod feet and tighten to desired tension.

3.6 East/West crossarm and irradiance sensors

CM256 mounting brackets, 30 cm (12 in) pipes, and Nu-Rail fittings are shipped with the SunScout for attaching the irradiance sensors to the crossarm.

1. Mount the East/West CM204 crossarm in the center of the mast and directly above the North/South Crossarm.

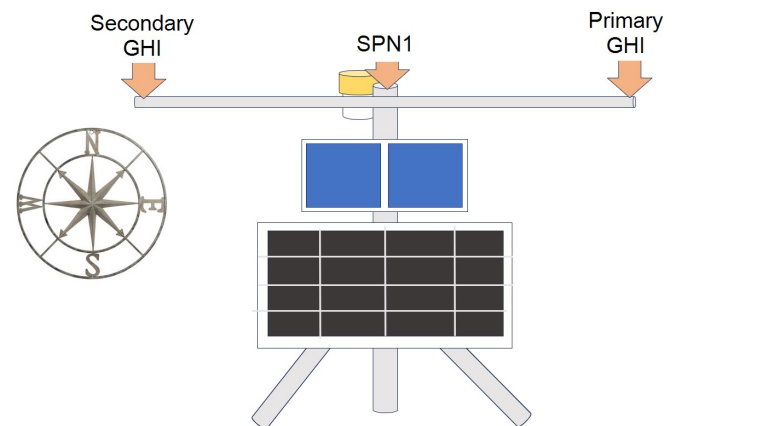

2. Install the [Crossarm brace](#) (p. 10).

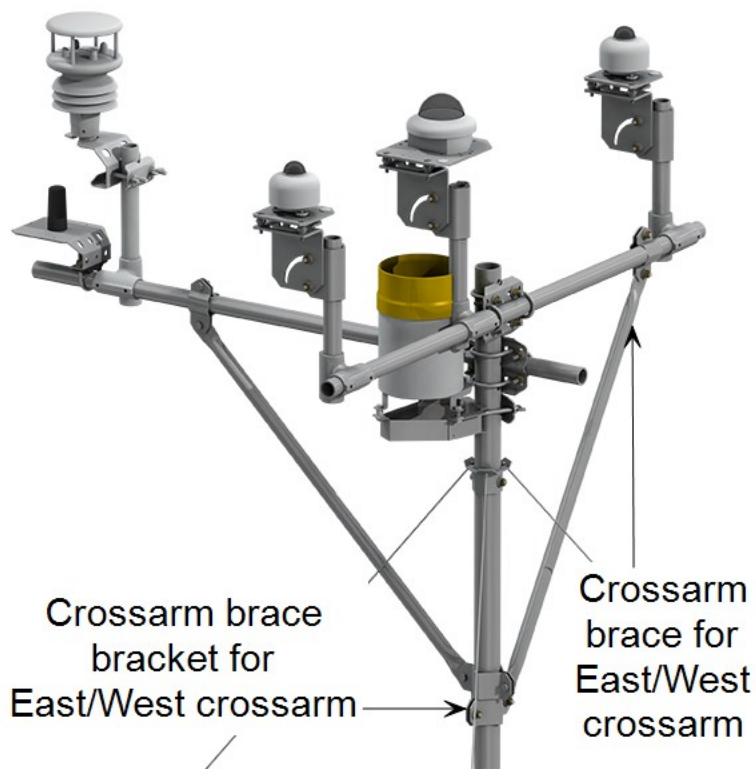

3. Fit a Nu-Rail fitting on the bottom of each 30 cm (12 in) pipe and secure with the setting screws.
4. Secure the Nu-Rail fittings to the crossarm.
5. Mount the CM256 mounting bracket to the pipes.
6. Secure each irradiance sensor to a CM256 mounting bracket.

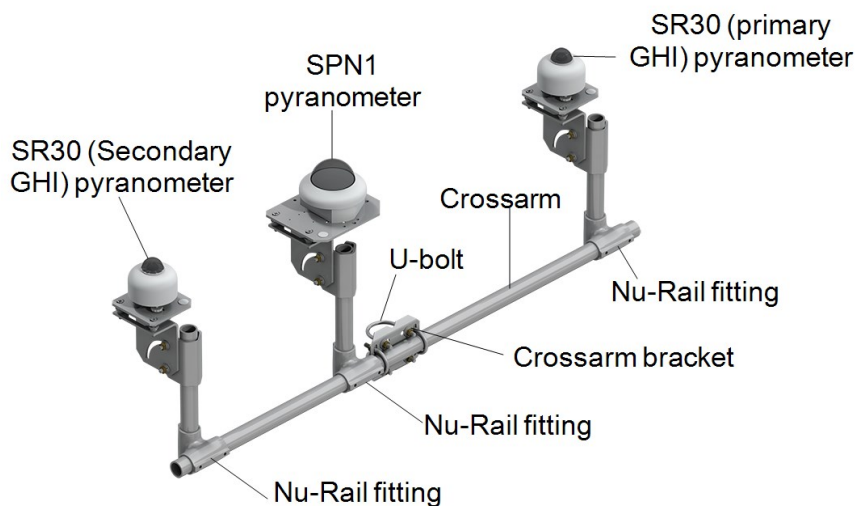

NOTE:

Sensors are leveled after all the equipment is installed because the installation process can alter leveling. See [Level sensors](#) (p. 20) for more information.

3.7 Soiling assembly

The soiling assembly consists of two solar panels attached to a Nu-Rail fitting with CS241DM temperature sensors attached to the back of each solar panel.

1. Install soiling kit assembly by sliding the Nu-Rail onto the South end of North/South crossarm as shown in the following image.

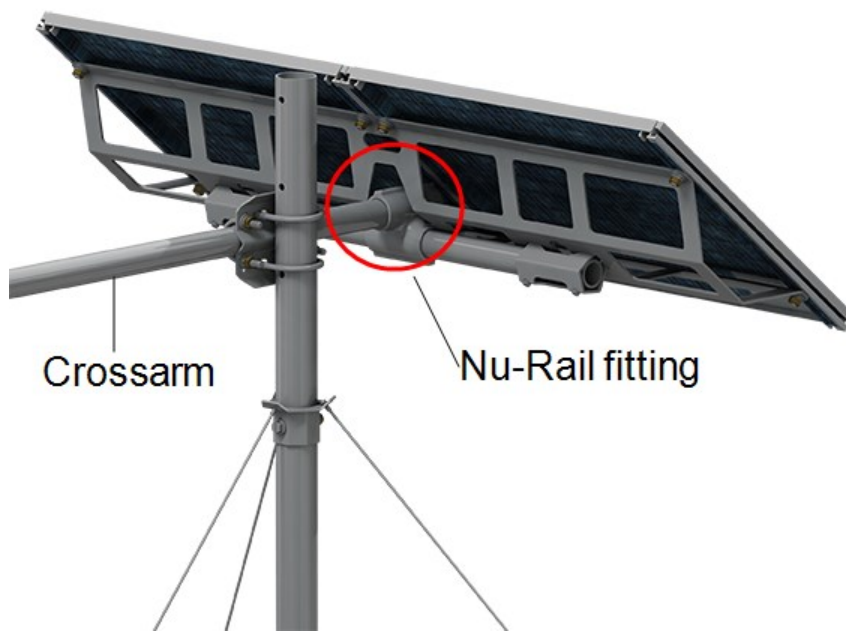

2. Level panels and tighten the Nu-Rail to the crossarm.
3. Tilt panels to match site latitude and tighten set screws.

3.8 Enclosure

1. Attach the bracket for the upper enclosure hook assembly 86 cm (34 in) below the top of the tripod mast. The bracket should be installed with the hook side up, and facing north to northwest to allow door to open.



2. Tighten the clamp so that it doesn't move.
3. Hang the enclosure on the hook bracket.
4. Affix the bottom of enclosure using the U-bolt washers, and wing nuts.
5. Route the sensors and antenna cables down the crossarms, braces, and mast to the enclosure.
6. Connect the cable wires to the terminal buses inside the enclosure (see [Field wiring](#) [p. 23]).
7. Secure the cables to the crossarms, braces, and mast using cable ties.

3.9 Power supply solar panel

Keep the solar panel covered during assembly to prevent power output during the assembly process.

1. Attach one mount bracket to the mast approximately 40 cm (16 in) above the tripod legs using two U-bolts, flat washers, lock washers, and nuts. Orient the mount bracket to face the equator.

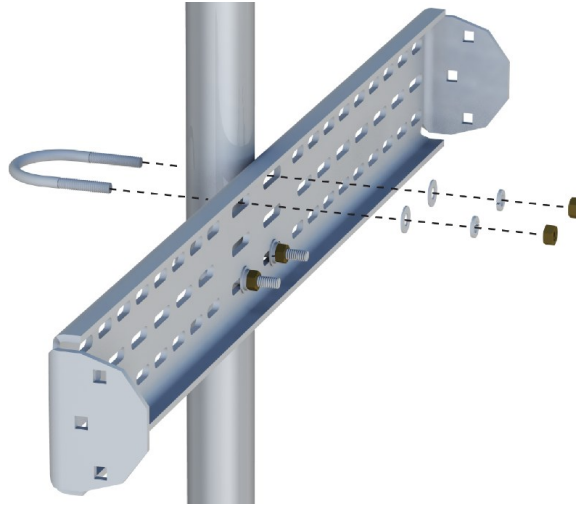

Figure 3-2. Attaching the upper mount bracket

2. Attach a mount arm to the top hole on either side of the mount bracket using a bolt, flat washer, lock washer, and nut. Do not fully tighten either nut.

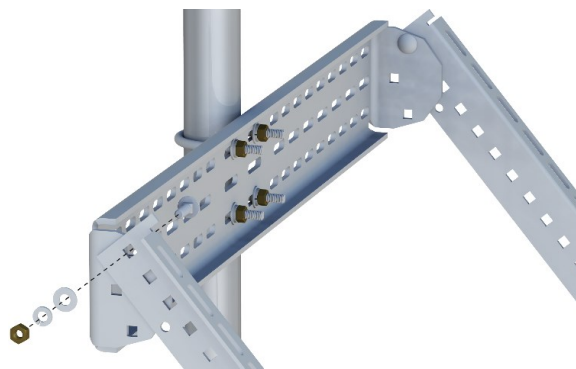

Figure 3-3. Attaching the mount arms

3. Place two support struts together, overlapping the large slot in each strut. Use two bolts, flat washers, lock washers, and nuts to attach the struts to each other. Do not fully tighten the nuts. Repeat for the remaining two support struts.



Figure 3-4. Assembling the support struts

4. Connect the end of a support strut assembly to the sixth hole from the bottom on one of the mount arms using a bolt, flat washer, lock washer, and nut. Connect the second support strut assembly to the sixth hole on the second mount arm. Do not fully tighten these nuts. The support struts may be moved to a different hole position when adjusting the mount angle in step 6.



Figure 3-5. Attaching the support struts to the mount arms

5. Place the second mount bracket on the ground between the two strut assemblies. Attach each strut assembly to the mount bracket in the hole shown with a bolt, flat washer, lock washer, and nut.

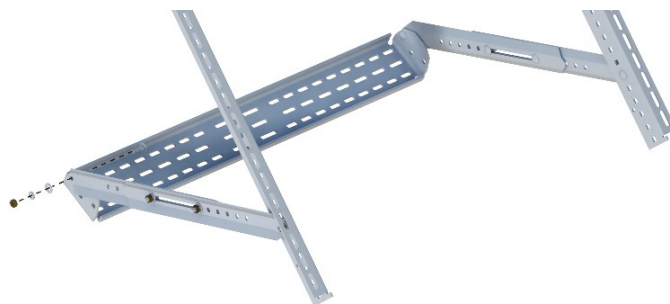

Figure 3-6. Attaching the lower mount bracket

6. Place the lower mount bracket on the lower supports of the two closest tripod legs. Center the mount bracket evenly between the two legs. Secure the mount bracket in place with two U-bolts, flat washers, lock washers, and nuts. It may be necessary to rotate the U-bolt so the ends of the bolt pass through holes on different rows in the lower mount bracket.
7. Determine the correct mounting angle for the location. Adjust the support strut length (blue arrows in [Figure 3-7](#) [p. 17]) or change the mounting location of the support struts on the mount arms (yellow arrows in [Figure 3-7](#) [p. 17]) to set the mount to the proper angle. Refer to [Solar panel angle](#) (p. 20) for correct angles and mount adjustments.



Figure 3-7. Adjusting the mount angle

8. Attach the carabiner at the free end of one of the guy ropes to the hole shown on the lower end of the mount arm (A). Attach the second carabiner on the same guy rope to the opposite side of the lower mount bracket in the hole indicated (B). Repeat with the carabiners on the second guy rope, but on opposite sides of the mount, to form an 'X' with the two guy ropes (C).

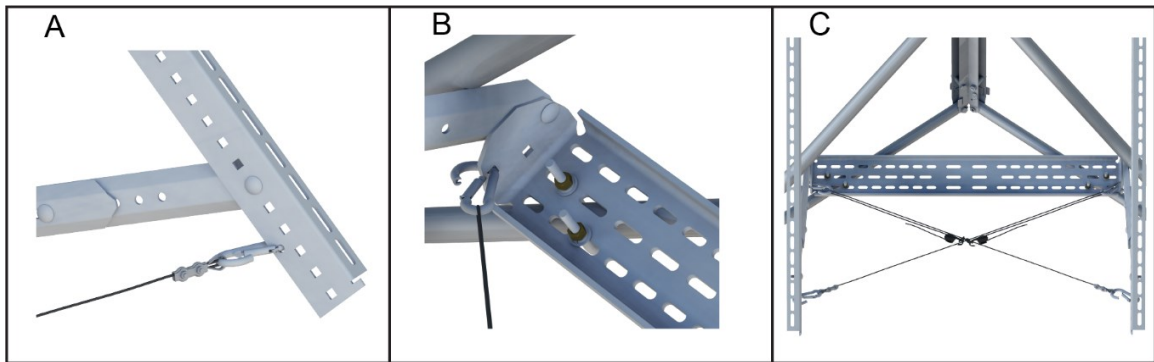

Figure 3-8. Attaching the guy ropes

CAUTION:

Do not tighten ropes yet.

9. Install tabs at the bottom of the solar panel mount.

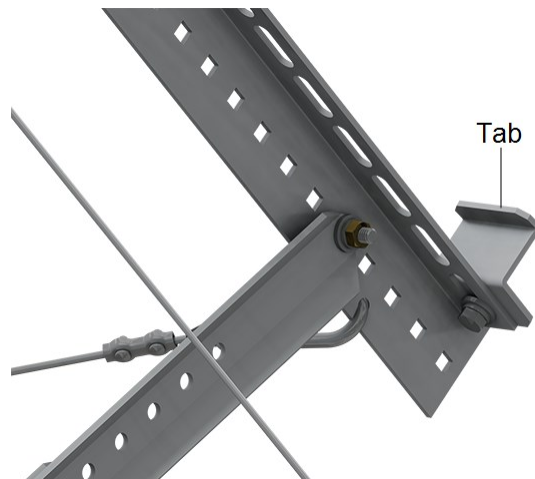

Figure 3-9. Solar panel tabs

10. Determine which edge of the solar panel will be the top. Gently set the solar panel onto the mount. Let the solar panel rest on the tabs at the end of each mount arm.

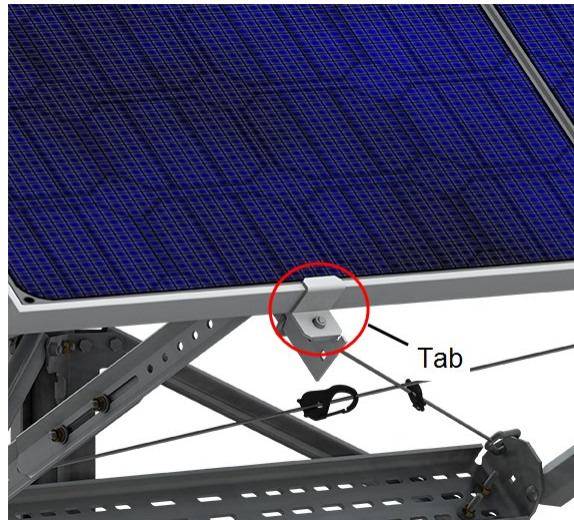

Figure 3-10. Installing the solar panel

11. Install tabs at the top of the solar panel mounts and secure the solar panel to the mount using the tabs.



Figure 3-11. Installed solar panel

- Connect the solar panel to the solar panel inputs (see [Power connections](#) [p. 28]) and uncover the solar panel.

3.9.1 Solar panel angle

The solar panel should be oriented to receive maximum insolation (incident solar radiation) over the course of a year. [Table 3-1](#) (p. 20) suggests optimal angles for the solar panel through a range of latitudes.

Site latitude (N or S)	Tilt angle
0° - 10°	10°
11° - 20°	Latitude +5°
21° - 45°	Latitude +10°
46° - 65°	Latitude +15°
> 65°	80°

¹From *Design Aids for Small PV Power Systems*, Solorex Corp.

3.10 Level sensors

The sensors are leveled after mounting all the equipment because equipment installation can affect leveling.

- For the rain gage, adjust the bolts on the leveling springs until the bubble in the level is inside the bullseye.

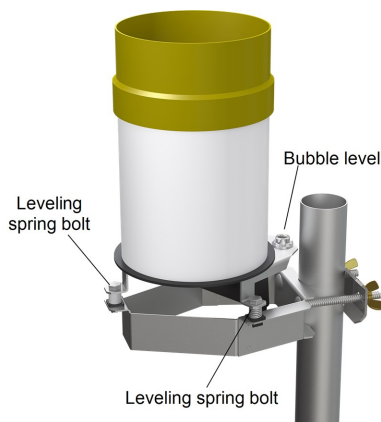

2. Use the sensor bubble level to level each irradiance sensor using the adjustment screws of the CM256 mount.

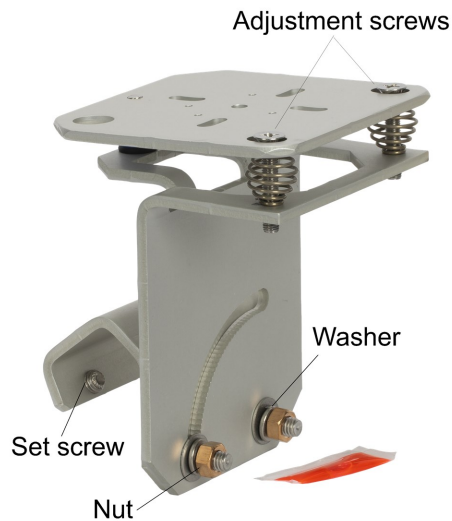

3. Verify CM256 mounting hardware is firmly tightened, and that the mounting bracket is at the desired angle.

3.11 Optional albedo

Albedo measurements are made by using two pyranometers (SR30 or SR05), one facing upward and one facing downward. In the SunScout system, the pyranometers are mounted together on a bracket that can be easily secured to a crossarm.

Locate the optional albedo tripod away from the main tripod and obstructions such as trees and buildings. The horizontal distance from the main tripod and obstructions should be at least ten times the height of the tripod or obstruction. No obstacles should be between the course of the sun and the pyranometers. Mount the sensor at least 1.5 m (5 ft) above the soil surface.



1. Install the [Tripod](#) (p. 2).
2. Install the [Guy wire assembly](#) (p. 4)
3. Install the CM204 crossarm along the North/South line 23 to 25 cm (9 to 10 in) extending south from the mast of the tripod. Mount the crossarm at a height that will place the sensor between 1.5 to 2 m (5 to 6.5 ft) above the soil surface. This reduces the effect of shadows.
4. Install the [Crossarm brace](#) (p. 10).
5. Slide the albedo sensor on the end of the crossarm and secure it to the crossarm using the mounting hardware.

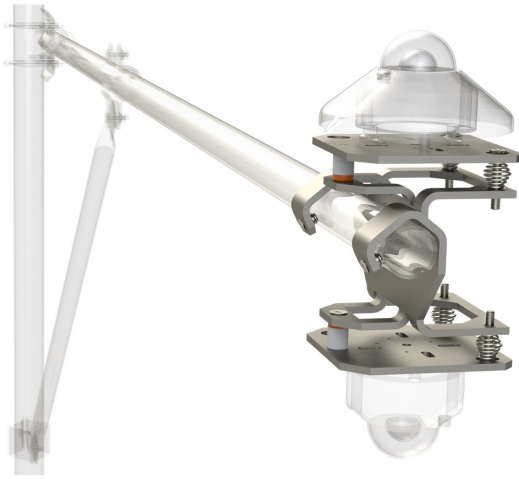

6. Route the cables down the crossarm and tripod to the enclosure.
7. Connect the cable wires to the terminal buses inside the enclosure (see [Table 4-2](#) [p. 25]).
8. Secure the cables to the crossarm and tripod by using cable ties.

4. Field wiring

The following sections provide wiring diagrams and tables for the sensors and the power supply. A schematic on the inside lid of the enclosure also shows the field connections. [Figure 4-1](#) (p. 23) shows the sensor and power wiring into the terminal buses.

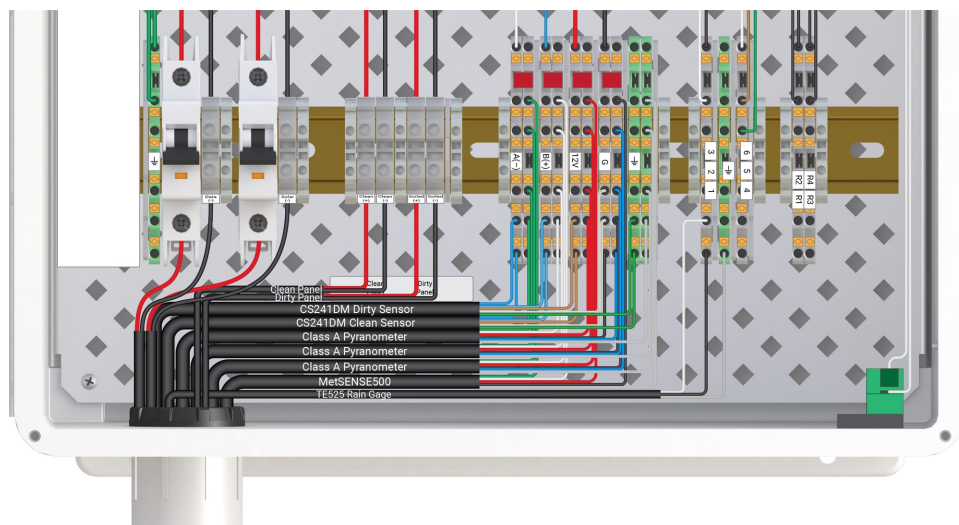

Figure 4-1. SunScout terminal buses

4.1 Digital sensor connections

These digital sensors can connect to any of the terminals in an appropriate terminal block.

Figure 4-2 (p. 24) and Table 4-1 (p. 24) provide wiring information for the MetSENS500. Figure 4-3 (p. 25) and Table 4-2 (p. 25) provide wiring information for the pyranometers and optional albedo. Figure 4-4 (p. 26) and Table 4-3 (p. 26) provide the wiring information for the CS241DM sensors.

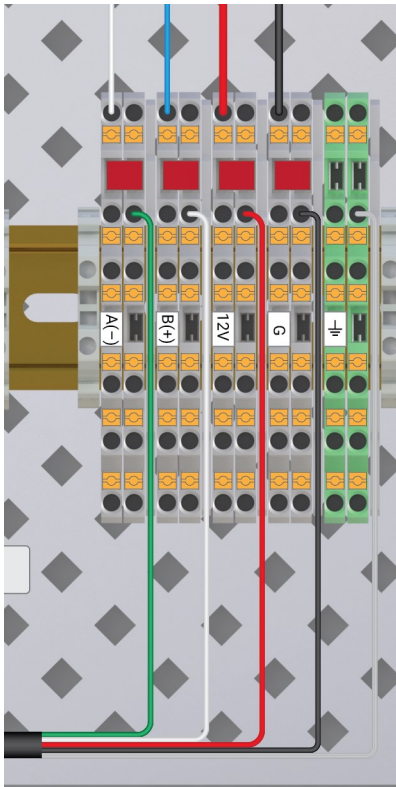

Figure 4-2. MetSENS500 wiring

Table 4-1: MetSENS500 compact weather station connections		
Wire color	Function	Terminal block label
Green	RS-485 A(-)	A-
White	RS-485 A(B+)	B+
Red	Power in (12V)	12V
Black	Power ground	G
Clear	Shield	⏏

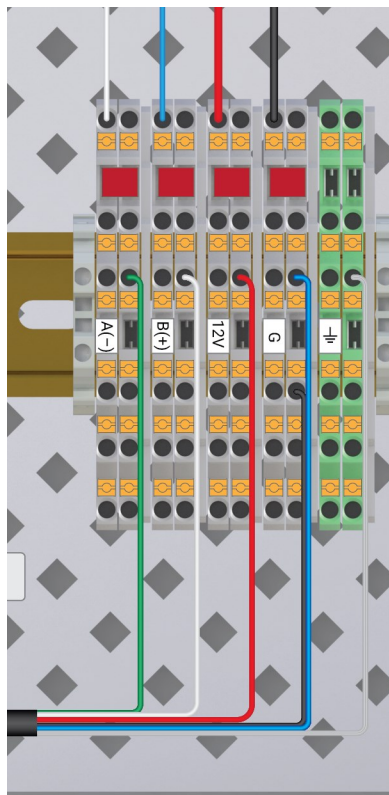

Figure 4-3. Pyranometers and albedo (up and down) connections

Table 4-2: Class A pyranometers and albedo (up and down) connections		
Wire color	Function	Terminal block label
Green	RS-485 A(-)	A-
White	RS-485 A(B+)	B+
Red	Power in (12V)	12V
Black	Power ground	G
Blue	Power ground	G
Clear	Shield	⏏

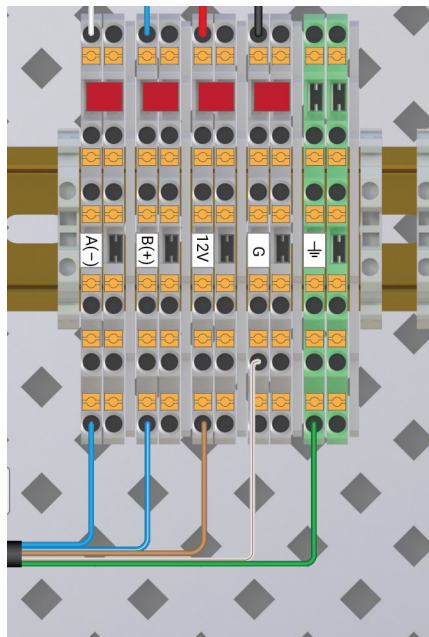

Figure 4-4. CS241DM connections

Table 4-3: CS241DM (clean and soiled) connections		
Wire color	Function	Terminal block label
Blue	RS-485 A(-)	A-
Blue/white	RS-485 A(B+)	B+
Brown	Power in (12V)	12V
White /brown	Power ground	G
Clear	Shield	⏚

4.2 Analog sensor wiring

Figure 4-5 (p. 27) and Table 4-4 (p. 27) provide wiring information for the TE525 tipping bucket rain gage. Table 4-5 (p. 27) provides wiring information for the optional SPN1 sunshine pyranometer. Figure 4-6 (p. 28), Table 4-6 (p. 28), and Table 4-7 (p. 28) provide wiring information for the clean and soiled solar panels.

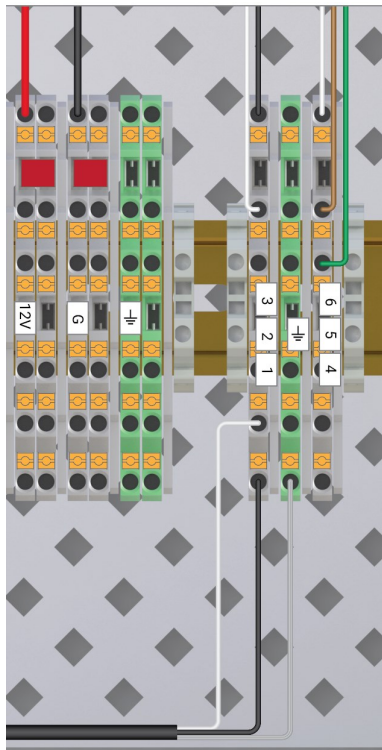

Figure 4-5. Rain gage connections

Wire color	Function	Analog terminal
Black	Signal	1
White	Signal reference	2
Clear	Shield	⏏

Wire color	Function	Analog terminal
White	Total irradiance	4
Brown	Diffuse irradiance	5
Green	Signal ground	6
Gray	Power ground	G
Pink	Sensor power	12V
Clear	Shield	⏏

¹The yellow, blue, and red wires are not connected.

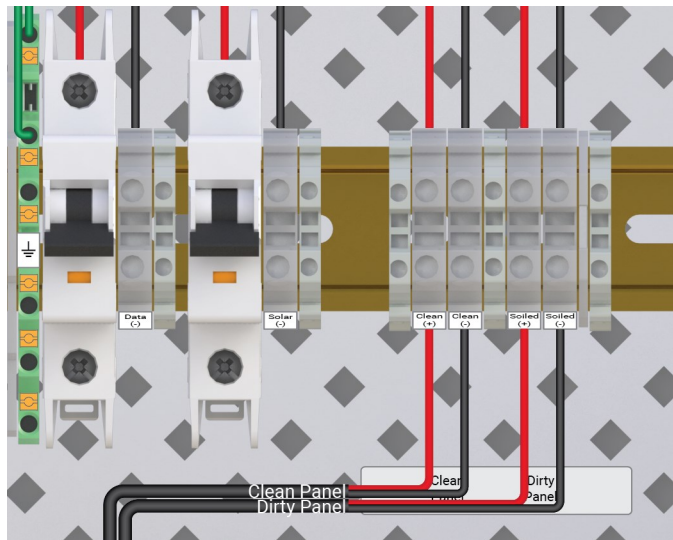

Figure 4-6. Clean and soiled solar panel connections

Table 4-6: Clean solar panel connections	
Wire color	Analog terminal
Red	Clean Panel (+)
Black	Clean Panel (-)

Table 4-7: Soiled solar panel connections	
Wire color	Analog terminal
Red	Soiled Panel (+)
Black	Soiled Panel (-)

4.3 Power connections

The following figure and tables provide the power connections.

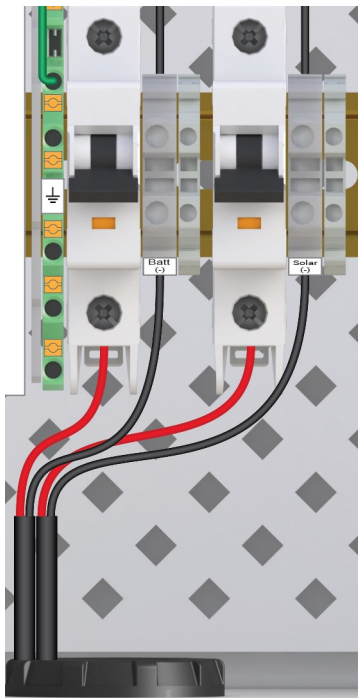

Figure 4-7. Power connections

Table 4-8: Solar panel connections			
Solar panel terminal	Wire color	Function	Connection
Solar panel +	Red	Power	10A breaker
Solar panel –	Black	Ground	Solar (-)

Table 4-9: 24 VDC power supply connections			
Power supply terminal	Wire color	Function	Connection
V +	Red	Power	10A breaker
G	Black	Ground	Batt (-)

5. Operation

The SunScout has a large button on the bottom of the enclosure. Firmly pressing the button provides the following functions:

1 to 3 times:

Indicates that the **Clean (or reference)** solar panel has been cleaned and a timestamp will be recorded in the program to indicate this. Clean the **Clean (or reference)** solar panel on a consistent schedule, such as once a day, week, or month. Accurate soiling data requires a consistent cleaning schedule for the **Clean (or reference)** solar panel.

6+ times:

Indicates that both the **Clean (or reference)** and **Soiled (or test)** solar panels have been cleaned. This will recalibrate the program to show a soiling ratio of 1 on the top of the hour or the next day. This needs to be done when initially installing this system after cleaning both the **Clean (or reference)** and **Soiled (or test)** solar panels, and/or when all the solar panels on the site have been cleaned. In either of those scenarios, pressing the button 6+ times will create two timestamps indicating that both the **Clean (or reference)** and **Soiled (or test)** solar panels have been cleaned.

NOTE:

When the button is pressed for the first time, the program will initiate a 60 second timer. This will record the desired amount of button presses within that time frame. Once the 60 second window has passed the appropriate time stamp(s) will be recorded.

3 year limited warranty

Campbell Scientific warrants to the original end-user only that the products will conform to the specification and be free of material defects in materials and workmanship for a period of three years (the "Initial Warranty Period") from the date of original shipment to the original consumer. To be warranted for three years (the "Full Warranty Period"), the end-user will need to fulfill the following requirements before the end of the initial warranty period:

1. Recalibrate the pyranometers within manufacturer's recommended interval.

Model	Manufacturer	ISO9060:2018 Classification	Manufacturer's Recommended Recalibration Interval
SR30	Hukseflux	Class A Spectrally Flat	2 Years
SR05	Hukseflux	Class C Spectrally Flat	2 Years

Contact Campbell Scientific for more information on the recalibration process.

2. The METSENS500 internal relative humidity and ambient temperature chip should undergo routine maintenance and calibration, ideally within 24 months of first installation. This ensures optimal performance of the product. Please contact Campbell Scientific for further details on this standard procedure.

Any products supplied by Campbell Scientific as part of the SunScout Solar Resource Assessment Station (SunScout) but manufactured by others are warranted to the Initial Warranty Period. Meeting the above provisions extends the warranty to the Full Warranty Period. If a non-Campbell Scientific made product carries a longer warranty, for example, the Hukseflux SR30 pyranometer is warranted for 5 years, Campbell Scientific will warrant the product to the full extent of the original manufacturer's warranty.

If a product is determined to be defective in materials or workmanship, Campbell Scientific will, at Campbell Scientific's option, repair, replace, or refund the purchase price of the product without charge. This warranty does not cover damage due to improper installation, integration, operation, maintenance, use, storage, accident, misuse, or damages due to lightning, or any unauthorized applications or modifications. This warranty also will not apply if any seal on any product instrument or product sensor is broken, if any cable has been severed, or the equipment

was not adequately electrically and physically grounded. Finally, this warranty does not cover any damage or malfunctions caused by unauthorized parts or services.

To return a defective product, the requestor must obtain a Campbell Scientific written authorization in the form of a Return Material Authorization ("RMA") number. The requestor must contact Campbell Scientific Calibration and Repair Services for an RMA number. The requestor must provide the serial number of the product and the date of purchase. No products will be accepted for repair or replacement work without an associated RMA number. The product must be returned, postage prepaid, to Campbell Scientific with a brief description of the problem, RMA number, and a return address with contact information (phone number and email address). Campbell Scientific will return any repaired or replaced products and cover the return freight costs, except when otherwise noted.

To return pyranometers for recommended recalibrations within the initial warranty period or following completion of the warranty period, the same RMA process and requirements apply. To return the Metsens500 for internal chip replacement, the same RMA process and requirements apply.

EXCEPT AS EXPRESSLY SET FORTH ABOVE, THIS WARRANTY CONSTITUTES THE SOLE AND EXCLUSIVE REMEDY OF BUYER AND THE SOLE AND EXCLUSIVE LIABILITY OF SELLER AND IS IN LIEU OF ALL OTHER WARRANTIES, EXPRESS OR IMPLIED, INCLUDING WITHOUT LIMITATION THE WARRANTY OF MERCHANTABILITY OR FITNESS FOR ANY PARTICULAR PURPOSE OR USE. THIS WARRANTY DOES NOT EXTEND TO ANY PRODUCT WHICH MAY HAVE BEEN DAMAGED AS A RESULT OF ACCIDENT, MISUSE, ABUSE, OR AS A RESULT OF MODIFICATION BY ANYONE OTHER THAN CAMPBELL SCIENTIFIC OR AN AUTHORIZED REPRESENTATIVE. TO REMOVE ANY DOUBT, CAMPBELL SCIENTIFIC'S TOTAL LIABILITY SHALL NOT EXCEED THE PURCHASE PRICE OF THE PRODUCT.

Assistance

Products may not be returned without prior authorization.

Products shipped to Campbell Scientific require a Returned Materials Authorization (RMA) or Repair Reference number and must be clean and uncontaminated by harmful substances, such as hazardous materials, chemicals, insects, and pests. Please complete the required forms prior to shipping equipment.

Campbell Scientific regional offices handle repairs for customers within their territories. Please see the back page for the Global Sales and Support Network or visit www.campbellsci.com/contact  to determine which Campbell Scientific office serves your country.

To obtain a Returned Materials Authorization or Repair Reference number, contact your CAMPBELL SCIENTIFIC regional office. Please write the issued number clearly on the outside of the shipping container and ship as directed.

For all returns, the customer must provide a "Statement of Product Cleanliness and Decontamination" or "Declaration of Hazardous Material and Decontamination" form and comply with the requirements specified in it. The form is available from your CAMPBELL SCIENTIFIC regional office. Campbell Scientific is unable to process any returns until we receive this statement. If the statement is not received within three days of product receipt or is incomplete, the product will be returned to the customer at the customer's expense. Campbell Scientific reserves the right to refuse service on products that were exposed to contaminants that may cause health or safety concerns for our employees.

Safety

DANGER — MANY HAZARDS ARE ASSOCIATED WITH INSTALLING, USING, MAINTAINING, AND WORKING ON OR AROUND TRIPODS, TOWERS, AND ANY ATTACHMENTS TO TRIPODS AND TOWERS SUCH AS SENSORS, CROSSARMS, ENCLOSURES, ANTENNAS, ETC. FAILURE TO PROPERLY AND COMPLETELY ASSEMBLE, INSTALL, OPERATE, USE, AND MAINTAIN TRIPODS, TOWERS, AND ATTACHMENTS, AND FAILURE TO HEED WARNINGS, INCREASES THE RISK OF DEATH, ACCIDENT, SERIOUS INJURY, PROPERTY DAMAGE, AND PRODUCT FAILURE. TAKE ALL REASONABLE PRECAUTIONS TO AVOID THESE HAZARDS. CHECK WITH YOUR ORGANIZATION'S SAFETY COORDINATOR (OR POLICY) FOR PROCEDURES AND REQUIRED PROTECTIVE EQUIPMENT PRIOR TO PERFORMING ANY WORK.

Use tripods, towers, and attachments to tripods and towers only for purposes for which they are designed. Do not exceed design limits. Be familiar and comply with all instructions provided in product manuals. Manuals are available at www.campbellsci.com You are responsible for conformance with governing codes and regulations, including safety regulations, and the integrity and location of structures or land to which towers, tripods, and any attachments are attached. Installation sites should be evaluated and approved by a qualified engineer. If questions or concerns arise regarding installation, use, or maintenance of tripods, towers, attachments, or electrical connections, consult with a licensed and qualified engineer or electrician.

General

- Protect from over-voltage.
- Protect electrical equipment from water.
- Protect from electrostatic discharge (ESD).
- Protect from lightning.
- Prior to performing site or installation work, obtain required approvals and permits. Comply with all governing structure-height regulations, such as those of the FAA in the USA.
- Use only qualified personnel for installation, use, and maintenance of tripods and towers, and any attachments to tripods and towers. The use of licensed and qualified contractors is highly recommended.
- Read all applicable instructions carefully and understand procedures thoroughly before beginning work.
- Wear a hardhat and eye protection, and take other appropriate safety precautions while working on or around tripods and towers.
- Do not climb tripods or towers at any time, and prohibit climbing by other persons. Take reasonable precautions to secure tripod and tower sites from trespassers.
- Use only manufacturer recommended parts, materials, and tools.

Utility and Electrical

- You can be killed or sustain serious bodily injury if the tripod, tower, or attachments you are installing, constructing, using, or maintaining, or a tool, stake, or anchor, come in contact with overhead or underground utility lines.
- Maintain a distance of at least one-and-one-half times structure height, 6 meters (20 feet), or the distance required by applicable law, whichever is greater, between overhead utility lines and the structure (tripod, tower, attachments, or tools).
- Prior to performing site or installation work, inform all utility companies and have all underground utilities marked.
- Comply with all electrical codes. Electrical equipment and related grounding devices should be installed by a licensed and qualified electrician.
- Only use power sources approved for use in the country of installation to power Campbell Scientific devices.

Elevated Work and Weather

- Exercise extreme caution when performing elevated work.
- Use appropriate equipment and safety practices.
- During installation and maintenance, keep tower and tripod sites clear of un-trained or non-essential personnel. Take precautions to prevent elevated tools and objects from dropping.
- Do not perform any work in inclement weather, including wind, rain, snow, lightning, etc.

Internal Battery

- Be aware of fire, explosion, and severe-burn hazards.
- Misuse or improper installation of the internal lithium battery can cause severe injury.

- Do not recharge, disassemble, heat above 100 °C (212 °F), solder directly to the cell, incinerate, or expose contents to water. Dispose of spent batteries properly.

Use and disposal of batteries

- Where batteries need to be transported to the installation site, ensure they are packed to prevent the battery terminals shorting which could cause a fire or explosion. Especially in the case of lithium batteries, ensure they are packed and transported in a way that complies with local shipping regulations and the safety requirements of the carriers involved.
- When installing the batteries follow the installation instructions very carefully. This is to avoid risk of damage to the equipment caused by installing the wrong type of battery or reverse connections.
- When disposing of used batteries, it is still important to avoid the risk of shorting. Do not dispose of the batteries in a fire as there is risk of explosion and leakage of harmful chemicals into the environment. Batteries should be disposed of at registered recycling facilities.

Avoiding unnecessary exposure to radio transmitter radiation

- Where the equipment includes a radio transmitter, precautions should be taken to avoid unnecessary exposure to radiation from the antenna. The degree of caution required varies with the power of the transmitter, but as a rule it is best to avoid getting closer to the antenna than 20 cm (8 inches) when the antenna is active. In particular keep your head away from the antenna. For higher power radios (in excess of 1 W ERP) turn the radio off when servicing the system, unless the antenna is installed away from the station, e.g. it is mounted above the system on an arm or pole.

Maintenance

- Periodically (at least yearly) check for wear and damage, including corrosion, stress cracks, frayed cables, loose cable clamps, cable tightness, etc. and take necessary corrective actions.
- Periodically (at least yearly) check electrical ground connections.

WHILE EVERY ATTEMPT IS MADE TO EMBODY THE HIGHEST DEGREE OF SAFETY IN ALL CAMPBELL SCIENTIFIC PRODUCTS, THE CUSTOMER ASSUMES ALL RISK FROM ANY INJURY RESULTING FROM IMPROPER INSTALLATION, USE, OR MAINTENANCE OF TRIPODS, TOWERS, OR ATTACHMENTS TO TRIPODS AND TOWERS SUCH AS SENSORS, CROSSARMS, ENCLOSURES, ANTENNAS, ETC.

Global Sales and Support Network

A worldwide network to help meet your needs



Campbell Scientific Regional Offices

Australia

Location: Garbutt, QLD Australia
Phone: 61.7.4401.7700
Email: info@campbellsci.com.au
Website: www.campbellsci.com.au

Brazil

Location: São Paulo, SP Brazil
Phone: 11.3732.3399
Email: vendas@campbellsci.com.br
Website: www.campbellsci.com.br

Canada

Location: Edmonton, AB Canada
Phone: 780.454.2505
Email: dataloggers@campbellsci.ca
Website: www.campbellsci.ca

China

Location: Beijing, P. R. China
Phone: 86.10.6561.0080
Email: info@campbellsci.com.cn
Website: www.campbellsci.com.cn

Costa Rica

Location: San Pedro, Costa Rica
Phone: 506.2280.1564
Email: info@campbellsci.cc
Website: www.campbellsci.cc

France

Location: Montrouge, France
Phone: 0033.0.1.56.45.15.20
Email: info@campbellsci.fr
Website: www.campbellsci.fr

Germany

Location: Bremen, Germany
Phone: 49.0.421.460974.0
Email: info@campbellsci.de
Website: www.campbellsci.de

India

Location: New Delhi, DL India
Phone: 91.11.46500481.482
Email: info@campbellsci.in
Website: www.campbellsci.in

South Africa

Location: Stellenbosch, South Africa
Phone: 27.21.8809960
Email: sales@campbellsci.co.za
Website: www.campbellsci.co.za

Spain

Location: Barcelona, Spain
Phone: 34.93.2323938
Email: info@campbellsci.es
Website: www.campbellsci.es

Thailand

Location: Bangkok, Thailand
Phone: 66.2.719.3399
Email: info@campbellsci.asia
Website: www.campbellsci.asia

UK

Location: Shephed, Loughborough, UK
Phone: 44.0.1509.601141
Email: sales@campbellsci.co.uk
Website: www.campbellsci.co.uk

USA

Location: Logan, UT USA
Phone: 435.227.9120
Email: info@campbellsci.com
Website: www.campbellsci.com