

SR20-D2

ISO Spectrally Flat Class A
(Secondary Standard)
Pyranometer



Table of contents

1. SR20-D2 introduction	1
2. Siting	1
3. Mounting procedure	1
4. SR20-D2 wiring	3
4. RS-485 default configuration	4
5. SR20-D2 register map	4
6. RS-485 programming	5
7. SR20-D2 example program	5
8. Maintenance and troubleshooting	9

1. SR20-D2 introduction

The SR20-D2, manufactured by Hukseflux Thermal Sensors, is an ISO 9060 digital spectrally flat Class A (secondary standard) pyranometer that measures solar short-wave radiation in a full hemisphere of the sky. It has a built-in case-temperature sensor and embedded heater for removing dew and light rain. It connects directly to Campbell Scientific data loggers and is designed for applications that require high measurement accuracy in demanding applications such as scientific meteorological observation networks and utility scale solar-energy-power production sites.

2. Siting

The solar radiation sensor is usually installed horizontally, but can also be installed at any angle including an inverted position. Site the sensor to allow easy access for maintenance while ideally avoiding any obstructions or reflections above the plane of the sensing element. It is important to mount the sensor such that a shadow or a reflection will not be cast on it at any time. If this is not possible, try to choose a site where any obstruction over the azimuth range between earliest sunrise and latest sunset has an elevation not exceeding 5°. Diffuse solar radiation is less influenced by obstructions near the horizon. The sensor should be mounted with the cable pointing towards the nearest magnetic pole. For example, in the northern hemisphere, point the cable toward the North Pole.

3. Mounting procedure

Required tools:

- Diopter
- Solar compass
- 8 mm (5/16-inch) open-end wrench for U-bolt nuts

1. On a level surface, level the solar radiation sensor using the leveling feet on the sensor. Alternatively, remove the sensor leveling feet to allow it to be mounted directly to the mounting bracket.

- Secure the solar radiation sensor to the mounting bracket. The blue dots in the following figure indicate the mounting holes used for this pyranometer.

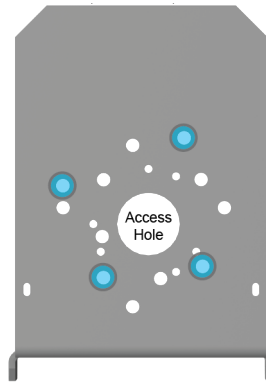

- Using a diopter in combination with a solar compass, install and orient the crossarm on the tripod or the mast. If installing the mounting bracket on a vertical pole, ensure the pole is truly vertical.
- Secure the mounting bracket to the crossarm or vertical pole using the hardware included with the mounting bracket. The CM255 uses one U-bolt, nuts, flat washers, and lock washers to mount the bracket, as shown in the following figure.

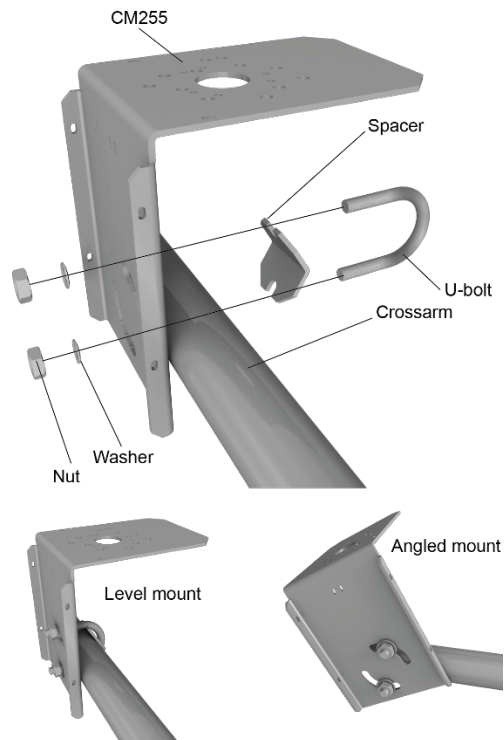

- For pyranometers mounted horizontally, ensure the mounting bracket is horizontal in two dimensions. For pyranometers mounted at an angle, set the mounting bracket angle to the desired angle prior to tightening the mounting hardware.

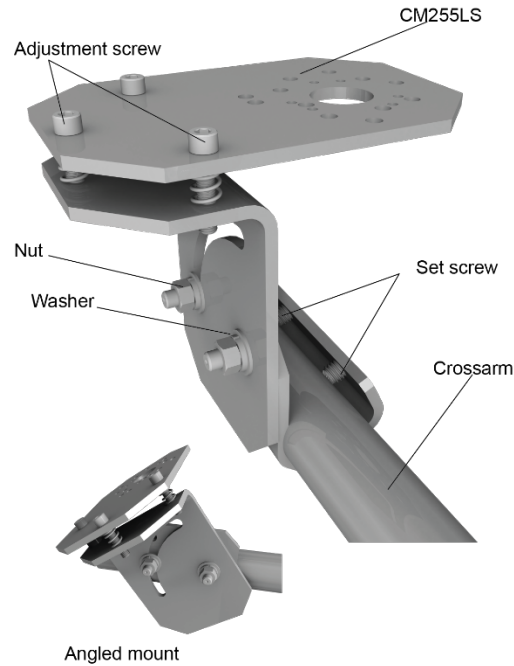

- Verify mounting hardware is firmly tightened, and that the mounting bracket is at the desired angle.

4. SR20-D2 wiring

Table 4-1: Pin-out, wire color, function, and data logger connection

Wire color	Pin out		Function	Data logger connection
	-PT	-PW		
Green	5	2	RS-485A	A-, C (odd)
White	7	4	RS-485B	B+, C (even)
Red	2	1	Power in (12 V)	12V
Black	6	3	Power ground	G
Clear	9	5	Shield	\perp (analog ground)

¹ Assumes the sensor directly connects to the data logger.

4. RS-485 default configuration

The default RS-485 settings are: 19200 baud rate, 8 data bits, even parity, one stop bit. This configuration is used for most Modbus networks.

5. SR20-D2 register map

Table 5-1 (p. 4) provides the register map for the most commonly used values. A comprehensive register map is available in the Hukseflux manual.

Starting Register Number	Register Count	Data Format	Units	Description
1	1	Signed 16 bit integer		Modbus address
3	2	Signed 32 bit integer	mW/m ²	Irradiance (temperature compensated signal)
5	2	Signed 32 bit integer	mW/m ²	Irradiance (temperature uncompensated signal)
7	1	Signed 16 bit integer	0.01 °C	Sensor body temperature
8	1	Signed 16 bit integer	x 0.1 Ω	Sensor electrical resistance
9	1	Signed 16 bit integer		Scaling factor irradiance
10	1	Signed 16 bit integer		Scaling factor temperature
11	2	Signed 32 bit integer	nV	Sensor voltage output
41	1	Signed 16 bit integer		Serial number
42	2	Float	μV/W/m ²	Sensor sensitivity
47	2	Signed 32 bit integer		Calibration date
99	1	Signed 16 bit integer	x 0.01 %	Humidity

6. RS-485 programming

The RS-485 output can be directly read by a MeteoPV, CR6-series, CR1000X-series, or Modbus RTU RS-485 network. Other Campbell Scientific data loggers can use an MD485 multidrop interface to read the RS-485 output (refer to the MD485 manual).

A CR6 or CR1000X data logger programmed as a Modbus Master can retrieve the values stored in the Input Registers. To do this, the CRBasic program requires a `SerialOpen()` instruction followed by the `ModbusMaster()` instruction.

The `SerialOpen` instruction has the following syntax:

`SerialOpen` (ComPort, Baud, Format, TXDelay, BufferSize, Mode)

The `Format` is typically set to logic 1 low; even parity, one stop bit, 8 data bits. The `Mode` parameter should configure the ComPort as RS-485 half-duplex, transparent. The `ModbusMaster()` instruction has the following syntax:

`ModbusMaster` (Result, ComPort, Baud, Addr, Function, Variable, Start, Length, Tries, TimeOut, [ModbusOption])

The `Addr` parameter must match the sensor Modbus address. To collect all of the values, the `Start` parameter needs to be 1 and the `Length` parameter needs to correspond with the register count (see [SR20-D2 register map](#) (p. 4)). `ModbusOption` is an optional parameter described in the CRBasic Editor Help. Refer to [SR20-D2 example program](#) (p. 5) for more information.

7. SR20-D2 example program

Wire color	Function	Data logger connection
Green	RS-485A	C5
White	RS-485B	C6
Red	Power in (12 V)	12V
Black	Power ground	G
Clear	Shield	⏏ (analog ground)

CRBasic Example 1: CR1000X program for measuring the SR20-D2

```
'CR1000X Series Datalogger
'Hukseflux SR20-D2 Pyranometer
'SR20 is a ISO 9060 Secondary Standard digital pyranometer
'D2 uses Modbus RS-485 protocol
'PN 34088 SR20-D2CBL-L (CSI's SR20D2 Cable)
Dim SR20D2(15) As Long
Public SR20D2_IRR_TC 'Temperature compensated x 0.01 W/M^2
Public SR20D2_IRR 'Uncompensated x 0.01 W/M^2
Public SR20D2_BodyTemp As Float
Public SR20D2_SerialNumber As Float
Public SR20D2_CalDate As Long
Public SR20D2_Humidity As Float
Public SR20D2_ScaleFactor_IRR As Long
Public SR20D2_ScaleFactor_BodyTemp As Long
Public SR20D2_ElecResistance As Long
Public SR20D2_VoltageOut As Float
Public ModbusResult_IRR_TC
Public ModbusResult_IRR
Public ModbusResult_BodyTemp
Public ModbusResult_SN
Public ModbusResult_CalDate
Public ModbusResult_Humidity
Public ModbusResult_SFIRR
Public ModbusResult_SRTemp
Public ModbusResult_ElecRes
Public ModbusResult_VoltOut
Units SR20D2_IRR = W/m^2
Units SR20D2_IRR_TC = W/m^2
Units SR20D2_BodyTemp = DegC
Units SR20D2_Humidity = %
Units SR20D2_ElecResistance = Ohm
Units SR20D2_VoltageOut = uV
DataTable (OneMin,1,-1)
  DataInterval (0,1,Min,10)
  Average (1,SR20D2_IRR,IEEE4,False)
  Average (1,SR20D2_IRR_TC,IEEE4,False)
  Maximum (1,SR20D2_IRR_TC,IEEE4,False,False)
  Minimum (1,SR20D2_IRR_TC,IEEE4,False,False)
  StdDev (1,SR20D2_IRR_TC,IEEE4,False)
  Average (1,SR20D2_BodyTemp,IEEE4,False)
EndTable
DataTable (SR20D2_MetaData,1,-1)
  Sample (1,SR20D2_ElecResistance,IEEE4)
  Sample (1,SR20D2_VoltageOut,IEEE4)
  Sample (1,SR20D2_Humidity,IEEE4)
```

CRBasic Example 1: CR1000X program for measuring the SR20-D2

```
EndTable
DataTable (SR20D2_SensorID,1,100)
  Sample (1,SR20D2_SerialNumber,FP2)
  Sample (1,SR20D2_CalDate,Long)
  Sample (1,SR20D2_ScaleFactor_IRR,FP2)
  Sample (1,SR20D2_ScaleFactor_BodyTemp,FP2)
EndTable
BeginProg
  SerialOpen (ComC5,19200,2,0,50,4)
  ModbusMaster (ModbusResult_SN,ComC5,19200,53,4,SR20D2(1),41,1,1,100,3)
  'Serial Number
  SR20D2_SerialNumber = SR20D2(1)
  ModbusMaster (ModbusResult_CalDate,ComC5,19200,53,4,SR20D2(2),47,1,1,100,2)
  'Cal Date
  SR20D2_CalDate = SR20D2(2)
  ModbusMaster (ModbusResult_SFIRR,ComC5,19200,53,4,SR20D2(3),9,1,1,100,3)
  'Scaling Factor IRR
  SR20D2_ScaleFactor_IRR = SR20D2(3)
  ModbusMaster (ModbusResult_SRTemp,ComC5,19200,53,4,SR20D2(4),10,1,1,100,3)
  'Scaling Factor Temp
  SR20D2_ScaleFactor_BodyTemp = SR20D2(4)
  ModbusMaster (ModbusResult_ElecRes,ComC5,19200,53,4,SR20D2(10), _
  8,1,1,100,1)
  'Electrical Resistance
  SR20D2_ElecResistance = SR20D2(10)/10
  ModbusMaster (ModbusResult_VoltOut,ComC5,19200,53,4,SR20D2(11), _
  11,2,1,100,2)
  'Voltage output
  SR20D2_VoltageOut = SR20D2(11)
  ModbusMaster (ModbusResult_Humidity,ComC5,19200,53,4,SR20D2(13),99,1,1,100,3)
  'Humidity
  SR20D2_Humidity = SR20D2(13)/100
  Scan (1,Sec,0,0)
  ModbusMaster (ModbusResult_IRR_TC,ComC5,19200,53,4,SR20D2(5),3,2,1,100,2)
  'Irradiance temperature compensated
  SR20D2_IRR_TC = SR20D2(5)/SR20D2_ScaleFactor_IRR
  ModbusMaster (ModbusResult_IRR,ComC5,19200,53,4,SR20D2(7),5,2,1,100,2)
  'Irradiance uncompensated
  SR20D2_IRR = SR20D2(7)/SR20D2_ScaleFactor_IRR
  ModbusMaster (ModbusResult_BodyTemp,ComC5,19200,53,4,SR20D2(9),7,1,1,100,1)
  'Body Temp
  SR20D2_BodyTemp = SR20D2(9)/SR20D2_ScaleFactor_BodyTemp
  CallTable OneMin
NextScan
SlowSequence
Scan (6,Hr,0,0)
  ModbusMaster (ModbusResult_ElecRes,ComC5,19200,53,4,SR20D2(10),8,1,1,100,1)
```

CRBasic Example 1: CR1000X program for measuring the SR20-D2

```
'Electrical Resistance
SR20D2_ElecResistance = SR20D2(10)/10
ModbusMaster (ModbusResult_VoltOut,ComC5,19200,53,4,SR20D2(11), _
11,2,1,100,2)
'Voltage output
SR20D2_VoltageOut = SR20D2(11)
ModbusMaster (ModbusResult_Humidity,ComC5,19200,53,4,SR20D2(13), _
99,1,1,100,3)
'Humidity
SR20D2_Humidity = SR20D2(13)/100
CallTable SR20D2_MetaData
NextScan
SlowSequence
Scan (1,Sec,0,1)
If SR20D2_SerialNumber = 0 Then
  ModbusMaster (ModbusResult_SN,ComC5,19200,53,4,SR20D2(1),41,1,1,100,3)
  'Serial Number
  SR20D2_SerialNumber = SR20D2(1)
  ModbusMaster (ModbusResult_CalDate,ComC5,19200,53,4,SR20D2(2), _
47,1,1,100,2)
  'Cal Date
  SR20D2_CalDate = SR20D2(2)
  ModbusMaster (ModbusResult_SFIRR,ComC5,19200,53,4,SR20D2(3),9,1,1,100,3)
  'Scaling Factor IRR
  SR20D2_ScaleFactor_IRR = SR20D2(3)
  ModbusMaster (ModbusResult_SRTemp,ComC5,19200,53,4,SR20D2(4),10,1,1,100,3)
  'Scaling Factor Temp
  SR20D2_ScaleFactor_BodyTemp = SR20D2(4)
  ModbusMaster (ModbusResult_ElecRes,ComC5,19200,53,4,SR20D2(10), _
8,1,1,100,1)
  'Electrical Resistance
  SR20D2_ElecResistance = SR20D2(10)/10
  ModbusMaster (ModbusResult_VoltOut,ComC5,19200,53,4,SR20D2(11), _
11,2,1,100,2)
  'Voltage output
  SR20D2_VoltageOut = SR20D2(11)
  ModbusMaster (ModbusResult_Humidity,ComC5,19200,53,4,SR20D2(13), _
99,1,1,100,3)
  'Humidity
  SR20D2_Humidity = SR20D2(13)/100
EndIf
CallTable SR20D2_SensorID
NextScan
EndProg
```

8. Maintenance and troubleshooting

The SR20-D2 has no service items requiring scheduled replacement. There is no accessible desiccant cartridge to maintain. Use pure alcohol or distilled water and a lint-free cloth to clean the dome, removing smears and deposits. Local conditions and application dictate cleaning interval. Sophisticated research applications require daily cleaning. For typical PV applications, clean once per week, bi-monthly, or monthly. The SR20-D2 should be recalibrated following industry standard best practices such as ASTM G167, ISO 9846, ASTM E824 or ASTM G207 by an accredited lab. The recommended recalibration interval is two years. Contact Campbell Scientific for more information.

Unexpected results typically occur because of improper wiring or programming, electromagnetic radiation, or damaged cables. Ensure that the data logger program includes the correct parameters for the measurement instructions. Check for the presence of strong sources of electromagnetic radiation and use the 50 or 60 Hz integration option in the data logger program if electromagnetic radiation can be a problem. Check the cable for damage and ensure that it is properly connected to the data logger.

Limited warranty

Products manufactured by Campbell Scientific are warranted by Campbell Scientific to be free from defects in materials and workmanship under normal use and service for twelve months from the date of shipment unless otherwise specified on the corresponding product webpage. See Product Details on the Ordering Information pages at www.campbellsci.com. Other manufacturer's products, that are resold by Campbell Scientific, are warranted only to the limits extended by the original manufacturer.

Refer to www.campbellsci.com/terms#warranty for more information.

CAMPBELL SCIENTIFIC EXPRESSLY DISCLAIMS AND EXCLUDES ANY IMPLIED WARRANTIES OF MERCHANTABILITY OR FITNESS FOR A PARTICULAR PURPOSE. Campbell Scientific hereby disclaims, to the fullest extent allowed by applicable law, any and all warranties and conditions with respect to the Products, whether express, implied or statutory, other than those expressly provided herein.

Assistance

Products may not be returned without prior authorization.

Refer to www.campbellsci.com/repair for up-to-date repair information.

The following contact information is for US and international customers residing in countries served by Campbell Scientific, Inc. directly. Campbell Scientific regional offices handle repairs for customers within their territories. Please visit www.campbellsci.com/contact to determine which Campbell Scientific office serves your country.

To obtain a Returned Materials Authorization (RMA) number, contact CAMPBELL SCIENTIFIC, INC., phone (435) 227-9000. Please write the issued RMA number clearly on the outside of the shipping container. Campbell Scientific's shipping address is:

CAMPBELL SCIENTIFIC, INC.

RMA# _____

815 West 1800 North

Logan, Utah 84321-1784

For all returns, the customer must fill out a "Statement of Product Cleanliness and Decontamination" form and comply with the requirements specified in it. The form is available from our website at www.campbellsci.com/repair. A completed form must be either emailed to repair@campbellsci.com or faxed to (435) 227-9106. Campbell Scientific is unable to process any returns until we receive this form. If the form is not received within three days of product receipt or is incomplete, the product will be returned to the customer at the customer's expense. Campbell Scientific reserves the right to refuse service on products that were exposed to contaminants that may cause health or safety concerns for our employees.

Safety

DANGER — MANY HAZARDS ARE ASSOCIATED WITH INSTALLING, USING, MAINTAINING, AND WORKING ON OR AROUND TRIPODS, TOWERS, AND ANY ATTACHMENTS TO TRIPODS AND TOWERS SUCH AS SENSORS, CROSSARMS, ENCLOSURES, ANTENNAS, ETC. FAILURE TO PROPERLY AND COMPLETELY ASSEMBLE, INSTALL, OPERATE, USE, AND MAINTAIN TRIPODS, TOWERS, AND ATTACHMENTS, AND FAILURE TO HEED WARNINGS, INCREASES THE RISK OF DEATH, ACCIDENT, SERIOUS INJURY, PROPERTY DAMAGE, AND PRODUCT FAILURE. TAKE ALL REASONABLE PRECAUTIONS TO AVOID THESE HAZARDS. CHECK WITH YOUR ORGANIZATION'S SAFETY COORDINATOR (OR POLICY) FOR PROCEDURES AND REQUIRED PROTECTIVE EQUIPMENT PRIOR TO PERFORMING ANY WORK.

Use tripods, towers, and attachments to tripods and towers only for purposes for which they are designed. Do not exceed design limits. Be familiar and comply with all instructions provided in product manuals. Manuals are available at www.campbellsci.com. You are responsible for conformance with governing codes and regulations, including safety regulations, and the integrity and location of structures or land to which towers, tripods, and any attachments are attached. Installation sites should be evaluated and approved by a qualified engineer. If questions or concerns arise regarding installation, use, or maintenance of tripods, towers, attachments, or electrical connections, consult with a licensed and qualified engineer or electrician.

General

- Protect from over-voltage.
- Protect electrical equipment from water.
- Protect from electrostatic discharge (ESD).
- Protect from lightning.
- Prior to performing site or installation work, obtain required approvals and permits. Comply with all governing structure-height regulations, such as those of the FAA in the USA.
- Use only qualified personnel for installation, use, and maintenance of tripods and towers, and any attachments to tripods and towers. The use of licensed and qualified contractors is highly recommended.
- Read all applicable instructions carefully and understand procedures thoroughly before beginning work.
- Wear a **hardhat** and **eye protection**, and take **other appropriate safety precautions** while working on or around tripods and towers.
- **Do not climb** tripods or towers at any time, and prohibit climbing by other persons. Take reasonable precautions to secure tripod and tower sites from trespassers.
- Use only manufacturer recommended parts, materials, and tools.

Utility and Electrical

- **You can be killed** or sustain serious bodily injury if the tripod, tower, or attachments you are installing, constructing, using, or maintaining, or a tool, stake, or anchor, come in **contact with overhead or underground utility lines**.
- Maintain a distance of at least one-and-one-half times structure height, 20 feet, or the distance required by applicable law, **whichever is greater**, between overhead utility lines and the structure (tripod, tower, attachments, or tools).
- Prior to performing site or installation work, inform all utility companies and have all underground utilities marked.
- Comply with all electrical codes. Electrical equipment and related grounding devices should be installed by a licensed and qualified electrician.

Elevated Work and Weather

- Exercise extreme caution when performing elevated work.
- Use appropriate equipment and safety practices.
- During installation and maintenance, keep tower and tripod sites clear of un-trained or non-essential personnel. Take precautions to prevent elevated tools and objects from dropping.
- Do not perform any work in inclement weather, including wind, rain, snow, lightning, etc.

Maintenance

- Periodically (at least yearly) check for wear and damage, including corrosion, stress cracks, frayed cables, loose cable clamps, cable tightness, etc. and take necessary corrective actions.
- Periodically (at least yearly) check electrical ground connections.

Internal Battery

- Be aware of fire, explosion, and severe-burn hazards.
- Misuse or improper installation of the internal lithium battery can cause severe injury.
- Do not recharge, disassemble, heat above 100 °C (212 °F), solder directly to the cell, incinerate, or expose contents to water. Dispose of spent batteries properly.

WHILE EVERY ATTEMPT IS MADE TO EMBODY THE HIGHEST DEGREE OF SAFETY IN ALL CAMPBELL SCIENTIFIC PRODUCTS, THE CUSTOMER ASSUMES ALL RISK FROM ANY INJURY RESULTING FROM IMPROPER INSTALLATION, USE, OR MAINTENANCE OF TRIPODS, TOWERS, OR ATTACHMENTS TO TRIPODS AND TOWERS SUCH AS SENSORS, CROSSARMS, ENCLOSURES, ANTENNAS, ETC.



Global Sales & Support Network

A worldwide network to help meet your needs



Campbell Scientific regional offices

Australia

Location: Garbutt, QLD Australia
Phone: 61.7.4401.7700
Email: info@campbellsci.com.au
Website: www.campbellsci.com.au

Brazil

Location: São Paulo, SP Brazil
Phone: 11.3732.3399
Email: vendas@campbellsci.com.br
Website: www.campbellsci.com.br

Canada

Location: Edmonton, AB Canada
Phone: 780.454.2505
Email: dataloggers@campbellsci.ca
Website: www.campbellsci.ca

China

Location: Beijing, P. R. China
Phone: 86.10.6561.0080
Email: info@campbellsci.com.cn
Website: www.campbellsci.com.cn

Costa Rica

Location: San Pedro, Costa Rica
Phone: 506.2280.1564
Email: info@campbellsci.cc
Website: www.campbellsci.cc

France

Location: Vincennes, France
Phone: 0033.0.1.56.45.15.20
Email: info@campbellsci.fr
Website: www.campbellsci.fr

Germany

Location: Bremen, Germany
Phone: 49.0.421.460974.0
Email: info@campbellsci.de
Website: www.campbellsci.de

India

Location: New Delhi, DL India
Phone: 91.11.46500481.482
Email: info@campbellsci.in
Website: www.campbellsci.in

South Africa

Location: Stellenbosch, South Africa
Phone: 27.21.8809960
Email: sales@campbellsci.co.za
Website: www.campbellsci.co.za

Spain

Location: Barcelona, Spain
Phone: 34.93.2323938
Email: info@campbellsci.es
Website: www.campbellsci.es

Thailand

Location: Bangkok, Thailand
Phone: 66.2.719.3399
Email: info@campbellsci.asia
Website: www.campbellsci.asia

UK

Location: Shepshed, Loughborough, UK
Phone: 44.0.1509.601141
Email: sales@campbellsci.co.uk
Website: www.campbellsci.co.uk

USA

Location: Logan, UT USA
Phone: 435.227.9120
Email: info@campbellsci.com
Website: www.campbellsci.com