

Am Jaegersberg 5-7
24161 Altenholz
Germany

phone.: + 49 – 4 31 – 3 69 60 - 0
fax: + 49 – 4 31 – 3 69 60 - 21
e-mail: info@hydrobios.de
sales@hydrobios.de
web: www.hydrobios.de



Apparatebau GmbH

MULTI PLANKTON SAMPLER MultiNet[®] Type *Maxi*

CATALOGUE NO. 438 140

OPERATION MANUAL

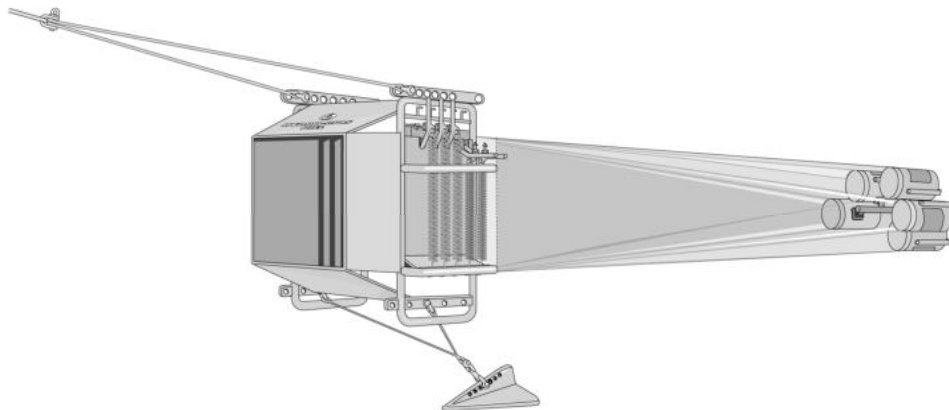

Edition 02/20

© Copyright 2020, by: **HYDRO-BIOS** Apparatebau GmbH

All rights reserved. Reproduction in every form – even by way of abstracts – with explicit permission by **HYDRO-BIOS** Apparatebau GmbH only.

CONTENTS

GENERAL DESCRIPTION	3
STANDARD EQUIPMENT	4
TECHNICAL DATA.....	5
BATTERY CHANGE	6
PREPARATION OF UNDERWATER UNIT AND NET BAGS	7
OPERATING MODES (online or offline mode)	8
WIRING FOR ONLINE OPERATION.....	9
DECK COMMAND UNIT: COMPONENTS AND MAIN SCREEN	10
DECK COMMAND UNIT: ERROR MESSAGES AND MENU SCREEN	11
DECK COMMAND UNIT: QUIT MENU AND MANUAL MOTOR CONTROL	12
DECK COMMAND UNIT: RESET NETNUMBER AND RESET PRESSURE.....	13
FIRST TEST RUN.....	14
SECOND TEST RUN.....	15
OFFLINE OPERATION.....	16
PREPARATION FOR HORIZONTAL COLLECTIONS IN ONLINE MODE.....	18
PREPARATION FOR VERTICAL COLLECTIONS IN ONLINE MODE	19
STRETCHING OF THE SPRINGS OF THE NET CLOSING DEVICE.....	20
RELEASING OF THE SPRINGS OF THE NET CLOSING DEVICE.....	21
OPERATION IN ONLINE MODE	22
OPERATION WITH LESS THAN 9 NET BAGS IN ONLINE MODE	23
HORIZONTAL COLLECTIONS IN ONLINE MODE	24
VERTICAL COLLECTIONS IN ONLINE MODE.....	25
VERTICAL COLLECTIONS IN OFFLINE MODE.....	26
OPERATION WITH LESS THAN 9 NET BAGS IN OFFLINE MODE.....	27
REMOVAL OF THE CANVAS PART	28
MOUNTING OF THE CANVAS PART.....	29
REMOVAL AND MOUNTING INSTRUCTIONS FOR THE MOTOR UNIT	30
LOCALIZATION OF FAULTS	31

GENERAL DESCRIPTION

The **MULT PLANKTON SAMPLER MultiNet Type Maxi** is the second largest member of the family of **MultiNet** Samplers, featuring a net opening of 0.5 sq. m. and 9 sequentially switched net bags. It can be operated in both online and offline mode (see below).

MultiNets can be deployed for horizontal, vertical and oblique collections.

The **MultiNet Type Maxi** consists of a stainless steel frame with canvas part to which 9 net bags are attached by means of zip fasteners. The net bags are opened and closed by means of an arrangement of levers which are triggered by a Motor Unit.

The **MultiNet** may be operated in online or offline mode. In online mode the motor unit has to be connected to the deck command unit with a single- or multi conductor cable. This cable is not included in our scope of delivery. For cable specs see TECHNICAL DATA, page 5. In offline mode the measuring data of all installed sensors are stored in internal memory. The capacity of internal memory is good for 180 to 500 hours of recording, depending on the actual sensor configuration of the **MultiNet**. The stored data can be transferred to a PC by using the data acquisition software **OceanLab**.

The underwater unit is equipped with two electronic flow meters, one inside the net opening for determination of the amount of water passing through the open nets, the other flow meter is mounted on the outer side of the net frame. This flow meter provides a reference against which the amount of clogging can be determined. The measured values of both flow meters are displayed on the deck command unit when in online mode, and are stored in internal memory when in offline mode at a data rate of 1 Hz.

The integrated pressure sensor continuously monitors the current pressure (depth). In online mode the current pressure and active (i.e. open) net bag is signalled to the deck command unit. In offline mode current pressure (depth) and active net number are recorded to internal memory at a data rate of 1 Hz.

The Power Supply of the Underwater Unit is provided by 3 long-time lithium batteries with sufficient capacity for approx. 30 deployments. The batteries are located in an easily removable battery housing.

In online mode the **MultiNet** is controlled / operated by the Deck Command Unit; for offline operation the **MultiNet** is programmed prior to deployment with the PC-software **OceanLab**, enabling the user to pre-select opening resp. closing pressures (depths) for the net bags in successive water layers. In this mode the **MultiNet** may be operated with a normal steel wire.

Since the operation cannot be monitored when in offline mode the **MultiNet** should be only used for vertical sampling when deployed in offline mode to avoid collisions with the ground while towing.

The Underwater Unit is lowered with closed net bags to the greatest desired depth where the first net is opened by push button from the Deck Command Unit if in online mode or automatically by reaching the first pre-programmed net changing pressure after passing the unlocking depth if in offline mode. Upon reaching the next desired depth the first net bag is closed (by push button in online mode or automatically in pre-programmed offline mode) and the next net bag is opened. This procedure is repeated for the following net changes. The 9th bag may be closed in the same way for applications where sampling up to the water surface is undesirable. However, the last net bag **MUST** be closed prior to breaching the water surface.

An upgrade for the motor unit with different sensors of various parameters is available upon request for both online and offline operations.

STANDARD EQUIPMENT

1. 1 Stainless steel frame with canvas part, Motor Unit and Battery Housing made of titanium,
standard operational depth 3000 metres
1 Integrated Pressure Sensor, standard measuring range 3000 dbar
2 Electronic Flowmeters incl. connecting cables
2. 9 Net bags, length 365 cm, standard mesh size 300 micron
Option: other mesh sizes between: 55 and 500 micron
3. 9 Plastic Net Buckets with fixing rings
4. 9 Soft Buckets with Boltrope Fixing Ring
5. 1 Net Bucket Holding Tube
6. 1 Sea-anchor (drogue) with triangle rope for horizontal operations
7. 1 Net Bucket Array for vertical operations
8. 4 Bucket ropes stretch-free, 6 mm Ø x 3.5 m long, incl. adjusting devices and shackles
9. 2 Handling ropes, 14 mm Ø x 3.7 m long, with shackles
10. 1 Tension Lever
11. 1 Depressor with revolving swivel
12. 2 Bridles with shackles
13. 1 Deck Command Unit with mains cable and 4 rubber buttons
14. 4 Screws to mount the Deck Command Unit to a 19"-rack
15. 1 Connecting cable, approx. 3 metres long Fig. 1 C
16. 1 Test run cable, approx. 30 metres long Fig. 1 D
17. 1 Counter plug SUBCONN IL 2 F Fig. 1 A
18. 1 Spare O-ring 10 x 4 for axle duct Fig. 9 C
19. 1 Spare O-ring no. 020 for axle box case Fig. 9 E
20. 1 Spare O-ring no. 151 for pressure housing Fig. 9 H
21. 1 Spare O-ring no. 009 for switch shaft Fig. 9 J
22. 1 Spare O-ring no. 120 for Battery Housing
23. 1 Can O-ring lubricant
24. 1 Can pin lubricant
25. 3 Lithium batteries DURACELL DL 123A / 3 V or equivalent
26. 1 Dummy DC 2 F Fig. 1 E
27. 1 Dummy DC 2 M Fig. 1 B
28. 1 Dummy DCS 2 M-1 Fig. 1 F
29. 1 Dummy DCS 2 M Fig. 1 G
30. 1 Programming cable IL 5 F – Sub-D 9 pin, approx. 30 meters long
31. 1 Adaptor cable IL 5F – IL 2M, 80 cm long
32. 1 Dummy connector DC 5 F
33. 1 Box spanner 8 mm
34. 1 Hexagon socket screw key 5 mm
35. 1 Spare fuse (250V~, 500mA, fast) for conductor (Deck Command Unit)
36. 1 Spare fuse (125V~, 500mA, fast) for conductor (Motor Unit)
37. 1 Operating manual
38. 1 CD-ROM **OceanLab**

TECHNICAL DATA

Underwater Unit:

Frame dimensions: 120 x 110 x 135 cm
Frame opening: 71 x 71 cm
Length of net bags: 365 cm
Standard mesh size: 300 micron

Option:

Mesh sizes: 55 – 500 micron

Net Buckets: 110 mm Ø

Pressure Sensor:

Standard: 0 – 3000 dbar
Option: 0 – 6000 dbar
Resolution: 0.1 dbar
Accuracy (0..50°C): typ. <0.1%

Weight on air:

Underwater unit: 260 kg
Net bucket array: 70 kg

Overall length:

Of the instrument, ready for operation,
from bridle to net bucket array: 770 cm

Materials:

Net frame: Stainless steel
Motor unit: Titanium
Battery housing: Titanium
Net bags: Polyamide
Plastic net buckets: PVC
Soft buckets: Polyamide

Operational depth:

Standard: 3000 m
Option: 6000 m

Data connector:

Standard: SUBCONN BH 5 M dual-purpose connector (RS232 and FSK ports). RS232 for programming and bulk data retrieval, FSK for online operation.

Counter plug (included):

Standard: SUBCONN IL 2 F (for connection to electromechanical cable, used in conjunction with adaptor cable IL 5 F – IL 2 M (included))

Deck Command Unit:

Metal housing for 19"-rack / desktop case.
Protection class (not for use on deck): IP20
Supertwist LCD display with LED backlight

Power Supply:

Underwater unit:
3 Lithium batteries: Duracell DL 123 A or equivalent; capacity sufficient for approx. 30 operations in basic configuration
Deck command unit:
Mains supply: 85..260 V~

Operation temperature:

Motor Unit: -40..+85°C
Deck command Unit: 0..+70°C

Recommended towing speed:

For net bags with 300 micron mesh size:
Horizontal collections: max. 4 knots
Vertical collections: max 1 m/sec

Cable connection:

Single or multi conductor cable, one pole may be in contact with sea water
Resistance (go- and return line): max. 1kOhm
Cable voltage: max. 5 V
Input and output short circuit proof and protected against overvoltage.

Calculated tensile load:

Towing speed: 2 kn (1.0 m/s) 360 kg
3 kn (1.5 m/s) 540 kg
4 kn (2.0 m/s) 800 kg
5 kn (2.5 m/s) 1000 kg

Important:

Add to calculated load:
weight of cable in water: in kg
for shock: 100 %
safety factor for cable: 300 %

Considering the above mentioned loads, max. 50% of the breaking load of the cable should be utilized.

The single or multi conductor cable is not included in our scope of delivery!

Offline mode:

Sampling rate: 1 Hz (1 data set per second)
Bytes per data set: 9 to 25 (depending on sensor configuration of the **MultiNet**)
Data memory: 16 Mbyte, sufficient for 180 to 500 hours of continuous recording

BATTERY CHANGE

1. Make sure that the lever switch at the outside of the Motor Unit is switched into position **O** (Fig. 2 A).
2. Unplug the cable connection between Battery Housing and Motor Unit.
3. Loosen the Battery Housing from the Motor Unit by screwing the star grip screw counter-clock wise and bring Battery Housing into a dry room.
4. Unscrew the union nut from the Battery Housing and remove pressure tube.
5. Place 3 lithium batteries DURACELL DL123A /3 V or equivalent into the battery holders. Take care of **correct polarity**. Secure all batteries with retainer covers.
6. Make sure that the sealing surface in the pressure tube is clean and uninjured. If necessary use a lint-free cloth for cleaning.

Do not use absorbent cotton!

7. Slightly grease the sealing surface in the pressure tube with O-ring lubricant.
8. Make sure that the O-ring in the flange is clean and uninjured. If necessary use a lint-free cloth for cleaning.

Do not use absorbent cotton!

9. If the O-ring is defective, use a blunt tool (e.g. ball point pen cartridge or a piece of wood) to take the O-ring out of the groove.

Take care that the groove in the flange will not be damaged!

10. Make sure that the groove in the flange is clean and uninjured. If necessary use a lint-free cloth for cleaning.

Do not use absorbent cotton!

11. Slightly grease a spare O-ring no. 120 with O-ring lubricant.
12. Put the greased O-ring into the groove of the flange.
13. Carefully press the flange into the pressure tube.
14. Fasten the flange at the pressure tube with the plastic union nut.
15. Slightly grease the pins of the underwater connectors with pin lubricant and re-establish the electric connection between Battery Housing and Motor Unit.
16. Place the Battery Housing in its seat at the Motor Unit.
17. Fix the Battery Housing at the Motor Unit with the star grip screw.

Do not use any tool!

PREPARATION OF UNDERWATER UNIT AND NET BAGS

Preparation for HORIZONTAL operation:

For HORIZONTAL operation please use the white Soft Buckets.

1. Loosen the fixing clamps of all red Plastic Net Buckets and remove all red Plastic Net Buckets and red Fixing Rings.
Tool: Box spanner 8 mm.
2. Remove all fixing clamps from the net bags.
3. Slide the boltrope ends of the Soft Buckets into the white boltrope fixing ring.
4. Slide the boltrope ends of the net bags into the white boltrope fixing ring.

Preparation for VERTICAL operation:

For VERTICAL operation please use the red Plastic Net Buckets.

1. Firstly fix a net bag (net bag no. **9**) to the hindmost (last) zip fastener of the canvas part.
2. Put the rear end of the net bag on a fixing ring of a Plastic Net Bucket and fasten it finger-tight by means of a fixing clamp (Fig. 3 A).
Tool: Box spanner 8 mm.
3. Place the plastic bolt (Fig. 3 B) of the fixing ring into tube no. **9** of the Net Bucket Holding Tube until it snaps in (Fig 3 C).
4. Repeat this procedure for the 8 remaining bags in descending order from **8** to **1**.
5. When all net bags have been fastened to the Net Bucket Holding Tube the net bags are stretched by pulling at the Net Bucket Holding Tube (Fig. 3 C).
6. Make sure the net bags are not twisted, otherwise the end of the net bag must be turned by hand until the seam of the net bag runs straight from canvas part to net bucket.
7. Fasten all 9 fixing clamps tightly (Fig. 3 A).
Tool: Box spanner 8 mm.
8. Fix a plastic Net Bucket to the fixing ring of net bag no. **1** by means of the overcentre fasteners (Fig. 3 D + E).
9. The net bucket can be marked with figure **1** by means of a felt tip pen if required.
10. Repeat this procedure for net bags **2** to **9**.
11. Place the complete Net Bucket Holding Tube on the centre bolt of the Net Bucket Array until it snaps in (Fig. 3 C + F).

OPERATING MODES (online or offline mode)

Selection of the operating mode is made **before switching on the motor unit** by connecting the deck command unit via adaptor cable IL5F -> IL2M to the BH5M connector of the motor unit to operate the **MultiNet** in ONLINE MODE for ONLINE OPERATION (wiring according to page 42.1)

- or -

By connecting the PC via programming cable IL5F -> Sub-D 9 pin directly to the BH5M connector of the motor unit to prepare an OFFLINE OPERATION (wiring according to page 42.3) resp. to transfer stored data from the motor unit to the PC after an offline operation

- or -

the dummy connector DC5F directly to the motor unit to carry out an OFFLINE OPERATION according to the pre-programmed activation pressures.

The **MultiNet automatically** starts an OFFLINE OPERATION when switched on if neither adaptor cable IL5F -> IL2M nor programming cable is connected and thus creates a new data file in internal memory.

Recorded data of previous offline operations will not be deleted. The **MultiNet** will stop recording automatically when the internal data memory is completely used.

Important note: Automatic data recording will only take place in offline mode! To log / record data while operating online a PC running **OceanLab** can be connected to the Deck Command Unit via RS232.

Online operation can be performed via RS232 if suitable signal converting equipment is installed at both ends of the electrical cable. In this case the PC running **OceanLab** can be connected directly to the signal converting equipment using the programming cable. A special cable from the underwater part of the signal converting equipment to the motor unit is required.

WIRING FOR ONLINE OPERATION

1. The connection between Deck Command Unit and Underwater Unit is made by a single or multi conductor cable in conjunction with the supplied adaptor cable IL 5 F – IL 2 M. The single- or multi conductor cable is not included in our scope of delivery. For cable specification see TECHNICAL DATA, page 5.
2. Using a single conductor cable (one isolated core and one outer steel armour) the isolated core of the cable has to be connected to the white core of pin 2 (data) of the supplied counter plug SUBCONN IL 2 F (Fig. 1 A). The outer steel armour of the cable has to be connected to the black core of pin 1 (ground).
3. Using a multi conductor cable (two or more isolated cores) any two cores of this cable have to be connected to the white (data) and the black (ground) core of the supplied counter plug SUBCONN IL 2 F (Fig. 1 A).
4. When an existing single or multi conductor cable is already equipped with an underwater connector, the supplied connector SUBCONN IL 2 F (Fig.1 A) has to be combined with a counter plug (corresponding to the existing connector) to a cable adaptor.
5. The connection from the ship side end of the single or multi conductor cable at the winch drum (via slip rings of the winch) to the Deck Command Unit has to be made by using the supplied connecting cable (Fig. 1 C):
The core of the single or multi conductor cable coupled to pin 1 (ground) of the plug SUBCONN IL 2 F (Fig. 1 A) has to be connected to the brown core of the connecting cable (Fig. 1 C). The core coupled to pin 2 (data) of the plug SUBCONN IL 2 F has to be connected to the blue core of the connecting cable.
6. To avoid corrosion at the contacts of the connector SUBCONN IL 2 F (Fig. 1 A) the contacts should be slightly greased with pin lubricant and always be protected by the dummy DC 2 M (Fig. 1 B) when the single or multi conductor cable is not used.
7. Install Deck Command Unit in a dry room. The use on deck is not allowed.
8. Bring main switch into position "0" (Fig. 4B).
9. Connect mains cable to the socket located at the rear side of the deck command unit (Fig. 4A).
10. Connect mains cable to mains supply (85..260V~).

THE CONNECTION OF THE UNDERWATER CONNECTOR TO THE SINGLE OR MULTI CONDUCTOR CABLE HAS TO BE MADE WITH GREATEST CARE!

MOST MALFUNCTIONS ARE CAUSED BY CABLE CONNECTION FAULTS!

DECK COMMAND UNIT: COMPONENTS AND MAIN SCREEN

The Deck Command Unit is equipped with the following components:

1. Socket for mains cable, located at the rear side (Fig. 4 A).
2. Mains fuse (2 A slow), integrated in the socket for the mains cable (Fig. 4 A)
3. Main switch **POWER**, illuminated (Fig. 4 B).
4. Socket **UNDERWATER UNIT** to connect the Underwater Unit via test run cable resp. single or multi conductor cable (Fig. 4 C).
5. Socket **PERSONAL COMPUTER SERIAL PORT** to connect a personal computer (Fig. 4 D).
6. Button **ACTION** to activate the net bags (Fig. 4 E).
7. Keyboard **MENU + - ENTER** for menu control (Fig. 4 F).
8. Alphanumeric display (four lines, 40 characters each) with backlight (Fig. 4 G).
9. Set screw **CONTRAST** to adjust the contrast of the display at the rear side of the housing.
10. Fuse (250V AC / 0.5 A / fast) for **CONDUCTOR** at the rear side of the housing.

MAIN SCREEN:

The main screen is displayed after switching on Deck Command Unit and Underwater Unit when a valid electrical connection has been established.

```
MULTI PLANKTON SAMPLER 9nets / 3000m
      UNDERWATER UNIT: MOTOR RUNS
PRESS 1400.3 dbar NET 3 BATT 9.6 V
FLOW 00300 m3 in 0.7 m/s out 0.7 m/s
```

First line:

MULTI PLANKTON SAMPLER 9nets / 3000m type of instrument connected,
incl. the depth range of the instrument.

To avoid damages do not exceed the maximum operational depth range of the instrument!

Second line:

UNDERWATER UNIT: MOTOR RUNS during changing the net bags.
UNDERWATER UNIT: END OF OPERATION when the last net bag has been closed.

In addition the second line is used to display ERROR MESSAGES, if any (see page 11).

Third line:

PRESS 1400.3 dbar actual pressure value of the integrated Pressure Sensor.

NET 3 number of active net bag.

BATT 9.6 V battery voltage of the Underwater Unit.

Notice: Batteries should be changed when battery voltage falls below 7 V whilst the motor is not running. When the battery voltage falls below 1.5 V the Motor Unit is switched off automatically. A restart requires a new set of batteries.

Fourth line:

FLOW 00300 m³ filtered water volume of the active net bag.

in 0.7 m/s actual water speed inside the opening of the Underwater Unit.

out 0.7 m/s actual water speed beside the opening of the Underwater Unit.

The maximum speed to be detected by the Flowmeters is 9.9 metres per second.

DECK COMMAND UNIT: ERROR MESSAGES AND MENU SCREEN

ERROR MESSAGES:

The following error messages are displayed in the **second line** of the display only:

UNDERWATER UNIT: NO DATA no data received from the Underwater Unit:

The Motor Unit is switched off or not connected, or the batteries of the Motor Unit are exhausted, or the cable connection between Deck Command Unit and Motor Unit is interrupted.

UNDERWATER UNIT: INVALID DATA data received from the Underwater Unit are invalid:

The connected Motor Unit is not compatible with the Deck Command Unit.

SINGLE CONDUCTOR CABLE: SHORT CIRCUIT short circuit detected in the cable connection between Deck Command Unit and Motor Unit.

MENU SCREEN:

The menu screen is displayed upon pressing button **MENU** (Fig. 4 F):

MENU	> QUIT MENU
	MANUAL MOTOR CONTROL
SELECT: +/-	RESET NET NUMBER
START: ENTER	RESET PRESSURE SENSOR

Left column:

MENU Indication for main menu.

SELECT: +/- Selection of menu items is made by using the buttons **+** and **-**.
Pressing button **+** moves the marker **>** one line down,
Pressing button **-** moves the marker **>** one line up.

START: ENTER Press button **ENTER** to enter the selected menu item.

Right column:

QUIT MENU to quit menu screen and to return to main screen.

MANUAL MOTOR CONTROL (accessible with Motor Unit connected only) to start a short motor run (1/2 revolution of the motor axle) and to set the net number to 0, used to synchronize Motor Unit with Deck Command Unit.

RESET NETNUMBER (accessible with Motor Unit connected only) to set the net number to 0, used to synchronize Motor Unit with Deck Command Unit.

RESET PRESSURE SENSOR (accessible with Motor Unit connected only) to recalibrate the Pressure Sensor. Use menu item whilst Underwater Unit stands on deck at temperatures from +5°C to +35°C only.

DECK COMMAND UNIT: QUIT MENU AND MANUAL MOTOR CONTROL

MENU ITEM: QUIT MENU:

To quit menu screen and to return to the main screen activate menu item **QUIT MENU**.

MENU ITEM: MANUAL MOTOR CONTROL:

<p>MANUAL MOTOR CONTROL START MOTOR: PRESS ENTER MOTOR TURNS QUIT: MENU</p>

MANUAL MOTOR CONTROL

Indication of menu item.

START MOTOR: PRESS ENTER

To start a short motor run (1/2 revolution of the motor axle) press button **ENTER**.

MOTOR TURNS

will be displayed for approx. 1.5 second after pressing button **ENTER** as indication that the motor is active.

QUIT: MENU

To quit menu item (without or after carrying out a short motor run) and to return to menu screen press **MENU**.

DECK COMMAND UNIT: RESET NETNUMBER AND RESET PRESSURE

MENU ITEM: RESET NETNUMBER:

```
RESET NETNUMBER
  SET NUMBER TO ZERO: PRESS ENTER
  NET = 0
QUIT: MENU
```

RESET NETNUMBER Indication of menu item.

SET NUMBER TO ZERO: PRESS ENTER To reset the netnumber press button **ENTER**.

NET = 0 will be displayed after pressing button **ENTER** as indication that the reset has been carried out successfully.

QUIT: MENU To quit menu item (without or after resetting the netnumber) and to return to menu screen press **MENU**.

MENU ITEM RESET PRESSURE SENSOR:

```
RESET PRESSURE SENSOR
  SET PRESSURE TO ZERO: PRESS ENTER
  PRESSURE = 0000.0 dbar
QUIT: MENU
```

RESET PRESSURE SENSOR Indication of menu item.

SET PRESSURE TO ZERO: PRESS ENTER To recalibrate the Pressure Sensor press **ENTER**.

Use menu item whilst Underwater Unit stands on deck at Temperatures from +5°C to +35°C and has reached surrounding temperature only.

The recalibration is irreversible!

PRESSURE = 0000.0 dbar Return signal from the Underwater Unit after pressing **ENTER**.

QUIT: MENU To quit menu item (without or after resetting the Pressure Sensor) and to return to menu screen press **MENU**.

FIRST TEST RUN

In order to check the function of Deck Command Unit and Underwater Unit the following steps have to be carried out:

TO AVOID DANGER FOR THE OPERATORS CAUSED BY FREE FALLING LEVER ARMS THE SPRINGS FOR OPENING / CLOSING THE NET BAGS MUST NOT BE STRETCHED!

1. The Deck Command Unit has to be switched off. The main switch is not illuminated (Fig. 4 B).
2. The lever switch at the Motor Unit has to be switched into position **O** (Fig. 2 A).
3. Dismount the right angular guide plate of the Underwater Unit (Fig. 5 E).
Tool: Hexagon socket screw key 5 mm
4. Remove dummy SUBCONN DC 5 F.
5. Slightly grease the contacts of the connector SUBCONN BH 5 M with pin lubricant (Fig. 2 B).
6. Connect the test run cable to the Deck Command Unit (Fig. 1 D, Fig. 4 C).
7. Connect the test run cable to the connector SUBCONN BH 5 M at the Motor Unit (Fig. 2 B).
8. Switch on the Deck Command Unit, the main switch is illuminated (Fig. 4 B), the display indicates:
UNDERWATER UNIT: NO DATA
9. Switch the lever switch at the Motor Unit into position **I** (Fig. 2 A), the Deck Command Unit displays the MAIN SCREEN (see DECK COMMAND UNIT, page 10).
10. Press button **ACTION** at the Deck Command Unit (Fig. 4 E) to activate the first net bag.
The second line of the display indicates:
UNDERWATER UNIT: MOTOR RUNS
The net number is updated after approx. 2 seconds:
NET 1
After another second the motor run is completed, the text in the second line of the display disappears.
11. Repeat item 10. for another 9 times to finish the simulation of a complete operation. The last motor run (whilst closing net bag no. **9**) takes approx. 9 seconds. The second line of the display indicates:
UNDERWATER UNIT: END OF OPERATION
12. Switch lever switch at the Motor Unit into position **O** (Fig. 2 A).
13. Switch off the Deck Command Unit (Fig. 4 B).
14. Remove the test run cable from Deck Command Unit and Motor Unit (Fig. 1 D).
15. To avoid corrosion at the contacts of the connector SUBCONN BH 5 M (Fig. 2 B) the contacts should be slightly greased with pin lubricant and always be protected by the dummy connector DC 5 F when no single or multi conductor cable is connected.
16. Remount the angular guide plate (Fig. 5 E).

SECOND TEST RUN

In order to check the function of Deck Command Unit and Underwater Unit in combination with winch and single or multi conductor cable the following steps have to be carried out:

TO AVOID DANGER FOR THE OPERATORS CAUSED BY FREE FALLING LEVER ARMS THE SPRINGS FOR OPENING / CLOSING THE NET BAGS MUST NOT BE STRETCHED!

1. Switch off the Deck Command Unit, the main switch is not illuminated (Fig. 4 B).
2. Switch lever switch at the Motor Unit into position **O** (Fig. 2 A).
3. Remove dummy SUBCONN DC 5 F from the Motor Unit.
4. Connect adaptor cable IL 5 F – IL 2 M to the connector SUBCONN BH 5 M on the Motor Unit.
5. Connect single or multi conductor cable with its connector IL 2 F to adaptor cable on the Motor Unit
6. Connect the electrical cable from the winch to the Deck Command Unit, using the supplied connecting cable (Fig. 1 C, Fig. 4 C).
7. Switch on the Deck Command Unit, the main switch is illuminated (Fig. 4 B), the display indicates:
UNDERWATER UNIT: NO DATA
8. Switch the lever switch at the Motor Unit into position **I** (Fig. 2 A), the Deck Command Unit shows the MAIN SCREEN (see DECK COMMAND UNIT, page 10).
9. Confirm net number (in 3rd line of display) reads **NET 0**
10. Confirm marking pins on the steering cylinder and gearbox are aligned.
11. Press button **ACTION** (Fig. 4 E) to activate the first net bag.
The second line of the display indicates:
UNDERWATER UNIT: MOTOR RUNS
The netnumber is updated after approx. 2 seconds:
NET 1
After another seconds the motor run is completed, the text in the second line disappears.
12. Repeat item 11. for another 9 times to finish the simulation of a complete operation. The last motor run (whilst closing net bag no. **9**) takes approx. 9 seconds. The second line of the display indicates:
UNDERWATER UNIT: END OF OPERATION
13. Marking pins on steering cylinder and gear box are again aligned.
14. Switch lever switch at the motor unit into position **O** (Fig. 2 A).
15. Switch off the Deck Command Unit (Fig. 4 B).
16. Remove single or multi conductor cable and adaptor cable.
17. To avoid corrosion at the contacts of the connector SUBCONN BH 5 M (Fig. 2 B) the contacts should be slightly greased with pin lubricant and always be protected by the dummy DC 5 F when no single or multi conductor cable is connected.
18. To avoid corrosion at the contacts of the connector SUBCONN IL 2 F (Fig. 1 A) the contacts should be slightly greased with pin lubricant and always be protected by the dummy DC 2 M (Fig. 1 B) when the single or multi conductor cable is not used.
19. Remount the angular guide plate (Fig. 5 E).

OFFLINE OPERATION

1. To prepare for **OFFLINE OPERATION** connect the programming cable IL 5 F --> Sub-D 9 pin to the connector BH 5 M of the Motor Unit before switching it on.
2. Connect the programming cable to the serial COM-port of the PC.
3. Switch on the Motor Unit.
4. Start **OceanLab**.
5. Establish a connection to the **MultiNet** by clicking the Connect button in **OceanLab**.
6. Carry out a PC-CONTROLLED TEST RUN by controlling the **MultiNet** from the **CONTROLLING MODE** of the data acquisition software **OceanLab** (see MANUAL of **OceanLab**).

While conducting the test run the springs for opening / closing the net bags must NOT be stretched!

During the test run observe the battery voltage inside the **CONTROLLING MODE** of **OceanLab**. The batteries of the Motor Unit should be changed when the battery voltage falls below 7 V whilst the motor of the Motor Unit is active.

- Confirm Motorposition and Net (in the leftmost tab) read "0" (zero).
 - Confirm marking pins on the steering cylinder and gearbox are aligned.
 - Click either Action button (within the Net component or next to the net number display on the leftmost tab). The motor will run, revolving the steering cylinder. After approx. 3 seconds the motor will stop, the readings in Motorposition and Net within **OceanLab** will update, reading "1".
 - Repeat this 9 times, Motorposition and Net will read "10". (The run from "9" to "10" will last for approx. 9 seconds.)
 - Marking pins on the steering cylinder and gearbox are again aligned.
7. To reset the **MultiNet** after the Test Run switch off the motor unit, and switch it on again after 2 – 3 seconds. The Net Number resp. Motorposition will read zero. The **MultiNet** is now ready for programming.
 8. Select **MEMORY** from the list of components and make sure that the remaining capacity of data memory is sufficient for the next operation.
 9. When the remaining capacity seems barely sufficient click on button **CLEAR MEMORY** to clear the data memory of the Motor Unit.

THIS FUNCTION IS IRREVERSIBLE!

Please note that the MultiNet automatically starts an OFFLINE-OPERATION when switched on with neither adaptor cable IL 5 F --> IL 2 M nor programming cable connected and thus creates a new data file inside the data memory! The measuring data of a previous OFFLINE-OPERATION will not be deleted. The MultiNet will stop recording measuring data automatically when the data memory is completely used.

10. Select **PRESSURE PROGRAMMING** from the list of implements to get access to the list of programmable activating pressures.
11. Enter the **UNLOCK PRESSURE** in the format:
nnnn.n (nnnn.n: pressure in dbar)

The Motor Unit will be disabled during lowering the **MultiNet** into the water until reaching the **UNLOCK PRESSURE** (but will continuously record measuring data). Thus the **UNLOCK PRESSURE** should be at least. 5 dbar greater than the opening pressure of the first net bag.

-
12. Enter a list of **NET CHANGING PRESSURES** in the format:
mmmm.m (mmmm.m: pressure in dbar)

The **NET CHANGING PRESSURES** must be in **descending** order. That means that the first net bag will be opened in the greatest scheduled depth. The pressure for the first net bag **must** be smaller than the **UNLOCK PRESSURE**.

13. Click on button **SEND TO INSTRUMENT** to transfer the activating events to the Motor Unit.
14. Switch off the Motor Unit.
15. Remove the programming cable (IL 5 F --> Sub-D 9 pin) from the Motor Unit.
16. Slightly grease the pins of the connector SUBCONN BH 5 M at the Motor Unit with pin lubricant.
17. Place the dummy SUBCONN DC 5 F on the connector SUBCONN BH 5 M at the Motor Unit and secure it with its locking sleeve.
18. Remount the angular guide plate (Fig. 5 E).

PREPARATION FOR HORIZONTAL COLLECTIONS IN ONLINE MODE

For **HORIZONTAL** operations use the **white Soft Buckets** (according to PREPARATION OF UNDERWATER UNIT AND NET BAGS, page 7) in conjunction with triangle rope and sea anchor (drogue). Net Bucket Holding Tube (Fig. 3 C) and Net Bucket Array (Fig. 3 F) are not used for horizontal operations and remain on deck.

1. The two end eyes of the first bridle are fastened with shackles to the first borings of the upper towing rails (Fig. 5 A).
2. The center eye of the bridle (Fig. 5 B) is fastened with a shackle to the towing rope (single or multi conductor cable).
3. The two end eyes of the second bridle are attached with shackles to the second borings of the lower hole rails (Fig. 5 C).
4. The centre eye of the second bridle is fastened to the revolving swivel of the depressor.
5. The revolving swivel is fastened to the third boring of the depressor (Fig. 5 D).
6. The electrical cable of the single or multi conductor cable has to be fixed to one of the lines of the upper bridle by cable ties, tape or strings.
7. Slightly grease the pins of the connector SUBCONN BH 5 M on the Motor Unit (Fig. 2 B) with pin lubricant and connect it to the adaptor cable IL 5 F – IL 2 M.
8. Slightly grease the pins of the adaptor cable and connect it to the IL 2 F connector of your electrical cable.
9. The sea-anchor (drogue) is attached to the end eye of the long leg of the triangle rope with a shackle.
10. The two end eyes of the short legs of the triangle rope are fastened with shackles to the last (hindmost) borings of the upper towing rail.

Depending on length of rope, towing speed and mesh size of the net bags the mouth of the Underwater Unit can deviate from the vertical position. The various borings in the towing rail (Fig. 5 A) allow the adjustment of the vertical position by fastening the bridles to a different boring. In addition it can be helpful to vary the attachment points at the lower hole rails and the depressor (Fig. 5 C - D). The ideal attachment points of the bridles and the depressor should be found by towing tests at the water surface.

PREPARATION FOR VERTICAL COLLECTIONS IN ONLINE MODE

For **VERTICAL** operations use the **red Plastic Net Buckets** (according to PREPARATION OF UNDERWATER UNIT AND NET BAGS, page 7) in conjunction with Net Bucket Holding Tube (Fig. 3 C) and Net Bucket Array (Fig. 3 F). Triangle rope and sea anchor (drogue) are not used for vertical operations and remain on deck.

1. The two end eyes of the first bridle are fastened with shackles to the first borings of the upper towing rail (Fig. 6 A).
2. The two end eyes of the second bridle are fastened with shackles to the first borings of the lower hole rails (Fig. 6 B).
3. Both center eyes of the bridles are fastened with a shackle to the heaving / towing rope (single or multi conductor cable) (Fig. 6 C).
4. The electrical cable of the single or multi conductor cable has to be fixed to one of the lines of the upper bridle by cable ties, tape or strings.
5. Slightly grease the pins of the connector SUBCONN BH 5 M on the Motor Unit (Fig. 2 B) with pin lubricant and connect it to the adaptor cable IL 5 F – IL 2 M.
6. Slightly grease the pins of the adaptor cable and connect it to the IL 2 F connector of your electrical cable.
7. Plug the Net Bucket Holding Tube onto the center pin of the Net Bucket Array until snap in (Fig. 3 C - F).
8. According to Fig. 3 G + H attach the 4 bucket ropes with shackles to Underwater Unit and Net Bucket Array.
9. The lengths of the bucket ropes can be adjusted with the adjusting devices (Fig. 3 J), so that the weight of the Net Bucket Array is carried by the bucket ropes and **not** by the net bags. On the other hand the bucket ropes should not be so short that the net bags have folds and thus the collected material cannot flow freely into the net buckets.
10. Attach the two handling ropes (14 mm dia.) parallel to two bucket ropes to Underwater Unit and Net Bucket Array for a secure handling of the Underwater Unit during deployment and recovery.

STRETCHING OF THE SPRINGS OF THE NET CLOSING DEVICE

1. Before stretching is started make sure that the marking pins on the steering cylinder and the gearbox are aligned (Fig. 7 A). In the affirmative continue with 9., otherwise:
 2. Switch on the Deck Command Unit, the main switch is illuminated (Fig. 4 B), the display indicates:
UNDERWATER UNIT: NO DATA
 3. Turn lever switch at the Motor Unit into position **I** (Fig. 2 A), the MAIN SCREEN appears at the display (see DECK COMMAND UNIT, page 10).
 4. Press button **ACTION**, the steering cylinder moves to the next position (Fig. 4 E, Fig. 7 D).
 5. Repeat this procedure until both marks on steering cylinder and gearbox are aligned (Fig. 7 A).
 6. The display indicates:
**UNDERWATER UNIT: END OF OPERATION
NET 10**
 7. Turn the lever switch at the Motor Unit into position **O** (Fig. 2 A).
 8. Switch off the Deck Command Unit, the main switch is not illuminated (Fig. 4 B).
 9. Turn the safety locking bar into position **A**: Pull the red ball handle into the direction of net mouth, turn it downwards and push it backwards again (Fig. 8 A).
 10. Stick the tension lever onto lever arm no. **10** and turn lever arm from pos. **D** to pos. **E** until the hook of the lever arm snaps behind the roll into the boring of the key no. **10** (Fig. 7, Fig. 8 C). During that a second person should pull the net bags backwards and take care that no net collar or net bag is pinched in the array by the net changing mechanism.
 11. Repeat this procedure for the lever arms no. **9** to no. **1**.
 12. As soon as all 10 lever arms are stretched, **immediately** turn the safety locking bar from position **A** to position **B** to avoid free fall of the stretched lever arms and thus to make sure that no lever arm can hurt persons working on the Underwater Unit (Fig. 8 F).
 13. The safety locking bar is only released just before heaving the Underwater Unit overboard.
- Even when an operation shall be carried out with less than 9 net bags, **all 9 net bags must be mounted, all 10 springs of the net closing device must be stretched** to avoid jamming of the canvas part at the lever arms inside the frame. After the operation **immediately** turn the safety locking bar from position **A** to position **B** (Fig. 8).

RELEASING OF THE SPRINGS OF THE NET CLOSING DEVICE

When the Underwater Unit is not to be deployed after STRETCHING OF THE SPRINGS OF THE NET CLOSING DEVICE, the following steps have to be carried out to release the springs of the net closing device:

IN ANY CASE A FREE FALL OF THE LEVER ARMS MUST BE AVOIDED!

1. Switch off Deck Command Unit (Fig. 4 B).
2. Switch lever switch at the Motor Unit into position **O** (Fig. 2 A).
3. Stick tension lever onto lever arm no. **1** and hold it by hand in vertical position (Fig. 8 C).
4. Turn safety locking bar into position **A**, all lever arms are unlocked now (Fig. 8).
5. Lift key no. **1** with one hand, so that the catch at lever arm no. **1** is released (Fig. 7 B).
6. Turn tension lever **slowly** from position **E** into position **D** (Fig. 8). During that a second person should pull the net bags backwards and take care that no net collar or net bag is pinched in the array by the net changing mechanism.
7. Repeat this procedure for lever arms no. **2** to no. **10**.

If the safety locking bar has not been unlocked before operation and the net bags have been actuated by Deck Command Unit, all 10 spring loaded lever arms are pressing at the safety hooks (Fig. 8 F).

DUE TO SECURITY REASONS DO NOT TURN THE SAFETY LOCKING BAR INTO ANOTHER POSITION!

The following steps are necessary to bring the net closing device into a correct position again:

1. Make sure that the Motor Unit is switched off (Fig. 2 A).
2. Make sure that the Deck Command Unit is switched off (Fig. 4 B).
3. Stick tension lever onto lever arm no. **10** (Fig. 8).
4. Turn tension lever upwards into position **E** until the hook at lever arm no. **10** snaps behind the roll into the boring of key no. **10** (Fig. 7 B).
5. Repeat this procedure for lever arms no. **9** to no. **1**.
6. The safety locking bar remains in position **B** (Fig. 8), the Underwater Unit is ready for the next operation.
7. When no operation shall be carried out, the net closing device has to be released according to step 1. to step 7. above.

OPERATION IN ONLINE MODE

When the underwater connector SUBCONN IL 2 F has been recently mounted to the single or multi conductor cable, resp. a cable adaptor has been made, the Deck Command Unit should be carefully observed during the first operation whether the display continuously displays the MAIN SCREEN (see DECK COMMAND UNIT, page 10).

In case of the message **UNDERWATER UNIT: NO DATA** the cable connection between Deck Command Unit and Underwater Unit is interrupted. In case of the message **SINGLE CONDUCTOR CABLE: SHORT CIRCUIT** a short circuit has been detected in the cable connection between Deck Command Unit and Underwater Unit. To localize and remove the faults occurred, follow the instructions according to LOCALIZATION OF FAULTS, page 31.

1. When the **MultiNet** has not been operated for a longer period it is advisable to carry out a SECOND TEST RUN (page 15).
2. Just before deployment the **MultiNet** is started by setting the lever switch at the Motor Unit into position **I** (Fig. 2 A).
3. Switch on the Deck Command Unit, the main switch is illuminated (Fig. 4 B), the display indicates the MAIN SCREEN (see page 10).
4. Turn the safety locking bar into position **A** (Fig. 8). The **MultiNet** is now ready for deployment.

Even when an operation shall be carried out with less than 9 net bags, **all 9 net bags must be mounted, all 10 springs of the net closing device must be stretched** to avoid jamming of the canvas part at the lever arms inside the frame. After the operation **immediately** turn the safety locking bar from position **A** to position **B** (Fig. 8).

For HORIZONTAL COLLECTIONS see page 24.

For VERTICAL COLLECTIONS see page 25.

OPERATION WITH LESS THAN 9 NET BAGS IN ONLINE MODE

Even when an operation shall be carried out with less than 9 net bags, **all 9 net bags must be mounted, all 10 springs of the net closing device must be stretched** to avoid jamming of the canvas part at the lever arms inside the frame.

After an operation where less than 9 net bags have been activated the following steps have to be carried out to bring the Underwater Unit into its start position:

1. Switch off the Deck Command Unit (Fig. 4 B).
2. Switch lever switch at the Motor Unit into position **O** (Fig. 2 A).
3. Stick tension lever onto the first still stretched lever arm and hold it by hand in vertical position (Fig. 8 C).
4. Unlock safety locking bar by turning it into position **A** (Fig. 8).
5. Lift the corresponding key with the second hand, so that the catch at the lever arm is released (Fig. 7 B).
6. Turn tension lever **slowly** into the horizontal position **D** (Fig. 8). During that a second person should pull the net bags backwards and take care that no net collar or net bag is pinched in the array by the net changing mechanism.
7. Repeat this procedure for the remaining lever arms in numerical order.

When all lever arms are released, the steering cylinder has to be turned into start position (Fig. 7 A):

8. Connect Deck Command Unit and Motor Unit by test run cable or single resp. multi conductor cable (Fig. 1 D, Fig. 2 B, Fig. 4 C).
9. Switch on the Deck Command Unit (Fig. 4 B), the display indicates:
UNDERWATER UNIT: NO DATA
10. Switch lever switch at the Motor Unit into position **I** (Fig. 2 A), the display indicates the MAIN SCREEN (see DECK COMMAND UNIT, page 10).
11. Press button **ACTION** (Fig. 4 E), the steering cylinder turns to its next position (Fig. 7 D).
12. Repeat this procedure until both marks on steering cylinder and gearbox are aligned (Fig. 7 A).
13. The display indicates:
**UNDERWATER UNIT: END OF OPERATION
NET 10**
14. Switch off Deck Command Unit and Underwater Unit (Fig. 2 A, Fig. 4 B).

Preparation for the next operation is made according to STRETCHING OF THE SPRINGS OF THE NET CLOSING DEVICE (page 20).

HORIZONTAL COLLECTIONS IN ONLINE MODE

For **HORIZONTAL** operations use the **white Soft Buckets** (according to PREPARATION OF UNDERWATER UNIT AND NET BAGS, page 7) in conjunction with triangle rope and sea anchor (drogue). Net Bucket Holding Tube (Fig. 3 C) and Net Bucket Array (Fig. 3 F) are not used for horizontal operations and remain on deck.

1. Lower the Underwater Unit from the slow moving vessel into the water just below the water surface. Check that the opening of the Underwater Unit has an almost vertical position (see PREPARATION FOR HORIZONTAL COLLECTIONS, page 18).
2. Lower the Underwater Unit at the intended towing speed to the greatest intended water depth.
3. Press button **ACTION** (Fig. 4 E) to open the first net bag. The display indicates **NET 1**.
4. Tow Underwater Unit with stopped winch for the desired time / distance. Thereafter heave the Underwater Unit to the next collecting depth.
5. Press button **ACTION** (Fig. 4 E) to close net no 1 and to open net no. 2; the display indicates: **NET 2**
6. Repeat steps 4. and 5. to activate the remaining net bags.
7. Net bag no. **9** has to be closed before reaching the water surface.
8. In order to wash remaining collected plankton material out of the net bags into the net buckets, the Underwater Unit should be flushed from the outside by a hose with seawater when it has been heaved out of the water but is not yet on board.
9. When the Underwater Unit is back on board switch off Motor Unit (Fig. 2 A) and Deck Command Unit (Fig. 4 B).
10. Remove the Soft Buckets from the boltrope fixing rings.

When multiple operations are planned during an expedition, the single or multi conductor cable may remain connected to the Motor Unit.

When the **MultiNet** shall not be operated for a longer period, the single or multi conductor cable has to be disconnected from the Motor Unit:

11. Disconnect single or multi conductor cable.
12. To avoid corrosion at the contacts of the connector SUBCONN BH 5 M at the Motor Unit (Fig. 2 B): Slightly grease the pins with pin lubricant and protect them by plugging the dummy SUBCONN DC 5 F onto it.
13. To avoid corrosion at the contacts of the connector SUBCONN IL 2 F (Fig. 1 A) of the single or multi conductor cable: Slightly grease the pins of the corresponding dummy SUBCONN DC 2 M (Fig. 1 B) with pin lubricant and plug it into the connector of the single or multi conductor cable.

VERTICAL COLLECTIONS IN ONLINE MODE

For **VERTICAL** operations use the **red Plastic Net Buckets** (according to PREPARATION OF UNDERWATER UNIT AND NET BAGS, page 7) in conjunction with Net Bucket Holding Tube (Fig. 3 C) and Net Bucket Array (Fig. 3 F). Triangle rope and sea anchor (drogue) are not used for vertical operations and remain on deck.

1. Stop the research vessel.
2. Lower the Underwater Unit with a speed of max. 1 m/s to the greatest intended water depth.
3. Press button **ACTION** (Fig. 4 E) to open the first net bag.
4. During heaving with a max. speed of 1 m/s the net bags are opened and closed by pressing button **ACTION** at the desired depths.
5. Net bag no. **9** has to be closed before reaching the water surface.
6. In order to wash remaining collected plankton material out of the net bags into the net buckets, the Underwater Unit should be flushed from the outside by a hose with seawater when it has been heaved out of the water but is not yet on board.
7. When the Underwater Unit is back on board switch off Motor Unit (Fig. 2 A) and Deck Command Unit (Fig. 4 B).
8. Remove the net buckets from the fixing rings.

When several operations are planned during an expedition, the single or multi conductor cable may remain connected to the Motor Unit.

When the **MultiNet** shall not be operated for a longer period, the single or multi conductor cable has to be disconnected from the Motor Unit:

9. Disconnect single or multi conductor cable.
10. To avoid corrosion at the contacts of the connector SUBCONN BH 5 M at the Motor Unit (Fig. 2 B): Slightly grease the pins with pin lubricant and protect them by plugging the dummy SUBCONN DC 5 F onto it.
11. To avoid corrosion at the contacts of the connector SUBCONN IL 2 F (Fig. 1 A) of the single or multi conductor cable: Slightly grease the pins of the corresponding dummy SUBCONN DC 2 M (Fig. 1 B) with pin lubricant and plug it into the connector of the single or multi conductor cable.

VERTICAL COLLECTIONS IN OFFLINE MODE

For **VERTICAL** operations use the **red Plastic Net Buckets** (according to PREPARATION OF UNDERWATER UNIT AND NET BAGS, page 7) in conjunction with Net Bucket Holding Tube (Fig. 3 C) and Net Bucket Array (Fig. 3 F). Triangle rope and sea anchor (drogue) are not used for vertical operations and remain on deck.

1. Stop the research vessel.
2. Lower the Underwater Unit with a speed of max. 1 m/s BELOW the pre-programmed unlocking depth.
3. Raise the Underwater Unit with a speed of max. 1 m/s. The net bags will open and close at the pre-programmed depths.
4. In order to wash remaining collected plankton material out of the net bags into the net buckets, the Underwater Unit should be flushed from the outside by a hose with seawater when it has been heaved out of the water but is not yet on board.
5. When the Underwater Unit is back on board switch off Motor Unit (Fig. 2 A) and Deck Command Unit (Fig. 4 B).
6. Remove the net buckets from the fixing rings.

OPERATION WITH LESS THAN 9 NET BAGS IN OFFLINE MODE

Even when an operation shall be carried out with less than 9 net bags, **all 9 net bags must be mounted, all 10 springs of the net closing device must be stretched** to avoid jamming of the canvas part at the lever arms inside the frame.

This leads to the fact that also **NET CHANGING PRESSURES** for unneeded net bags have to be entered into the **PRESSURE PROGRAMMING** dialog of **OceanLab**.

Make sure that the **NET CHANGING PRESSURE** for the unneeded net bags are programmed with **pressure steps of minimum 5 dbar** for each net bag.

Decide on your specific application if you activate the unneeded net bags at great depth (before reaching the intended sampling intervals) or just before reaching the water surface (after passing the intended sampling intervals).

Net bag no. 9 has to be closed before reaching the water surface.

REMOVAL OF THE CANVAS PART

(2 persons required)

1. Switch the lever switch at the Motor Unit into position **O** (Fig. 2 A).
2. Remove all net bags from the Underwater Unit.
3. Remove the bridles.
4. Place the net frame with its motor side first on the ground.
5. Place the spring hook at the tension lever into the long eye of the tension spring of lever arm no. **1** (Fig. 8 C + G).
6. With two persons extend the spring and draw it out of the eyelet of the spring rail, release the spring.
7. Take the spring out of the eyelet of lever arm no. **1**.
8. Repeat this procedure for the springs no. **2 - 10**.
9. Open the zip fasteners connecting the Canvas Part to be dismantled with the neighbouring Canvas Parts.
10. Release the overcentre fastener (located at the outside of the net frame) of the Canvas Part to be dismantled. Therefore slide the security slide of the overcentre fastener in the direction of arrow (as marked on the security slide) and lift the lever. Unhook the D-ring.
11. Loosen the fixing clamps at the corresponding lever arm.
12. Remove the canvas part from its lever arm.
13. For mounting of the canvas part see MOUNTING OF THE CANVAS PART, page 29

MOUNTING OF THE CANVAS PART

(2 persons required)

Notice: The Canvas Part of lever arm no. **1** consists of a slim pocket with only **one** zip fastener and thus is completely different from the Canvas Parts of the remaining lever arms which are equipped with **three** zip fasteners. This slim Canvas Part can only be mounted at lever arm no. **1**.

1. Slide Canvas Part with its pocket onto the corresponding lever arm.
2. Close the zip fasteners to the neighbouring Canvas Parts.
Secure closures of the zip fasteners with its touch-and-close fasteners.
3. Slide the white webbing below the fixing clamp of the corresponding lever arm. Slightly stretch the white webbing and fasten it with the fixing clamp.
4. Slide the black webbing with D-ring through the corresponding slit to the outside of the net frame. Hook D-ring into the overcentre fastener and close overcentre fastener until snap in of the security slide.
5. Make sure that the lever arm can be moved into both end positions. If it does not the tension of the Canvas Part can be adjusted with the adjusting screw inside the overcentre fastener.
6. Place one tension spring with the small eye into the eyelet of the lever arm No. **1**.
7. Place the spring hook of the tension lever into the long eye of the tension spring.
8. With two persons extend the spring and place it into the eyelet of the lower spring rail.
9. Repeat this procedure for the springs no. **2 - 10**
10. Place the net frame with its bottom side on the ground.

REMOVAL AND MOUNTING INSTRUCTIONS FOR THE MOTOR UNIT

REMOVAL

1. Remove the large angular guide plate of the Underwater Unit (Fig. 5 E).
Tool: Hexagon socket screw key 5 mm
2. Disconnect the cables for the Electronic Flowmeters from the connector SUBCONN BH 4 F (Fig. 2 D).
3. Unscrew the 3 hexagon socket screws M 6 which are located inside the gear box (Fig. 2 C).
Tool: Hexagon socket screw key 5 mm
4. Remove the Motor Unit.

MOUNTING

The **MultiNet** does only work properly when the synchronization between Motor Unit and steering cylinder has been established.

In order to re-establish the synchronization, the following steps have to be carried out:

1. Connect the test run cable to the dismantled Motor Unit (with Battery Housing connected) (Fig. 1 D, Fig. 2 B).
2. Connect the test run cable to the Deck Command Unit (Fig. 4 C).
3. Switch on the Deck Command Unit, the main switch (Fig. 4 B) is illuminated, the display indicates: **UNDERWATER UNIT: NO DATA**
4. Switch lever switch at the Motor Unit into position I (Fig. 2 A), the display indicates the MAIN SCREEN (see DECK COMMAND UNIT, page 10).
5. Press button **MENU** at the Deck Command Unit to open the MENU SCREEN.
6. Select **MANUAL MOTOR CONTROL** by pressing button **+** and enter this menu item by pressing button **ENTER**.
7. Press button **ENTER** again to start a short motor run (half revolution of the motor axle) and to set the net number to zero.
8. Return to MAIN SCREEN: Press button **MENU**, then select **QUIT MENU** and press button **ENTER** to leave the MENU SCREEN.
9. The Motor Unit is synchronized and ready for mounting. The display indicates **NET 0**. Switch lever switch at the Motor Unit into position **O** (Fig. 2 A).
10. Remove the test run cable.
11. Turn the steering cylinder by hand until the marks on steering cylinder and gear box are aligned (Fig. 7 A + D).
12. Remount the Motor Unit without distorting the position of the steering cylinder. Remount the 3 hexagon socket screws M 6 from the inside of the gear box (Fig. 2 C). Care for a small slackness between gearwheel of the Motor Unit and the gear wheels of the gear box.
13. Slightly grease the pins of the cables for the Electronic Flowmeters with pin lubricant and connect them to the connector SUBCONN BH 4 F at the Motor Unit (Fig. 2 D).
14. Carry out a FIRST TEST RUN according to page 14.

LOCALIZATION OF FAULTS

1. Upon switching on the Deck Command Unit, the main switch is not illuminated (Fig. 4 B), the display remains empty:
 - No connection to mains supply. Check connection from mains cable to Deck Command Unit and to mains socket.
 - The integrated fuse (2 A slow) of the Deck Command Unit burnt out. Change mains fuse located in the posterior partition of the drawer (spare fuse in the anterior partition) below the mains connector on rear side of the Deck Command Unit.
 - The mains socket has no voltage. Check mains socket and the cables leading to mains socket.
 - The mains cable is defective. Replace mains cable.
2. After switching on Deck Command Unit and Motor Unit the following error message appears:
UNDERWATER UNIT: NO DATA:
 - The Batteries of the Underwater Unit are exhausted. Install new batteries.
 - The electrical connection between Deck Command Unit and Motor Unit is interrupted. Localization of cable faults see below.
 - The fuses (0.5 A / fast) for the connecting cable (CONDUCTOR) in the Deck Command Unit (at rear side of housing) and in the Motor Unit (at the electronics board) burnt out. They have to be replaced.
3. After switching on Deck Command Unit and Motor Unit the following error message appears:
SINGLE CONDUCTOR CABLE: SHORT CIRCUIT:
 - The connecting cable from Deck Command Unit to winch has wrong polarity. An interchange of both pins is necessary (see WIRING FOR ONLINE OPERATION, page 9).
 - The electrical connection between Deck Command Unit and Motor Unit has a short circuit. Localization of cable faults see below.
4. After switching on Deck Command Unit and Motor Unit the following error message appears:
UNDERWATER UNIT: INVALID DATA:
 - The connected Motor Unit is not compatible with the Deck Command Unit. Connect a compatible Motor Unit.

MOST MALFUNCTIONS ARE CAUSED BY CABLE FAULTS!

The localization of cable faults is made according to the following instructions:

1. Carry out a FIRST TEST RUN (page 14) by using the test run cable (Fig. 1 D). In case of success the fault has to be located in the cable connection from Deck Command Unit to Underwater Unit.
2. Check electrical splice between the connector SUBCONN IL 2 F and the single or multi conductor cable: **90% of all cable faults are located here!**
3. Check the connection from single or multi conductor cable to the slip rings of the winch.
4. Check slip rings of the winch.
5. Check electrical connection from the winch to the Deck Command Unit.
6. After repair a SECOND TEST RUN (page 15) is applicable to check the success of the repair.

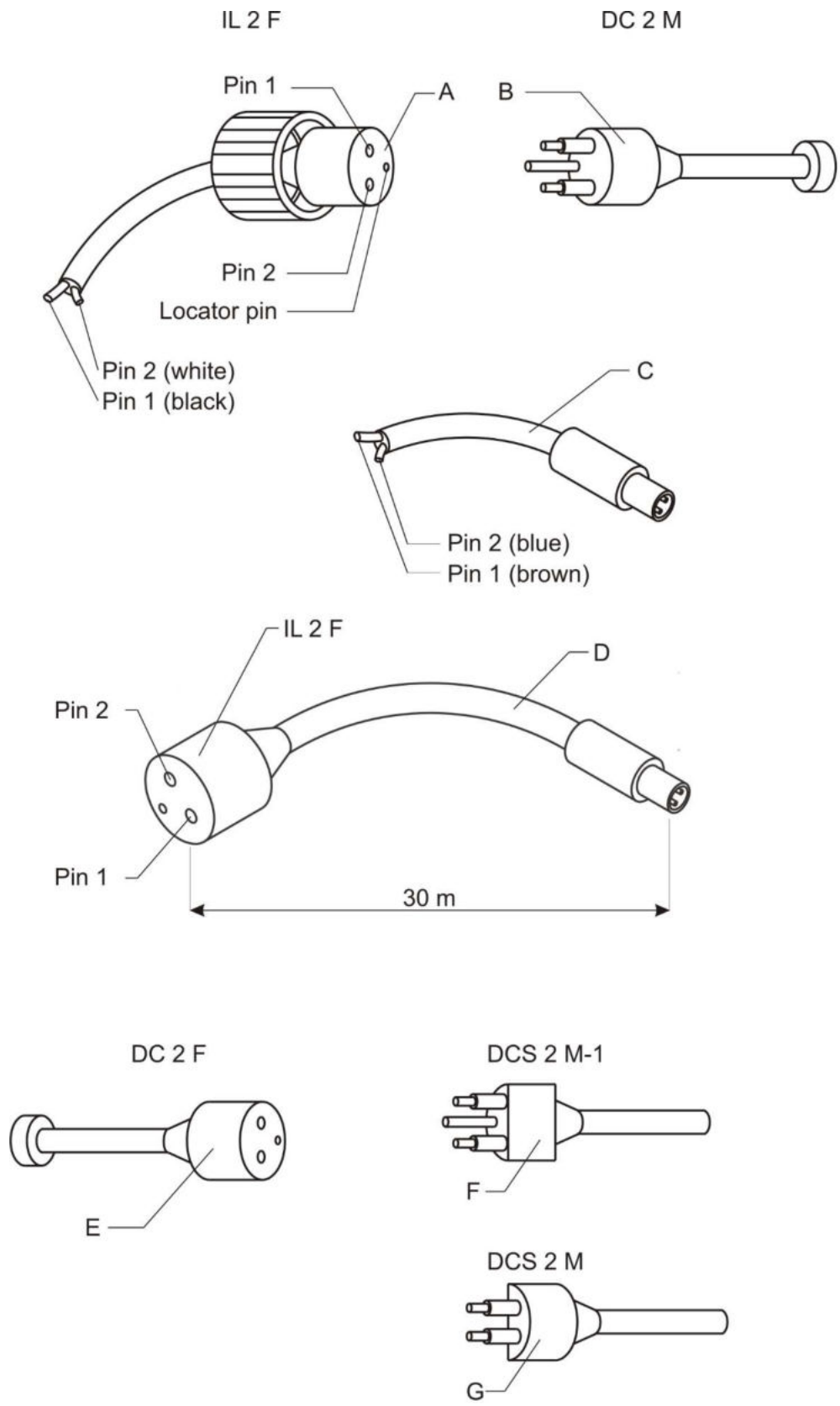

Fig 1

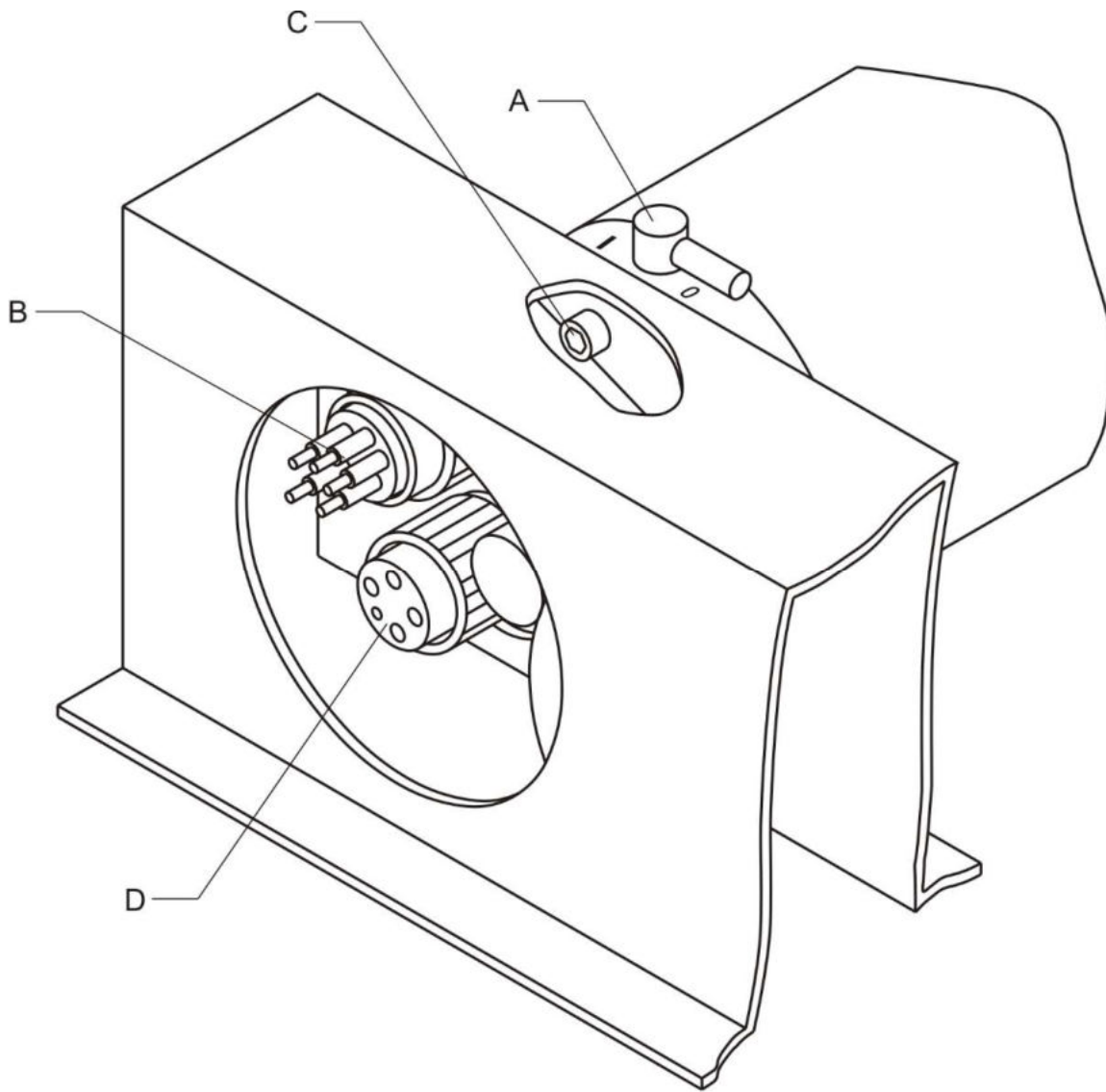

Fig 2

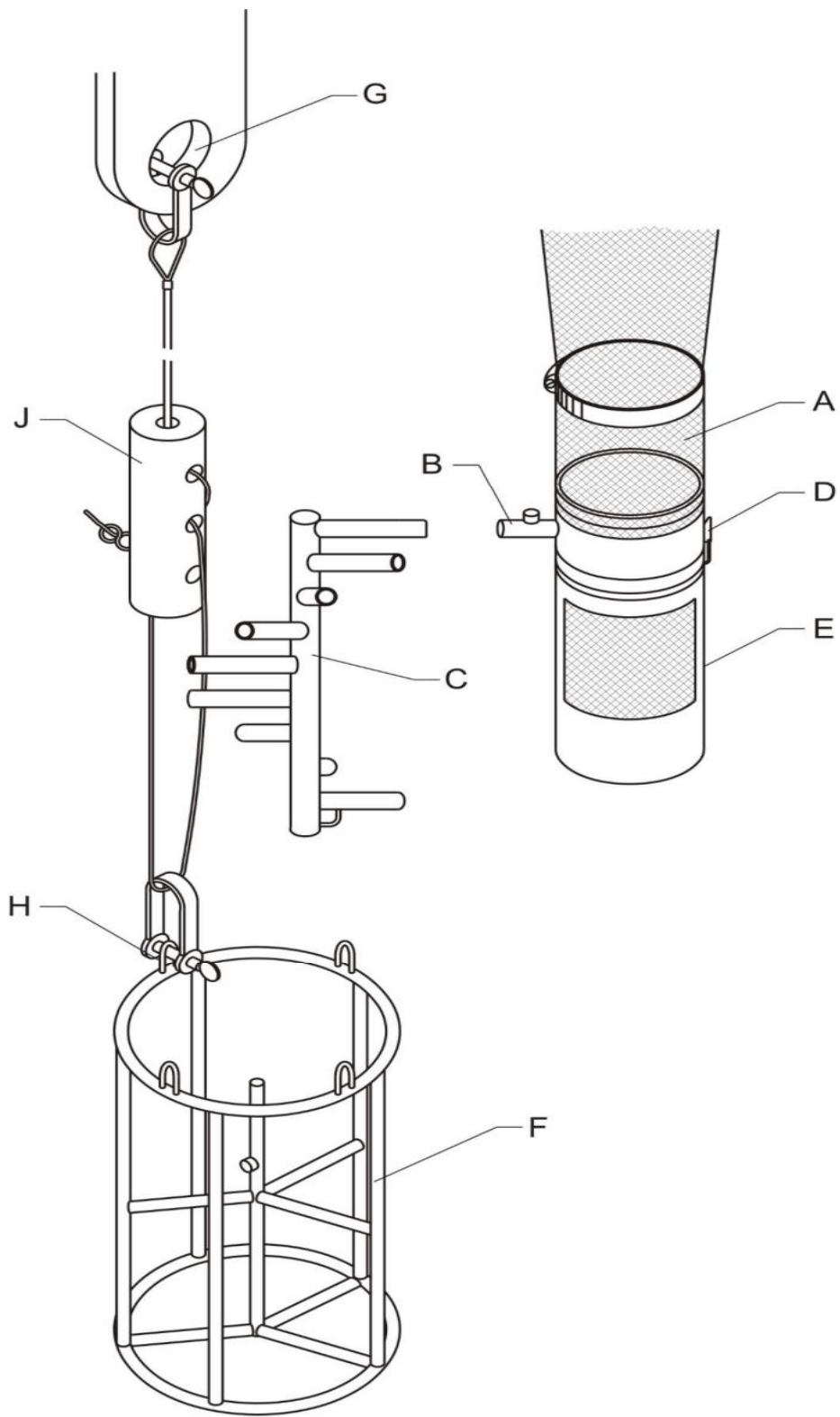

Fig. 3

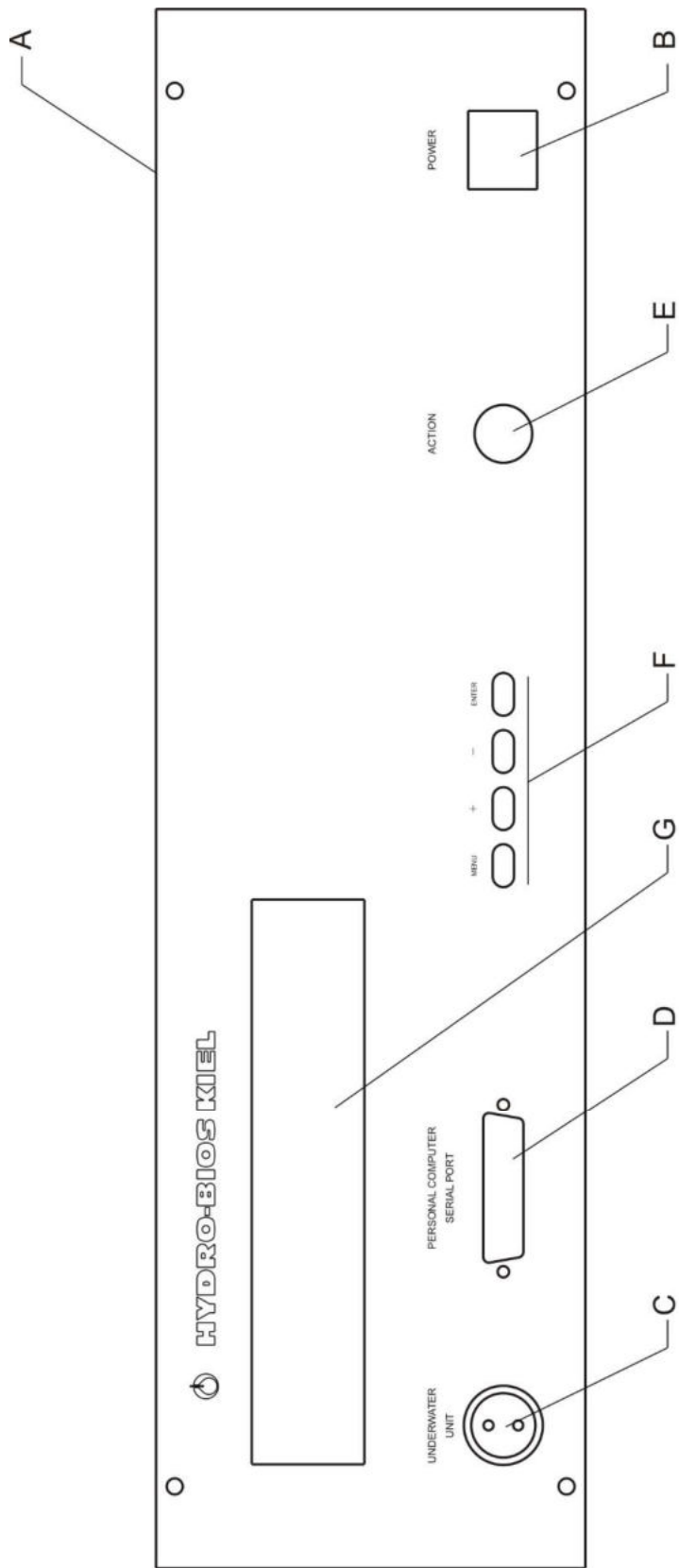

Fig. 4

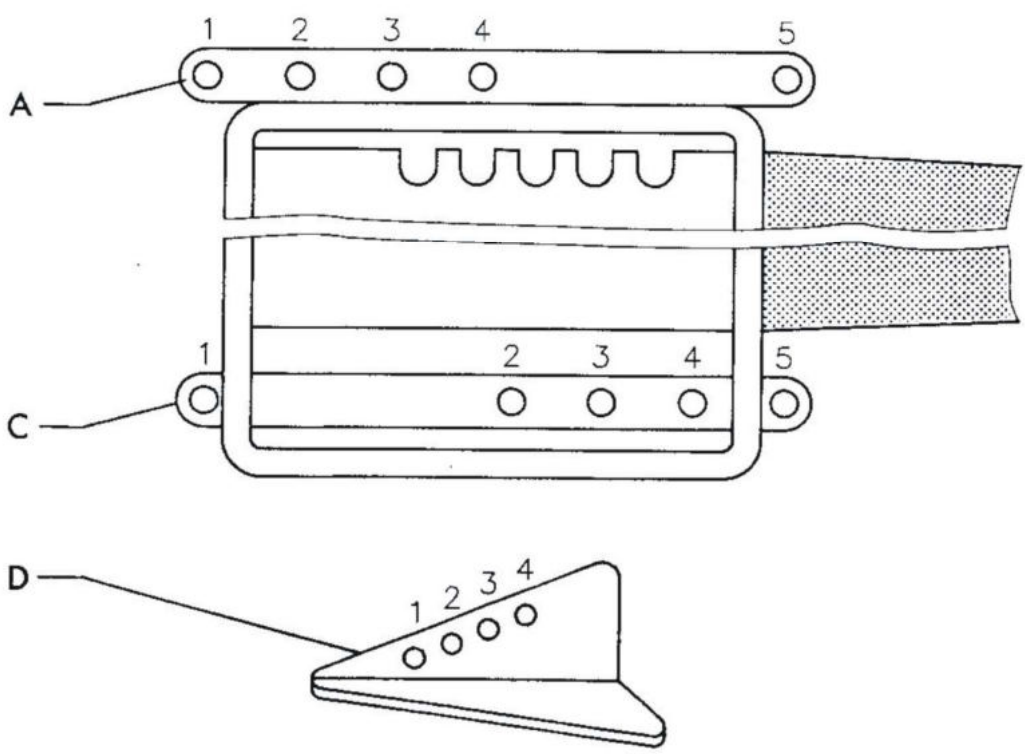
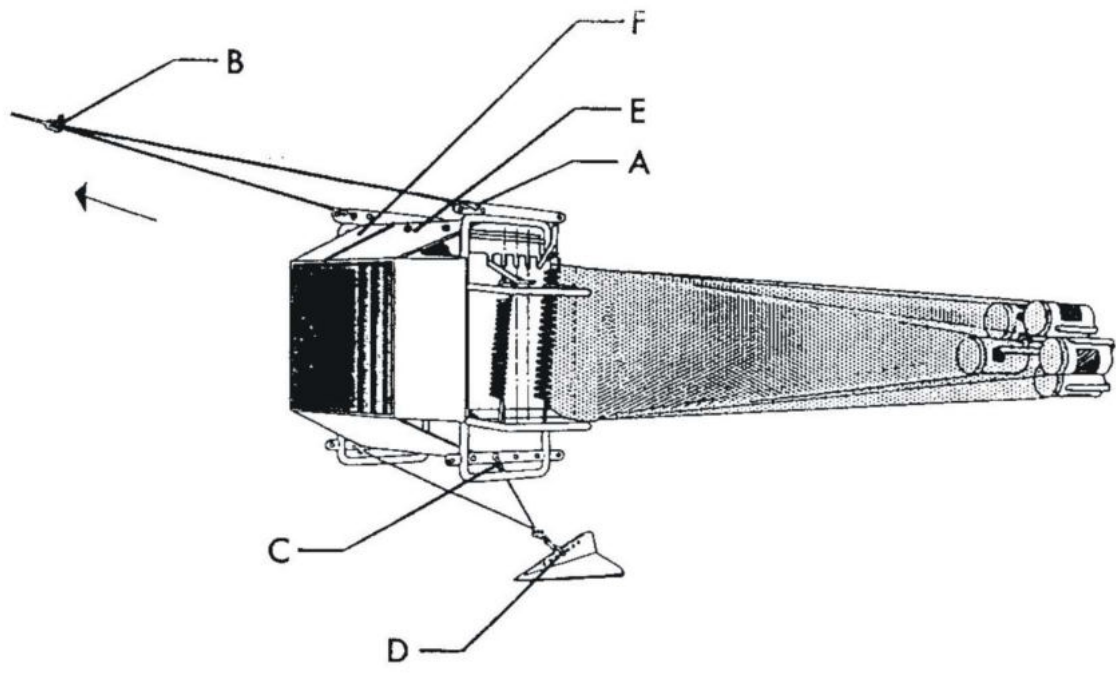

Fig. 5

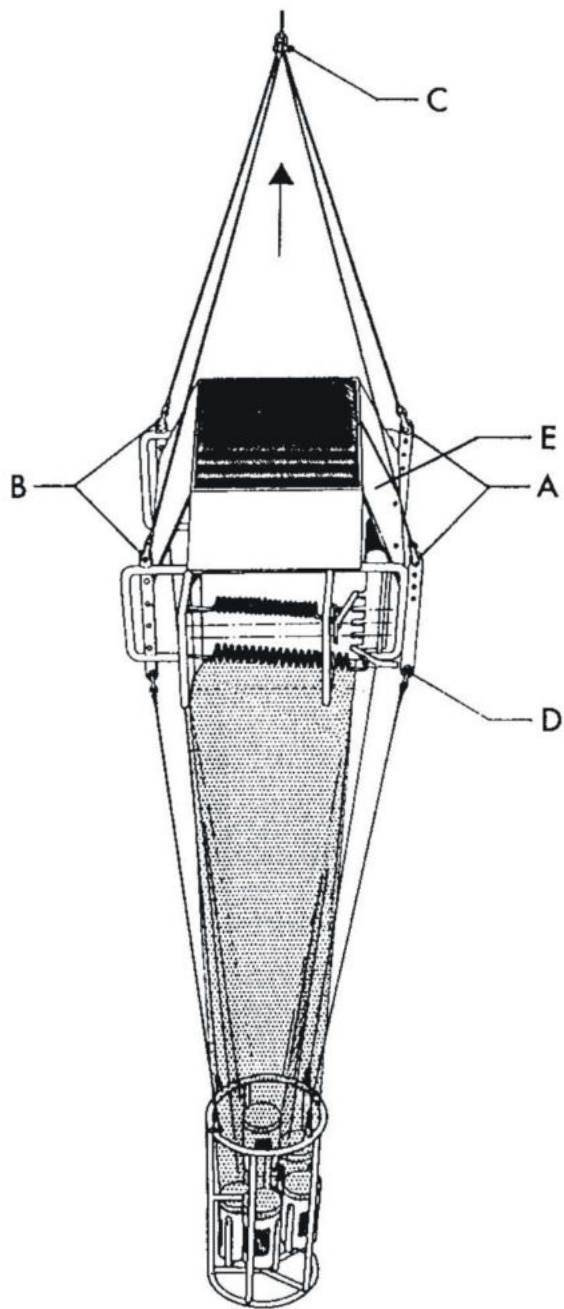

Fig. 6

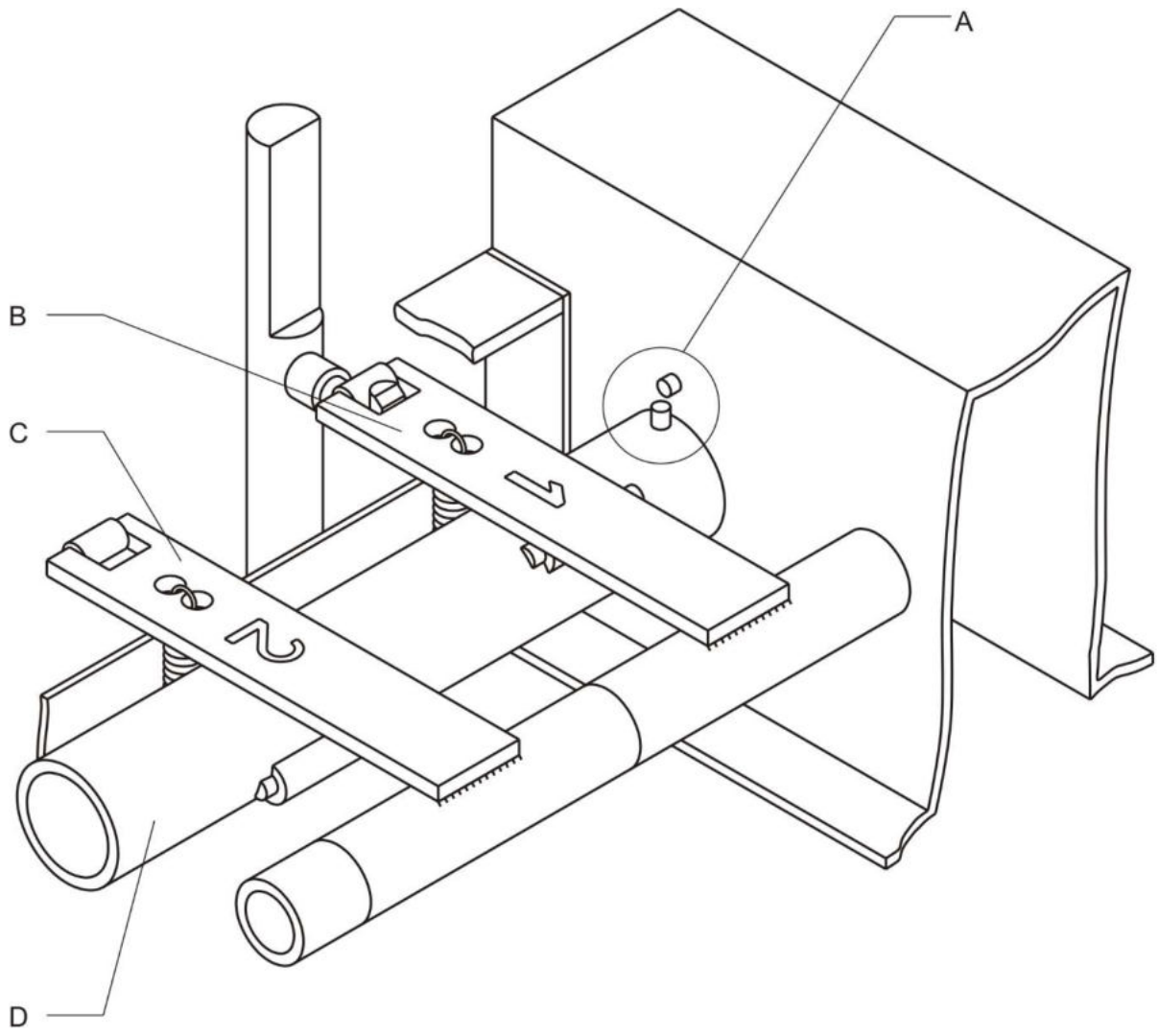

Fig. 7

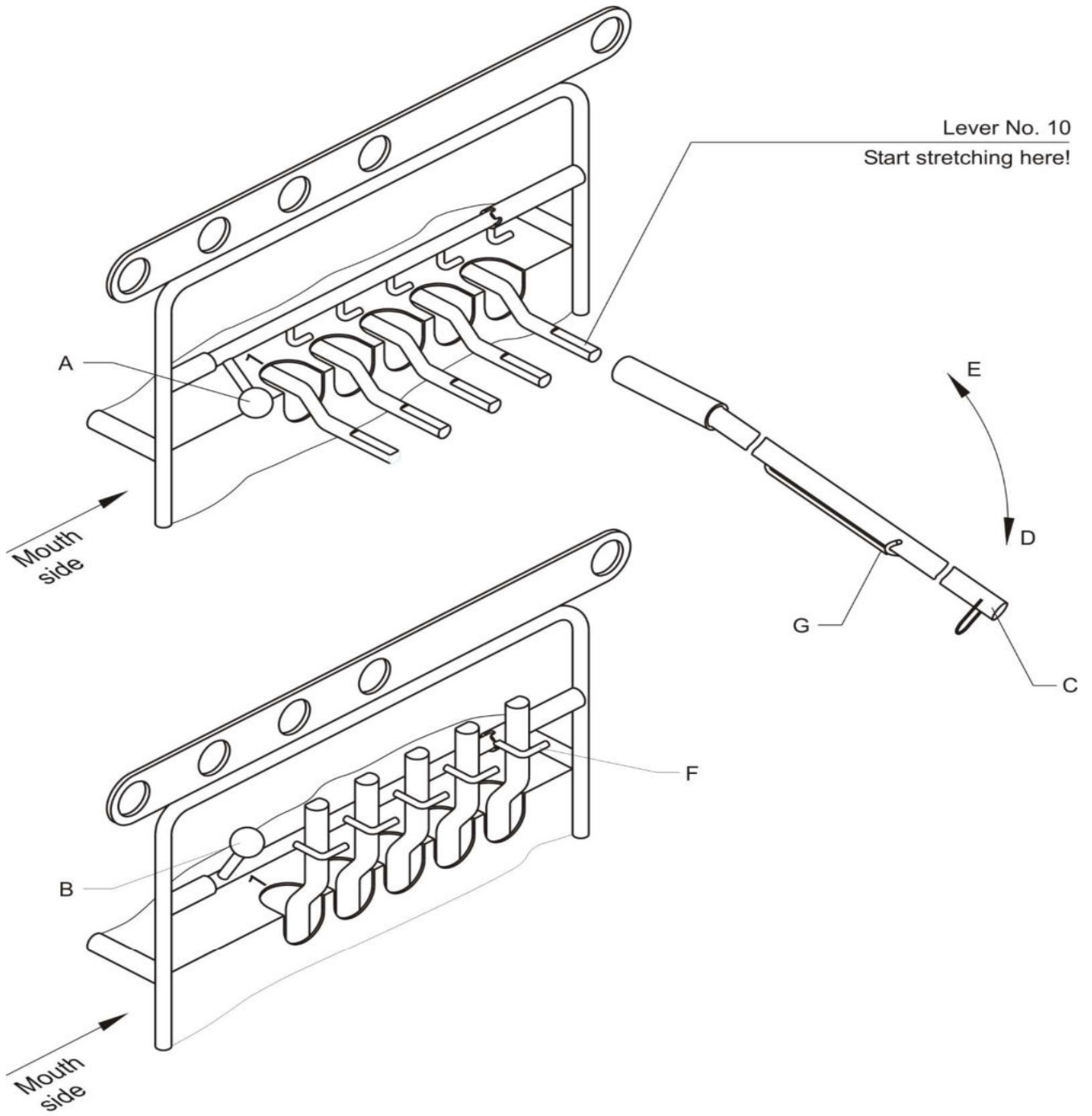

Fig. 8

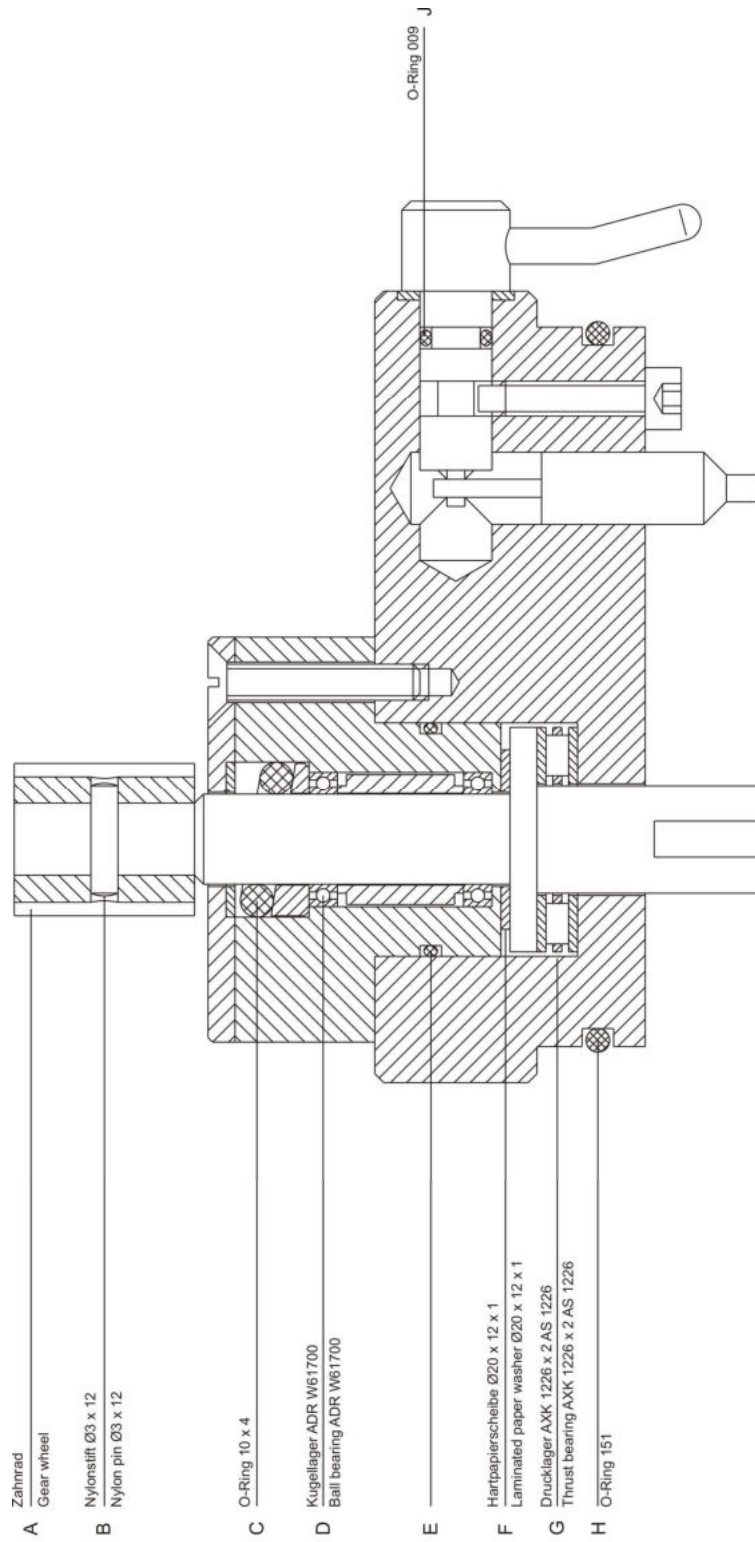
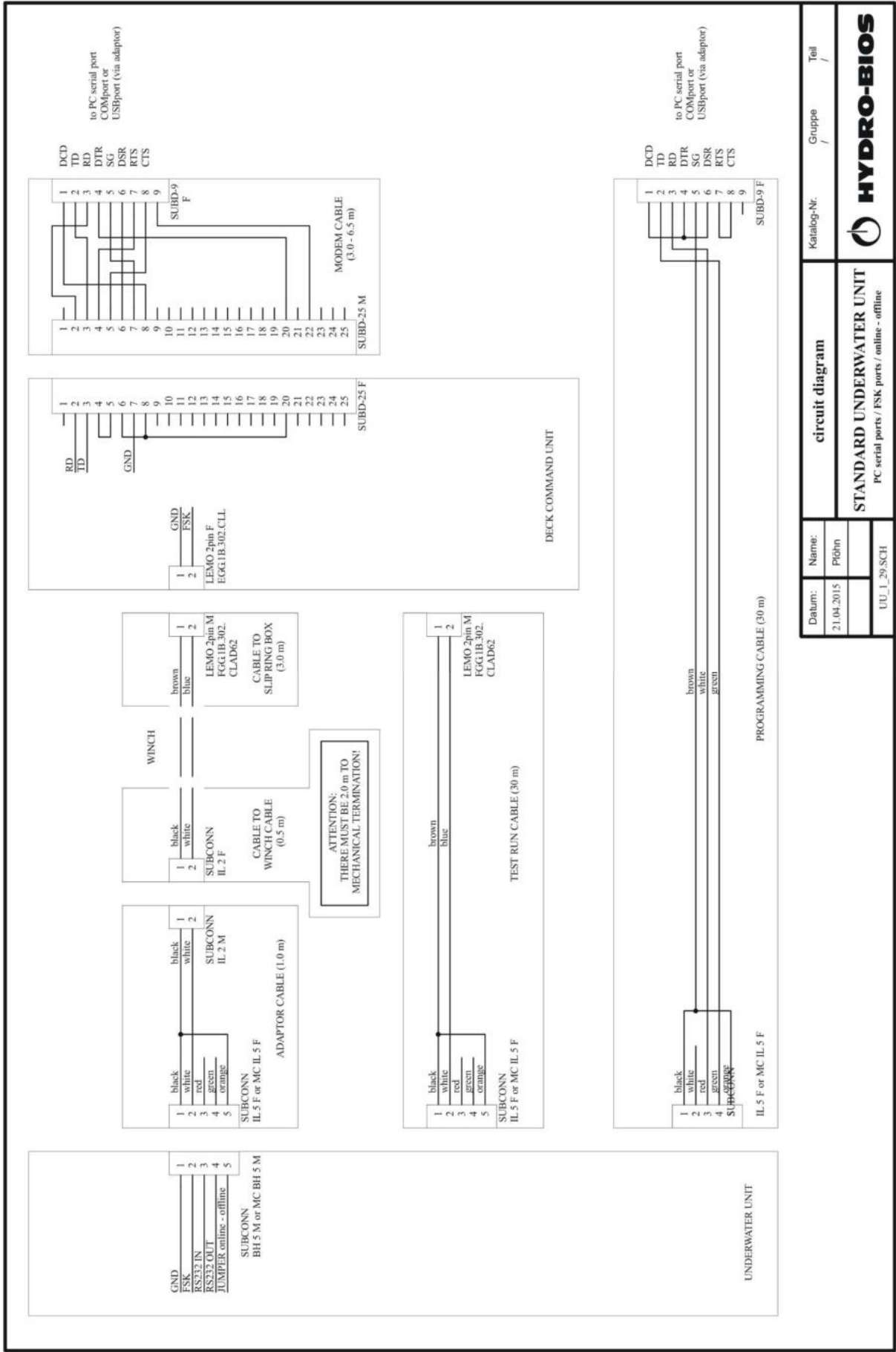

Fig. 9



Name:		Gruppe		Teil	
Datum:		Katalog-Nr.		/ /	
21.04.2015					
Plohn					
UU_1_29_SCH					



STANDARD UNDERWATER UNIT
PC serial ports / FSK ports / online - offline

circuit diagram

Wiring Scheme - Online Operation

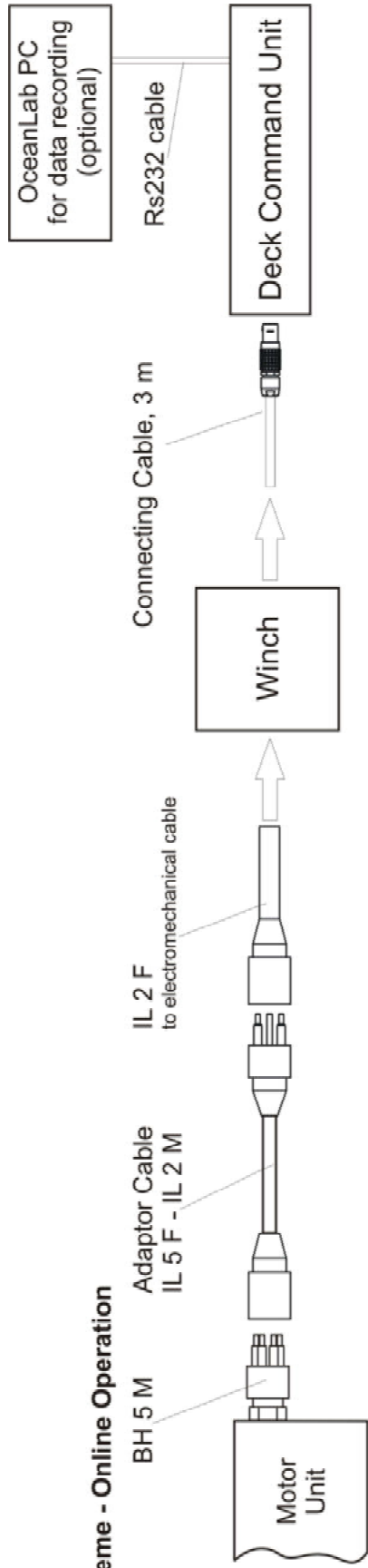

Wiring Scheme - Test Run

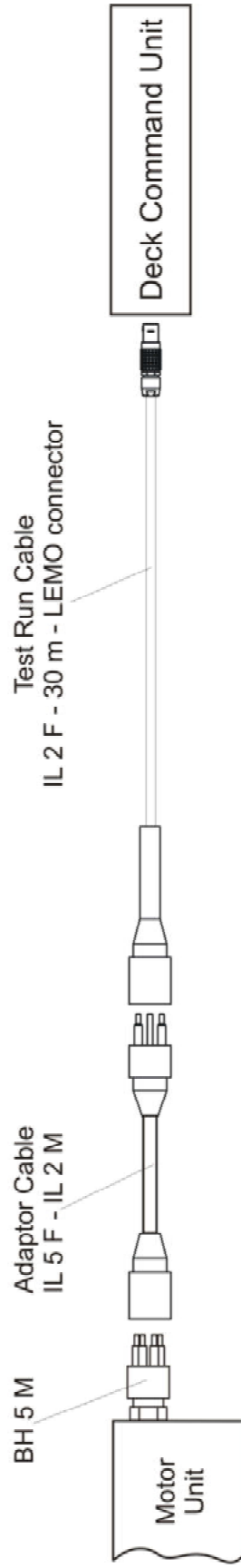

Wiring Scheme - Programming for Offline Deployment

