

Am Jägersberg 5-7
24161 Altenholz
Germany

phone.: + 49 - 4 31 - 3 69 60 - 0
fax: + 49 - 4 31 - 3 69 60 21
mail: info@hydrobios.de
sales@hydrobios.de
web: www.hydrobios.de



MULTI WATER SAMPLER SLIMLINE 6 x 5L

CATALOGUE NO. 436 977

OPERATION MANUAL

Edition 10/16

© Copyright 2016, by: **HYDRO-BIOS** Apparatebau GmbH

All rights reserved. Reproduction in every form - even by way of abstracts - with explicit permission by **HYDRO-BIOS** Apparatebau GmbH only.

CONTENTS

GENERAL DESCRIPTION.....3

STANDARD EQUIPMENT4

TECHNICAL DATA5

ELECTRICAL CONNECTION DECK COMMAND UNIT / UNDERWATER UNIT6

PREPARATION FOR OPERATION7

DECK COMMAND UNIT8

FIRST TEST RUN.....12

SECOND TEST RUN13

OPERATION.....14

REMOVAL AND MOUNTING INSTRUCTIONS OF FOR THE MOTOR.....15

LOCALIZATION OF FAULTS.....16

GENERAL DESCRIPTION

The **MULTI WATER SAMPLER SLIMLINE** is a light improved version of the HYDRO-BIOS MULTI WATER SAMPLER. It consists of Deck Command Unit and a stainless steel Underwater Array to which 6 Plastic Water Samplers of 5 litres capacity can be mounted.

The dimensions of 66 cm diameter and 98 cm height with a weight of approx. 55 kg allow an easy handling even on small research vessels.

The **MULTI WATER SAMPLER SLIMLINE** is equipped with a motor-driven release device with integrated Depth Meter - the Water Samplers are closed in the succession of their mounting to the array (i.e. no. 1, 2, 3, 4, 5 and 6).

The connection between Deck Command Unit and Underwater Unit is made by a single- or multiconductor cable.

The Underwater Array with the opened water samplers is lowered to the greatest scheduled depth where the first water sampler is closed by push button control from the Deck Command Unit.

A signal from the Underwater Unit to the Deck Command Unit indicates the number of the just closed water sampler.

The next water samplers are actuated in the desired water depths during heaving.

Power supply of the Underwater Unit is made by 3 long-time lithium batteries placed in a removable battery housing with capacity sufficient for approx. 100 hours of operation. The Deck Command Unit is mains operated (85 - 260 V AC).

In case that the research vessel is not equipped with a single- or multiconductor cable, a special offline-version is available which can be programmed to actuate the water samplers in pre-selected depths steps.

An upgrade for the Motor Unit with different sensors of various parameters is available upon request.

Technical specifications of single- or multiconductor cable see page 5.

STANDARD EQUIPMENT

1. 1 Stainless steel Underwater Array,
Motor Unit and Battery housing made of titanium,
standard operational depth: 3000 metres
1 integrated Depth Meter, standard measuring range: 3000 dbar
2. 1 Deck Command Unit with 4 plastic feet (can be pressed out from the
inside of the Deck Command Unit), incl. mains cable
3. 1 Connecting cable (to slip ring box of winch), 3 metres long Fig. 1 C
4. 1 Test Run Cable, 30 metres long Fig. 1 D
5. 1 Counter Plug SUBCONN IL 2 F Fig. 1 A
6. 1 Spare O - ring 10 x 4 for axle duct Fig. 6 C
7. 1 Spare O - ring no. 020 for axle box case Fig. 6 E
8. 1 Spare O - ring no. 151 for pressure housing Fig. 6 H
9. 1 Spare O - ring no. 009 for switch shaft Fig. 6 J
10. 1 Spare O - ring no. 120 for Battery Housing
11. 1 Can O-ring lubricant
12. 1 Can pin lubricant
13. 3 Lithium batteries DURACELL DL 123 A / 3 V (or equivalent)
14. 1 Dummy SUBCONN DC 2 M Fig. 1 B
15. 1 Dummy SUBCONN DC 2 F Fig. 1 E
16. 1 Box spanner 10 mm
17. 1 Hexagon socket screw key 5 mm
18. 1 Hexagon socket screw key 3 mm
19. 1 Spare fuse (250V AC / 0.5 A / fast) for conductor (Deck Command Unit)
20. 1 Spare fuse (125V AC / 0.5 A / fast) for conductor (Underwater Unit)
21. 4 Screws to mount the Deck Command Unit into a 19"-rack
22. 1 Operating manual
23. 1 CD-ROM OceanLab
24. 1 serial PC cable

TECHNICAL DATA

Underwater Array:

Frame dimensions: 66 cm dia. x 98 cm
Weight: 55 kg

Pressure Sensor (Depth Meter):

Standard: 0 - 3000 dbar
Option: 0 - 6000 dbar
Resolution: 0.1 dbar
Accuracy (0...50°C): typ. < 0.1%

Materials:

Underwater Array: Stainless steel
Motor Unit: Titanium
Battery housing: Titanium
Water Samplers: PVC

Operational Depth:

Standard: 3000 m
Option: 6000 m

Connector at Motor Unit:

Standard: SUBCONN BH 2 M

Cable Counter Plug:

Standard: SUBCONN IL 2 F

Deck Command Unit:

Metal housing for use in 19"-rack or as table-housing, not for use on deck (IP 20).
Push button control for activating the water samplers.
Supertwist LCD-module with LED backlight.
Indication of sampler number, depth, battery, status.

Power supply:

Underwater Unit: 3 Lithium Batteries type DL 123 A / 3 V or equivalent, capacity sufficient for approx. 100 hours of operation.
Deck Command Unit: 85 - 260 V AC / 50 - 60 Hz

Data Transmission:

Frequency shift keying (FSK), 1200 baud, 5 V / 10 mA
Short circuit protection, ESD protection.

Operating temperature:

Motor Unit: - 40...+ 85°C
Deck Command Unit: 0 ... + 70°C

Cable connection:

Single- or multiconductor cable, one pole can be in contact with sea water.
Minimum breaking load 1000 kg.
Cable resistance (go and return line) max. 1000 Ohms.

The single- or multiconductor cable is not included in our scope of delivery!

ELECTRICAL CONNECTION DECK COMMAND UNIT / UNDERWATER UNIT

1. The connection between Deck Command Unit and Underwater Unit is made by a single- or multiconductor cable. **This cable is not included in our scope of delivery.**
2. The minimum breaking load of the cable shall be 1000 kg.
3. The cable resistance (go and return line) should not exceed 1000 Ohms.
4. Single conductor cable (one core isolated and one outer steel armor):
The isolated core of the cable has to be connected to the white core of PIN 2 of the connector SUBCONN IL 2 F (Fig. 1 A), the outer steel armor of this cable has to be connected to the black core of PIN 1.
5. Multi conductor cable:
Any two cores of this cable are connected to the cores of the supplied connector SUBCONN IL 2 F (Fig. 1 A).
6. When the existing single- or multiconductor cable is already equipped with an underwater connector, the supplied plug SUBCONN IL 2 F (Fig. 1 A) has to be combined with a corresponding counter plug of the existing plug-in connection to a cable adaptor.
7. The cable connection of the other end of the single- or multiconductor cable to the Deck Command Unit (via slip rings at the cable winch) is made by using the connecting cable (Fig. 1 C). The core connected to PIN 1 of the connector IL 2 F (Fig. 1 A) has to be connected to the brown core of the connecting cable (Fig. 1 C). The core connected to PIN 2 of the connector SUBCONN IL 2 F (Fig. 1 A) has to be connected to the blue core of the connecting cable (Fig. 1 C).
8. When the single- or multiconductor cable is not used, the connector SUBCONN IL 2 F (Fig. 1 A) should always be protected by the DUMMY SUBCONN DC 2 M (Fig. 1 B) to avoid corrosion of the contacts. Beforehand the contacts should be slightly greased with the special PIN-lubricant.

**The connection of the SUBCONN connector to the single- or multiconductor cable
has to be made with greatest care.**

Most malfunctions are caused by cable connecting faults!

PREPARATION FOR OPERATION

1. The Deck Command Unit has to be brought into a dry room.
An operation on deck is not allowed!
2. The main switch **POWER** of the Deck Command Unit has to be switched into position **0** (Fig. 4 B).
3. Switch lever switch at the outside of the Motor Unit into position **0** (Fig. 2 F).
4. Remove changeable rack no. 5 (Fig 3 K) from the array. Tool: Spanner 10 mm
5. Unplug the cable connection between Battery Housing and Motor Unit.
6. Loosen the Battery Housing from the Motor Unit by screwing the star grip screw counter-clockwise.
7. Bring the Battery Housing into a dry room.
8. Unscrew the union nut from the Battery Housing and remove pressure tube.
9. Place 3 lithium batteries DURACELL DL 123 A / 3 V or equivalent into the battery holders. Take care of **correct polarity**. Secure all batteries with retainer covers.
10. Make sure that the sealing surface in the pressure tube is clean. If necessary use a lintfree cloth for cleaning.
Do not use absorbent cotton!
11. Slightly grease the sealing surface in the pressure tube with O-ring lubricant.
12. Make sure that the O-ring in the flange is clean and uninjured. If necessary use a lintfree cloth for cleaning.
13. If the O-ring is defective, use a blunt tool (e.g.ball point pen cartridge or a piece of wood) to take the O-ring out of the groove.
Take care that the groove in the flange will not be damaged!
14. Make sure that the groove in the flange is clean and uninjured. If necessary use a lintfree cloth for cleaning.
Do not use absorbent cotton!
15. Slightly grease a spare O-ring no. 120 with O-ring lubricant.
16. Put the greased O-ring into the groove of the flange.
17. Carefully press the flange into the pressure tube.
18. Fasten the flange at the pressure tube with the plastic union nut.
19. Slightly grease the pins of the underwater connectors with pin lubricant.
20. Re-establish the electrical connection between Battery Housing and Motor Unit.
21. Place the Battery Housing in its seat at the Motor Unit.
22. Fix the Battery Housing at the Motor Unit with the star grip screw.
Do not use any tool!
23. Batteries have to be changed when battery voltage falls below 7 V (See DECK COMMAND UNIT, page 8).
24. Remount changeable rack no. 5 to the array (Fig. 3 K). Tool: Spanner 10 mm

DECK COMMAND UNIT: COMPONENTS AND MAIN SCREEN

The Deck Command Unit is equipped with the following components:

1. Socket for mains cable with integrated mains fuse (250 V AC / 2 A / slow) located at rear side of the housing (Fig. 4 A).
2. Main switch **POWER**, illuminated (Fig 4 B).
3. Socket **UNDERWATER UNIT** to connect the Underwater Unit via Test Run Cable resp. single or multi conductor cable (Fig. 4 C).
4. Socket **PERSONAL COMPUTER SERIAL PORT** (Fig. 4 D) to connect a PC.
5. Push button **ACTION** (Fig. 4 E) to actuate the water samplers in the succession of their mounting to the array.
6. Keyboard **MENU + - ENTER** for menu control (Fig. 4 F).
7. Alphanumeric display (four lines, 40 characters each) with backlight (Fig. 4 G).
8. Regulating screw **CONTRAST** to adjust the contrast of the alphanumeric display, located at rear side of the housing (Fig. 4 A).
9. Fuse (250 V AC / 0.5 A / fast) for CONDUCTOR, located at rear side of the housing.

The following screens are displayed at the alphanumeric display:

MAIN SCREEN:

The main screen appears if Deck Command Unit and Underwater Unit are switched on and a correct cable connection has been established.

MULTI WATER SAMPLER 6 bottles / 3000m UNDERWATER UNIT: MOTOR RUNS PRESS 0180.5 dbar BOTTLE 01 closed BATTERY 9.6 V
--

The first line of the main screen indicates the connected underwater equipment incl. the range of the integrated depth meter.

To avoid damages do not exceed the maximum operational depth of the depth meter.

The second line indicates:

UNDERWATER UNIT: MOTOR RUNS Current activating process of a sampler.

UNDERWATER UNIT: END OF OPERATION The last sampler has been activated.

During the rest of operation the second line is used as display for messages (see below).

The third line of the main screen includes:

PRESS 0180.5 dbar actual pressure value of the integrated Pressure Sensor.

BOTTLE 01 closed the number of the last closed water sampler.

The fourth line of the main screen indicates:

BATTERY 9.6 V the actual battery voltage of the Underwater Unit.

The batteries should be changed when the battery voltage falls below 7 V during a period with inactive motor. Upon reaching a battery voltage of less than 1.5 V the Underwater Unit will be switched off automatically. A restart requires a new set of batteries.

DECK COMMAND UNIT: ERROR MESSAGES AND MENU SCREEN

ERROR MESSAGES:

The following error messages will be displayed in the **second line** of the display only:

UNDERWATER UNIT: NO DATA No data received from the Underwater Unit:

The Motor Unit is switched off or not connected, or the batteries of the Motor Unit are exhausted, or the cable connection between Deck Command Unit and Motor Unit is interrupted.

UNDERWATER UNIT: INVALID DATA data received from the Underwater Unit are invalid:

The connected Motor Unit is not compatible with the Deck Command Unit.

SINGLE CONDUCTOR CABLE: SHORT CIRCUIT short-circuit detected in the cable connection between Deck Command Unit and Motor Unit.

MENU SCREEN:

To call the main menu screen press **MENU** key of the keyboard:

MENU	>	QUIT MENU
		MANUAL MOTOR CONTROL
SELECT: +/-		RESET BOTTLE NUMBER
START: ENTER		RESET PRESSURE SENSOR

The left column of the main menu screen includes:

MENU Indication for main menu.

SELECT: +/- To select a menu item press **+** or **-** key.

By pressing the **+** key the marker **>** will be moved to the line below, by pressing the **-** key the marker **>** will be moved to the previous line.

START: ENTER To enter the selected menu press **ENTER** key.

The right column of the main menu screen includes the following menu items:

QUIT MENU To quit menu screen and return to main screen.

MANUAL MOTOR CONTROL (accessible with Motor Unit connected only) to start out a short motor run (1/2 revolution of the motor axle) and to set the bottle number to **0**, used to synchronize Motor Unit with Deck Command Unit.

RESET BOTTLE NUMBER (accessible with Motor Unit connected only) to set the bottle number to **0**, used to synchronize Motor Unit with Deck Command Unit.

RESET PRESSURE SENSOR (accessible with Motor Unit connected only) to recalibrate the Pressure Sensor. Use menu item whilst Underwater Unit stands on deck at temperatures from +5°C to +35°C only.

**DECK COMMAND UNIT: QUIT MENU
MANUAL MOTOR CONTROL**

MENU ITEM: QUIT MENU:

Call this menu item to quit the menu screen and to return to the main screen.

MENU ITEM: MANUAL MOTOR CONTROL:

MANUAL MOTOR CONTROL START MOTOR: PRESS ENTER MOTOR TURNS QUIT: MENU

MANUAL MOTOR CONTROL Indication of menu item.

START MOTOR: PRESS ENTER To start out a short motor run (1/2 revolution of the motor axle) press the **ENTER** key. Additionally the bottle number is set to **0**. will be displayed for approx. 1.5 sec. after pressing the **ENTER** key.

MOTOR TURNS

QUIT: MENU

To quit menu item (without or after carrying out a short motor run) and return to menu screen press **MENU** key.

**DECK COMMAND UNIT: RESET BOTTLE NUMBER
RESET PRESSURE SENSOR**

MENU ITEM: RESET BOTTLE NUMBER:

RESET BOTTLE NUMBER SET NUMBER TO ZERO: PRESS ENTER BOTTLE = 00 QUIT: MENU

RESET BOTTLE NUMBER Indication of menu item.

SET NUMBER TO ZERO: PRESS ENTER To reset the bottle number press **ENTER**.

BOTTLE = 00 Return signal from the Underwater Unit after pressing **ENTER** key.

QUIT: MENU To quit menu item and return to menu screen press **MENU** key.

MENU ITEM: RESET PRESSURE SENSOR:

RESET PRESSURE SENSOR SET PRESSURE TO ZERO: PRESS ENTER PRESSURE = 0000.0 dbar QUIT: MENU
--

RESET PRESSURE SENSOR Indication of menu item.

SET PRESSURE TO ZERO: PRESS ENTER To recalibrate the Pressure Sensor press the **ENTER** key.

Use menu item whilst Underwater Unit stands on deck at temperatures from +5°C to +35°C and has reached surrounding temperature only.

The recalibration is irreversible!

PRESSURE = 0000.0 dbar Return signal from the Underwater Unit after pressing **ENTER** key.

QUIT: MENU To quit menu item and return to menu screen press **MENU** key.

FIRST TEST RUN

In order to control the function of the Deck Command Unit and the Underwater Unit the following steps are to be carried out:

THE WATER SAMPLERS MUST NOT BE OPENED FOR THE TEST RUN !

1. The Deck Command Unit has to be switched off, the main switch **POWER** (Fig. 4 B) is not illuminated.
2. The lever key of the Underwater Unit has to be switched to position **O** (Fig. 2 F).
3. Connect the Test Run Cable (Fig. 1 D) to the Deck Command Unit (Fig. 4 C).
4. Remove the dummy DC 2 F from the Underwater Unit (Fig. 1 E).
5. Slightly grease the pins of the connector BH 2 M (Fig. 2 A) of the Underwater Unit with the PIN-lubricant.
6. Connect the Test Run Cable (Fig. 1 D) to the Underwater Unit (Fig. 2 A).
7. Lift the striking bar **J** of the rack no. **1** and put rope **D** with the plastic ball **C** into the corresponding slit no. **1** (Fig. 2, Fig. 3).
8. Repeat this procedure for racks no. **2** to no. **6**.
9. Switch on the Deck Command Unit, the main switch **POWER** is illuminated (Fig. 4 B), the display indicates: **UNDERWATER UNIT: NO DATA**
10. The lever key of the Underwater Unit has to be switched to position **I** (Fig. 2 F), the main screen appears at the display of the Deck Command Unit.

MULTI WATER SAMPLER 6 bottles / 3000 m
PRESS 0000.0 dbar BOTTLE 00 closed
BATTERY 9.6 V

11. Now press push button **ACTION** at the Deck Command Unit (Fig. 4 E). The second line of the display indicates with **UNDERWATER UNIT: MOTOR RUNS** the current activating process of the first water sampler. After 2 seconds the indication of the bottle number is updated: **BOTTLE 01 closed**. One second later the activating process of the first water sampler is completed, the text in the second line of the display disappears.
12. The procedure (as described in point 11.) has to be repeated another 5 times. Finally the second line of the display indicates with **UNDERWATER UNIT: END OF OPERATION** that a complete operation has been simulated. The release block (Fig. 2 B) is now again between slit no. **1** and no. **6** (Fig. 2).
13. Switch off Underwater Unit (Fig. 2 F) and Deck Command Unit (Fig. 4 B).
14. Remove the Test Run Cable (Fig. 1 D).

When a **SECOND TEST RUN** of the **MULTI WATER SAMPLER MWS** is not intended, plug the dummy DC 2 F (Fig. 1 E) onto the connector BH 2 M (Fig. 2 A) and plug the dummy DC 2 M (Fig. 1 B) into the connector IL 2 F (Fig. 1 A) of the single or multi conductor cable. Beforehand the contacts should be slightly greased with the special Pin-lubricant.

SECOND TEST RUN

In order to control the function of the Deck Command Unit and the Underwater Unit together with the single or multi conductor cable the following steps are to be carried out:

THE WATER SAMPLERS MUST NOT BE OPENED FOR THE TEST RUN !

1. The Deck Command Unit has to be switched off, the main switch **POWER** (Fig. 4 B) is not illuminated.
2. The lever key of the Underwater Unit has to be switched to position **O** (Fig. 2 F).
3. Connect the connection cable from the slip ring box of the winch (Fig. 1 C) to the Deck Command Unit (Fig. 4 C).
4. Slightly grease the pins of the connector BH 2 M (Fig. 2 A) of the Underwater Unit with the PIN-lubricant.
5. Connect the single or multi conductor cable (Fig. 1 A) to the Underwater Unit (Fig. 2 A).
6. Lift the striking bar **J** of the rack no. **1** and put rope **D** with the plastic ball **C** into the corresponding slit no. **1** (Fig. 2, Fig. 3).
7. Repeat this procedure for racks no. **2** to no. **6**.
8. Switch on the Deck Command Unit, the main switch **POWER** is illuminated (Fig. 4 B), the display indicates: **UNDERWATER UNIT: NO DATA**
9. The lever key of the Underwater Unit has to be switched to position **I** (Fig. 2 F), the main screen appears at the display of the Deck Command Unit.

MULTI WATER SAMPLER 6 bottles / 3000 m
PRESS 0000.0 dbar BOTTLE 00 closed
BATTERY 9.6 V

10. Now press push button **ACTION** at the Deck Command Unit (Fig. 4 E). The second line of the display indicates with **UNDERWATER UNIT: MOTOR RUNS** the current activating process of the first water sampler. After 2 seconds the indication of the bottle number is updated: **BOTTLE 01 closed**. One second later the activating process of the first water sampler is completed, the text in the second line of the display disappears.
11. The procedure (as described in point 10.) has to be repeated another 5 times. Finally the second line of the display indicates with **UNDERWATER UNIT: END OF OPERATION** that a complete operation has been simulated. The release block (Fig. 2 B) is now again between slit no. **1** and no. **6** (Fig. 2).
12. Switch off Underwater Unit (Fig. 2 F) and Deck Command Unit (Fig. 4 B).

When an operation of the MULTI WATER SAMPLER MWS is not intended, the single or multi conductor cable has to be removed. To avoid corrosion of the contacts, plug the dummy DC 2 F (Fig. 1 E) onto the connector BH 2 M (Fig. 2 A) and plug the dummy DC 2 M (Fig. 1 B) into the connector IL 2 F (Fig. 1 A) of the single or multi conductor cable. Beforehand the contacts should be slightly greased with the special Pin-lubricant.

OPERATION

When the connector IL 2 F has been attached to the single or multi conductor cable newly resp. when a new cable adapter has been produced, a continuous supervision of the display of the Deck Command Unit is recommended during the first operation. Upon receiving an error message (see page 9) switch off the Deck Command Unit and recover the instrument immediately. The localization and repair of faults will be made according to chapter LOCALIZATION OF FAULTS, page 16.

1. When the MULTI WATER SAMPLER MWS has not been operated for a longer period, a SECOND TEST RUN acc. to page 13 should be carried out to control proper functioning of the system.
2. The Deck Command Unit has to be switched off, the main switch **POWER** (Fig. 4 B) is not illuminated.
3. The lever key of the Underwater Unit has to be switched to position **O** (Fig. 2 F).
4. Lift the striking bar **J** of the rack no. **1** and put rope **D** with the plastic ball **C** into the corresponding slit no. **1** (Fig. 2, Fig. 3).
5. Repeat this procedure for racks no. **2** to no. **6**.
6. The Water Samplers are opened as described on the label (Fig. 5). Carry out **step 1** and **step 2**, **step 3** is not applicable.
7. Switch on the Deck Command Unit, the main switch **POWER** is illuminated (Fig. 4 B), the display indicates: **UNDERWATER UNIT: NO DATA**
8. The lever key of the Underwater Unit has to be switched to position **I** (Fig. 2 F), the main screen appears at the display of the Deck Command Unit.

MULTI WATER SAMPLER 6 bottles / 3000 m
PRESS 0000.0 dbar BOTTLE 00 closed
BATTERY 9.6 V

9. The Underwater Unit is lowered to the greatest scheduled depth, the winch has to be stopped.
10. To close the first water sampler press push button **ACTION** at the Deck Command Unit (Fig. 4 E). The second line of the display indicates with **UNDERWATER UNIT: MOTOR RUNS** the current activating process of the first water sampler. 2 seconds later the indication of the bottle number is updated: **BOTTLE 01 closed**. After one more second the activating process of the first water sampler is completed, the text in the second line of the display disappears.
11. The Underwater Unit has to be heaved by the winch to the next sampling depth.
12. The winch has to be stopped again and the next water sampler is closed as described in point 10.
13. This procedure has to be repeated for water samplers no. **3** up to no. **6**
14. Switch off Underwater Unit (Fig. 2 F) and Deck Command Unit (Fig. 4 B) when the Underwater Unit is back on board.

The single or multi conductor cable must not be removed from the Underwater Unit when more than one operation is planned during an expedition.

When a further operation of the MULTI WATER SAMPLER MWS is not intended, the single or multi conductor cable has to be removed. To avoid corrosion of the contacts, plug the dummy DC 2 F (Fig. 1 E) onto the connector BH 2 M (Fig. 2 A) and plug the dummy DC 2 M (Fig. 1 B) into the connector IL 2 F (Fig. 1 A) of the single or multi conductor cable. Beforehand the contacts should be slightly greased with the special Pin-lubricant.

REMOVAL AND MOUNTING INSTRUCTIONS FOR THE MOTOR

When the motor of the Underwater Unit has to be removed for repair resp. maintenance, the following steps have to be carried out:

Removal

1. Remove the Test Run Cable resp. single or multi conductor cable from the Underwater Unit.
2. Unscrew 3 hexagon socket screws M 6 (Fig. 2 G). and remove the motor housing.
Tool: Hexagon Socket Screw Key 5 mm

Mounting

The Underwater Unit does only work properly, when the synchronization between motor and gearing has been established. The synchronization is not in order, when

- a) the driving toothed wheel of the motor has been turned electrically or mechanically in dismantled condition
- b) the the red releaser is not positioned between slit no. **1** and no. **6** of the basic ring (Fig. 2 B)

In order to re-establish the synchronization before mounting, the following steps have to be carried out:

1. Connect the Test Run Cable (Fig. 1 D) to the Deck Command Unit (Fig. 4 C).
2. Connect the Test Run Cable (Fig. 1 D) to the removed motor housing (Fig. 2 A).
3. Switch on the Deck Command Unit, the main switch **POWER** is illuminated (Fig. 4 B), the display indicates :

UNDERWATER UNIT: NO DATA

4. The lever key of the motor housing has to be switched to **I** (Fig. 2 F), the main screen appears at the display of the Deck Command Unit (see DECK COMMAND UNIT, page 8).
5. Press the **MENU** key to call the main menu screen.
6. Select menu item **MANUAL MOTOR CONTROL** by pressing the **+** key and enter the menu item by striking the **ENTER** key.
7. Press **ENTER** key again to carry out a short motor run (half revolution of the motor axle) and to set the bottle number to zero.
8. Return to the main menu screen by pressing **MENU** key.
9. Select menu item **QUIT MENU** and return to the main screen by pressing the **ENTER** key.
10. The motor is synchronized and ready for remounting.
11. The red releaser block is to be turned by hand until it is positioned between slit no. **1** and no. **6** of the basic ring (Fig. 2 B).
12. Now the motor is mounted with the 3 hexagon socket screws M 6 onto the gear box without distorting the position of the red releaser block.
Tool: Hexagon Socket Screw Key 5 mm
13. Carry out a **FIRST TEST RUN** (see page 12).

LOCALIZATION OF FAULTS

In order to localize the reason for a fault, comply with the following instructions.

After switching on the Deck Command Unit the main switch **POWER** (Fig. 4 B) is not illuminated, the display is empty:

1. Mains cable is not (or not correct) connected to the socket at the rear side of the Deck Command Unit or the mains supply. Check these connections.
2. Integrated main fuse burnt out. Disconnect the mains cable from the Deck Command Unit. Change main fuse (250 V AC / 2 A / slow) located in the posterior partition of the drawer (reserve fuse in the anterior partition) below the mains cable connector at the rear side of the Deck Command Unit.
3. Mains cable is defective, it has to be replaced.
4. No voltage at the mains socket. Check mains socket, line and mains supply.

Error message **UNDERWATER UNIT: NO DATA** occurs:

1. Underwater Unit is not connected. Check the connection at Deck Command Unit and Underwater Unit.
2. Underwater Unit is switched off. Switch on the Underwater Unit.
3. Batteries of the Underwater Unit are exhausted. Insert a new set of batteries (see PREPARATION FOR OPERATION, page 7).
4. The cable between Deck Command Unit and Underwater unit is broken. To localize cable faults comply with the instructions below.
5. The integrated fuses of Deck Command Unit (250 V AC / 0,5 A / fast, located at the rear side of the housing) and Underwater Unit (125 V AC / 0,5 A / fast, located at the electronics board) for the CONDUCTOR are burnt out. They have to be replaced.

Error message **SINGLE CONDUCTOR CABLE: SHORT CIRCUIT** occurs:

1. The cable connection between Deck Command Unit and Underwater Unit has wrong polarity. Both cores have to be interchanged (compare to ELECTRICAL CONNECTION DECK COMMAND UNIT / UNDERWATER UNIT, page 6).
2. The cable connection between Deck Command Unit and Underwater Unit has a short circuit. To localize cable faults comply with the instructions below.

Error message **UNDERWATER UNIT: INVALID DATA** occurs:

1. The received data are not valid, the Deck Command Unit does not support the connected Underwater Unit. Use correlated Underwater Unit.

MOST MALFUNCTIONS ARE CAUSED BY CABLE FAULTS !

In order to localize a cable fault comply with the following instructions:

1. Check the connection between the plug SUBCONN IL 2 F (Fig. 1 A) and the single or multi conductor cable (and check the cable adapter if used).
90% of all faults are found here !
2. Check the connection from single or multi conductor cable to the slip rings of the cable winch.
3. Check the slip rings of the cable winch.
4. Check the cable connection between cable winch and Deck Command Unit.

After localization and removal of faults carry out a **SECOND TEST RUN** (page 13) for control purposes. When the **SECOND TEST RUN** has been completed successfully, the **MULTI WATER SAMPLER SLIMLINE** is ready for operation again.

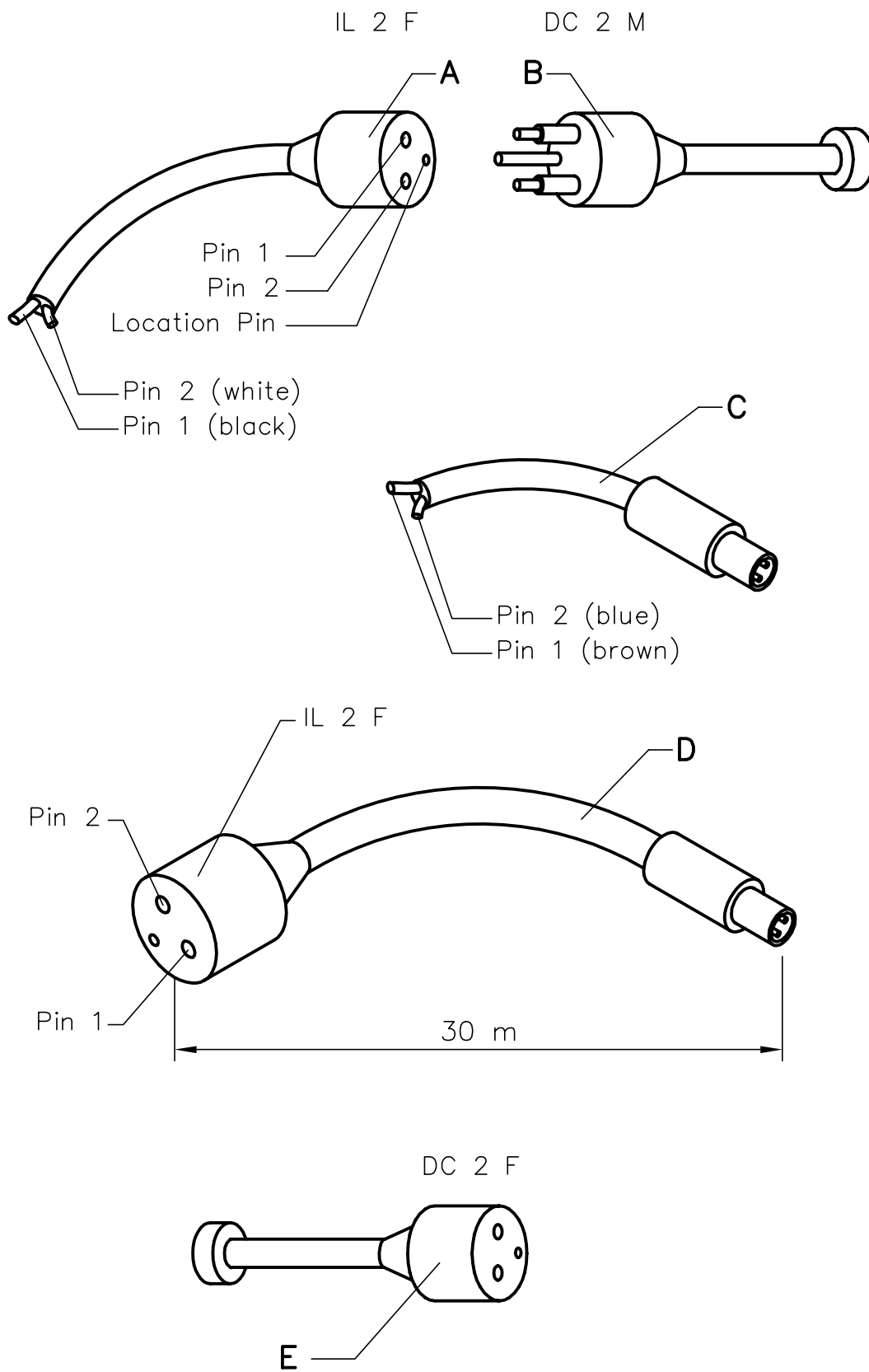

Fig. 1

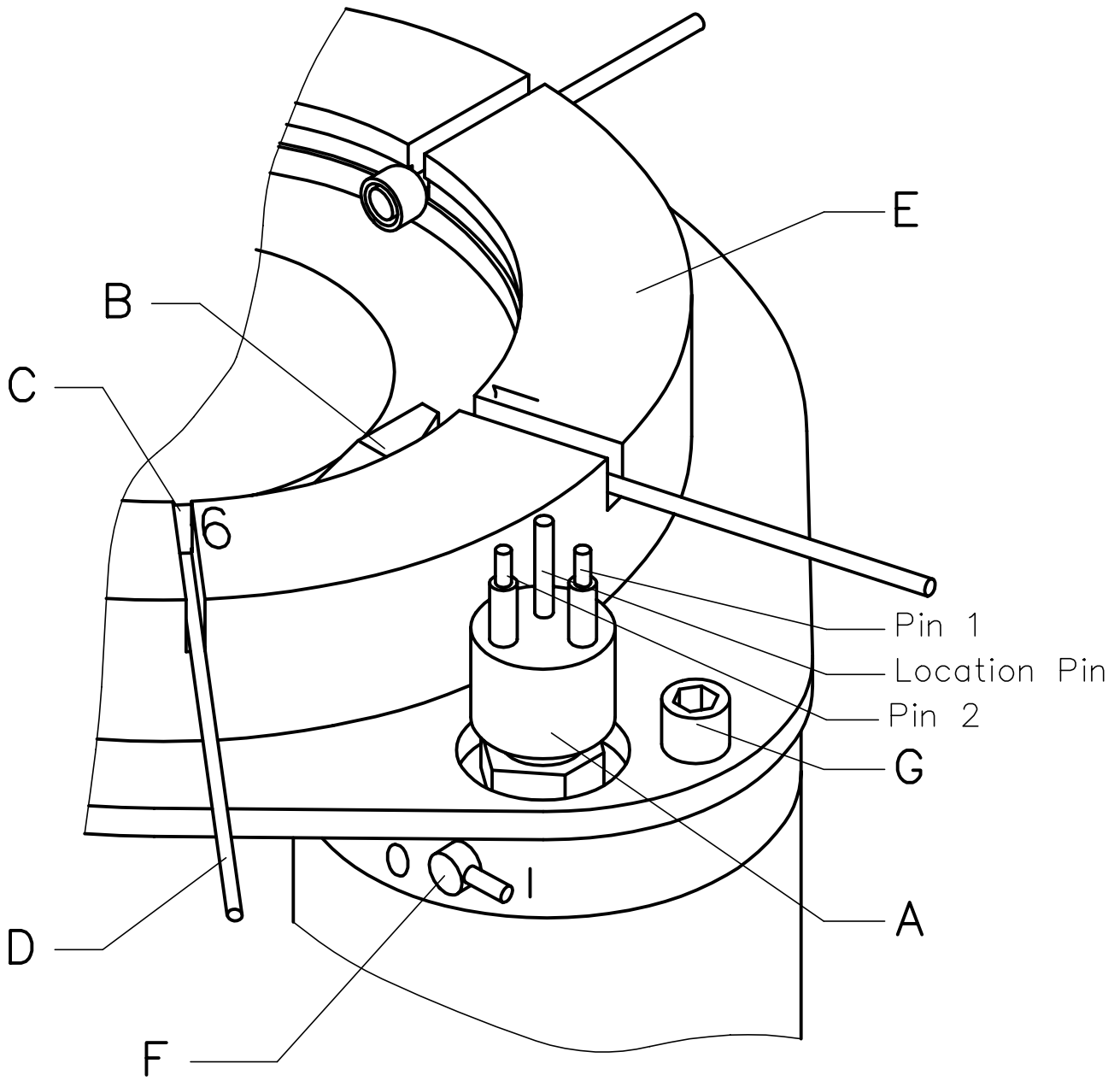

Fig. 2

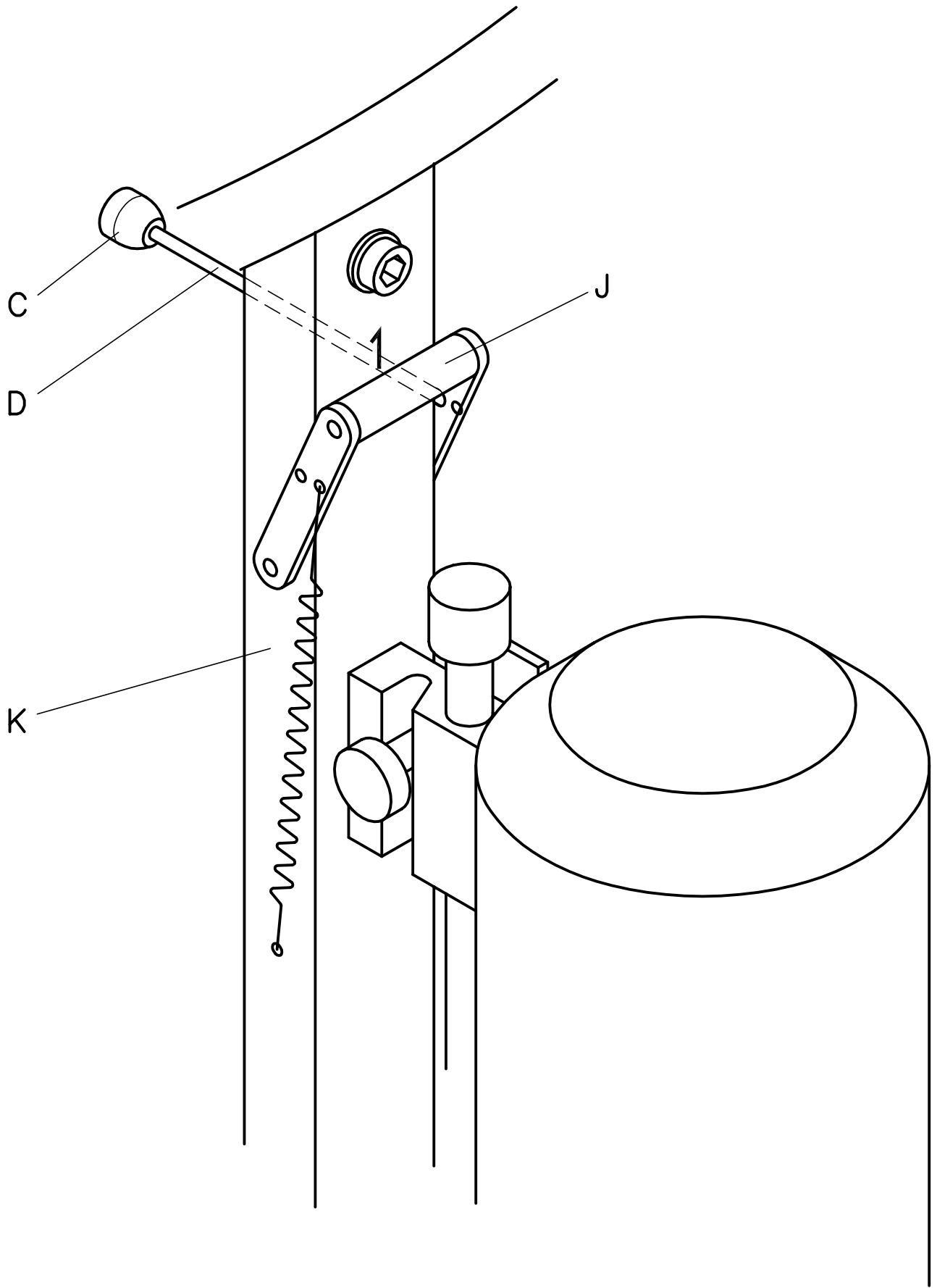

Fig. 3

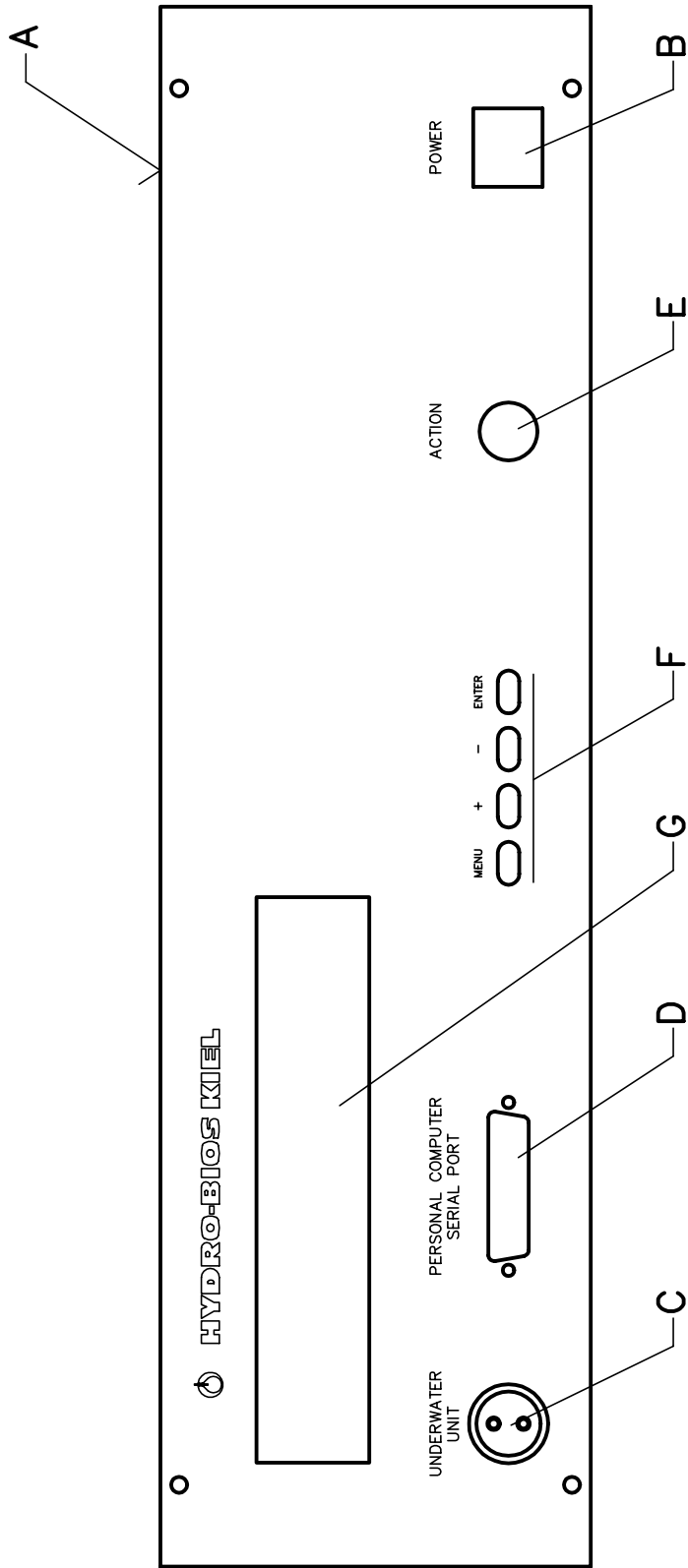
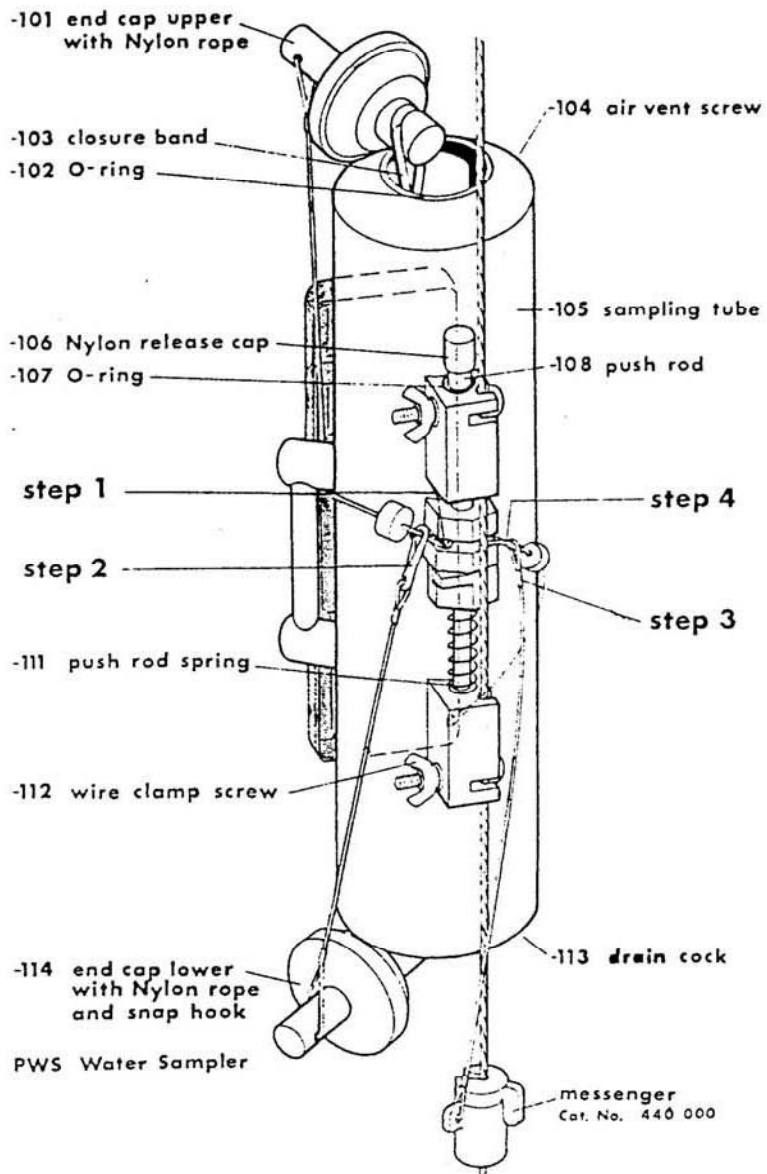

Fig. 4

DON'T CLOSE WATERSAMPLER ON AIR!



HYDRO-BIOS KIEL

Fig. 5

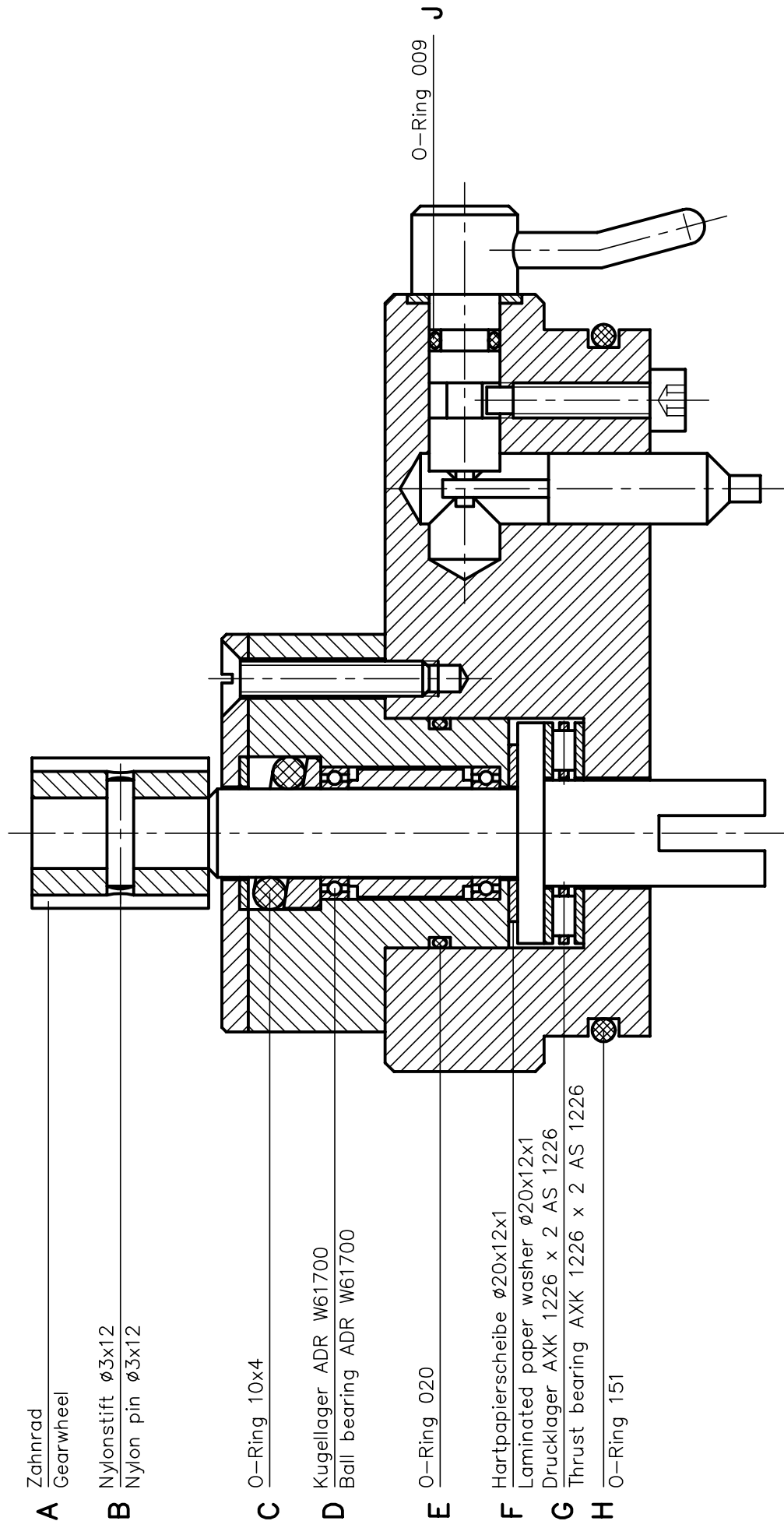

Fig. 6

Am Jägersberg 5-7
24161 Altenholz
Germany

phone.: + 49 - 4 31 - 3 69 60 - 0
fax: + 49 - 4 31 - 3 69 60 21
mail: info@hydrobios.de
sales@hydrobios.de
web: www.hydrobios.de



OFFLINE-SET OF MULTI WATER SAMPLER SLIMLINE

OPERATION MANUAL

Edition 10/16

© Copyright 2016, by: **HYDRO-BIOS** Apparatebau GmbH

All rights reserved. Reproduction in every form – even by way of abstracts – with explicit permission by **HYDRO-BIOS** Apparatebau GmbH only.

CONTENTS

GENERAL DESCRIPTION.....3
STANDARD EQUIPMENT4
TECHNICAL DATA5
OPERATING MODES6
ONLINE-OPERATIONS7
OFFLINE-OPERATIONS.....8

GENERAL DESCRIPTION

The **OFFLINE-SET FOR MULTI WATER SAMPLER SLIMLINE** is an upgrade for the standard **MULTI WATER SAMPLER SLIMLINE** allowing operations without the need of a conductor cable between the Underwater Unit and the ship. With the **OFFLINE-SET** the **MULTI WATER SAMPLER SLIMLINE** is programmed prior to operation with the PC-software **OceanLab** enabling the user to pre-select closing pressures (depths) for the water samplers in successive water layers. Thus the **MULTI WATER SAMPLER SLIMLINE** can be operated with a normal steel wire.

Using a steel wire (no single conductor cable required) the pre-programmed **MULTI WATER SAMPLER SLIMLINE** is brought to water with all water samplers opened. Upon reaching the pre-programmed unlocking pressure, the Motor Unit is unlocked. During heaving the water samplers are closed according to the pre-selected pressure steps.

The measuring data of integrated sensors are stored in a data memory of 16 MByte with a data rate of 1 Hz. Considering the number of 5 to 25 Bytes per data set (depending on sensor configuration of the instrument) the data memory allows for 180 to 900 hours of operation. The stored data can be transferred to a PC by using the data acquisition software **OceanLab**.

STANDARD EQUIPMENT

1. 1 Electronics board including 16 MByte data memory, integrated into the Motor Unit
2. 1 Programming cable SUBCONN MC IL 5 F --> Sub-D 9 pin, 30 metres long
3. 1 Adaptor cable SUBCONN MC IL 5 F --> SUBCONN IL 2 M for Online-Operations
4. 1 Dummy SUBCONN MC DC 5 F
5. 1 Operation Manual

TECHNICAL DATA

Connector at the Motor Unit: SUBCONN MC BH 5 M with integrated FSK-port and serial port
(replaces the connector SUBCONN BH 2 M of the online version)

Sampling rate: 1 Hz (1 data set per second)

Bytes per data set: 5 to 25 (depending on sensor configuration of the instrument)

Data memory: 16 MByte, sufficient for 180 to 900 hours of continuous recording

Operating temperature: -40 ... +85°C

Power supply: No extra power supply requested. The **OFFLINE-SET** is powered by the 3 Lithium batteries type DURACELL DL 123 A / 3V (or equivalent) of the Motor Unit.

OPERATING MODES

A Multi Water Sampler Slimline with integrated **OFFLINE-SET** can be operated as a full **ONLINE-SYSTEM** as well as full **OFFLINE-SYSTEM**.

Serial port for direct communication with the PC and FSK-port for communication with the Deck Command Unit are both integrated into the connector SUBCONN MC BH 5 M (mounted to the front lid of the Motor Unit).

The selection of the operating mode is made **BEFORE SWITCHING ON THE MOTOR UNIT** by connecting:

- a) the Deck Command Unit via adaptor cable MC IL 5 F --> IL 2 M to the connector MC BH 5 M of the Motor Unit to operate the Multi Water Sampler Slimline in **ONLINE-MODE** for **ONLINE-OPERATIONS**.
- b) the PC via programming cable MC IL 5 F --> Sub-D 9 pin directly to the connector MC BH 5 M of the Motor Unit to prepare an **OFFLINE-OPERATION** resp. to transfer stored data from the Motor Unit to the PC after an **OFFLINE-OPERATION**.
- c) the dummy MC DC 5 F directly to the connector MC BH 5 M of the Motor Unit to carry out an **OFFLINE-OPERATION** according to the pre-programmed activation pressures of the water dampers.

Please note that the Multi Water Sampler Slimline automatically starts an OFFLINE-OPERATION when switched on with neither adaptor cable MC IL 5 F --> IL 2 M nor programming cable connected and thus starts to append measuring data to existing measuring data inside the data memory!

The measuring data of a previous OFFLINE-OPERATION will not be deleted.

The Multi Water Sampler Slimline will stop recording measuring data automatically when the data memory is completely used.

ONLINE-OPERATIONS

1. To carry out **ONLINE-OPERATIONS** connect the adaptor cable MC IL 5 F --> IL 2 M to the connector MC BH 5 M of the Motor Unit and secure it with its locking sleeve before switching on the system.
2. Carry out a SECOND TEST RUN according to the OPERATION MANUAL of the **MULTI WATER SAMPLER SLIMLINE**. The **MULTI WATER SAMPLER SLIMLINE** can be controlled from the Deck Command Unit as well as from the PC by using the data acquisition software **OceanLab** (see MANUAL of **OceanLab**).
3. Switch off the Motor Unit.
4. To prepare the **MULTI WATER SAMPLER SLIMLINE** for operations please refer to chapter PREPARATION FOR OPERATION of the OPERATION MANUAL of the **MULTI WATER SAMPLER SLIMLINE**.
5. The operation is carried out according to chapter OPERATION of the OPERATION MANUAL of the **MULTI WATER SAMPLER SLIMLINE**.

OFFLINE-OPERATIONS

1. To prepare **OFFLINE-OPERATIONS** connect the programming cable MC IL 5 F --> Sub-D 9 pin to the connector MC BH 5 M of the Motor Unit before switching it on.
2. Connect the programming cable to the serial COM-port of the PC.
3. Switch on the Motor Unit.
4. Start OceanLab.
5. Carry out a SECOND TEST RUN according to the OPERATION MANUAL of the **MULTI WATER SAMPLER SLIMLINE** by controlling the system from the **MONITORING MODE** of the data acquisition software **OceanLab** (see MANUAL of **OceanLab**).
During the SECOND TEST RUN check the battery voltage inside the **MONITORING MODE** of **OceanLab**. The batteries of the Motor Unit should be changed when the battery voltage falls below 7 V whilst the motor of the Motor Unit is active.
Switch off the Motor Unit before disconnecting the Battery Housing!
6. Switch off the Motor Unit.
7. Before programming make sure that the red release block of the **MULTI WATER SAMPLER SLIMLINE** is in start position (between slit no. 1 and slit no. 6).
8. After approx. 2 seconds switch on the Motor Unit.
9. Inside **OceanLab** enter the **CONTROLLING MODE**.
10. Select **BOTTLE** from the list of implements and make sure that the **MOTOR COUNTER** indicates **0** (zero).
11. Select **MEMORY** from the list of implements and make sure that the remaining capacity of the data memory is sufficient for the next operation.
12. When the remaining capacity of the data memory is not sufficient click on button **CLEAR MEMORY** to clear the data memory of the Motor Unit.

THIS FUNCTION IS IRREVERSIBLE!

Please note that the MULTI WATER SAMPLER SLIMLINE automatically starts an OFFLINE-OPERATION when switched on with neither adaptor cable MC IL 5 F --> IL 2M nor programming cable connected and thus creates a new data file inside the data memory!

The measuring data of a previous OFFLINE-OPERATION will not be deleted.

The MULTI WATER SAMPLER SLIMLINE will stop recording measuring data automatically when the data memory is completely used.

13. Select **PRESSURE PROGRAMMING** inside the components window to get access to the list of programmable activating pressures.
14. Enter the **UNLOCK PRESSURE** in the format:
nnnn.n (nnnn.n: pressure in dbar)
The Motor Unit will be disabled during lowering the **MULTI WATER SAMPLER SLIMLINE** into the water until reaching the **UNLOCK PRESSURE** (but will continuously record measuring data). Thus the **UNLOCK PRESSURE** should be min. 20 dbar greater than the closing pressure of the first water sampler.

-
15. Enter a list of **ACTIVATING PRESSURES** in the format:
mmmm.m (mmmm.m: pressure in dbar)
The **ACTIVATING PRESSURES** must be in **descending** order. That means that the first water sampler will be closed in the greatest scheduled depth. The closing pressure for the first water sampler **must** be smaller than the **UNLOCK PRESSURE**.
 16. Click on button **SEND TO INSTRUMENT** to check the programming data and to transfer them into the Motor Unit.
 17. Select **REAL TIME CLOCK** inside the components window and adjust the clock inside the Motor Unit if necessary.
 18. Switch off the Motor Unit.
 19. Remove the programming cable (MC IL 5 F --> Sub-D 9 pin) from the Motor Unit.
 29. Slightly grease the pins of the connector MC BH 5 M at the Motor Unit with pin lubricant.
 21. Place the dummy MC DC 5 F on the connector MC BH 5 M at the Motor Unit and secure it with its locking sleeve.
 22. To prepare the **MULTI WATER SAMPLER SLIMLINE** mechanically for the operation please refer to chapter OPERATION of the OPERATION MANUAL of the **MULTI WATER SAMPLER SLIMLINE**.
 23. To avoid misfunctions make sure that the dummy SUBCONN MC DC 5 F is placed on the connector SUBCONN MC BH 5 M at the Motor Unit and is secured with a locking sleeve.
 24. The operation is carried out according to chapter OPERATION of the OPERATION MANUAL of the **MULTI WATER SAMPLER SLIMLINE**. Please make sure to pass the programmed UNLOCK PRESSURE during lowering the **MULTI WATER SAMPLER SLIMLINE** to unlock the Motor Unit. The activation of the water samplers will be carried out automatically during heaving in the programmed pressure steps.
 25. Just before deployment the **MULTI WATER SAMPLER SLIMLINE** is started by setting the lever switch at the outside of the Motor Unit into position I.
 26. When the Underwater Unit is back on board switch off the Motor Unit.
 27. To prepare the data transfer of the stored data to the PC connect the programming cable MC IL 5 F --> Sub-D 9 pin to the connector MC BH 5 M of the Motor Unit before switching it on.
 28. Connect the programming cable to the serial COM-port of the PC.
 29. Switch on the Motor Unit.
 30. Start **OceanLab**.
 31. Inside **OceanLab** enter the **CONTROLLING MODE**.
 32. Select **MEMORY** inside the components window.
 33. All data files stored inside the instruments data memory are available inside the **FILE TABLE**. Each file is marked with date and time of session start, file size and a green or red dot. A green dot indicates that the file has already been stored at the PC. A red dot indicates that the file has not yet been stored at the PC.
 34. Use tick boxes to select data files for data transfer to the PC.

-
35. Click on button **READ SELECTED FILES** to transfer the stored data from the Underwater Unit to a disk file.
 36. Inside the toolbar of **OceanLab** click on button **STOP SESSION** to disconnect from the instrument.
 37. Switch off the Motor Unit.
 38. Use the **MONITORING MODE** of **OceanLab** to evaluate the data files(s).
 39. To avoid corrosion at the contacts slightly grease the pins of the connector MC BH 5 M at the Motor Unit with pin lubricant and protect it with the dummy MC DC 5 F.

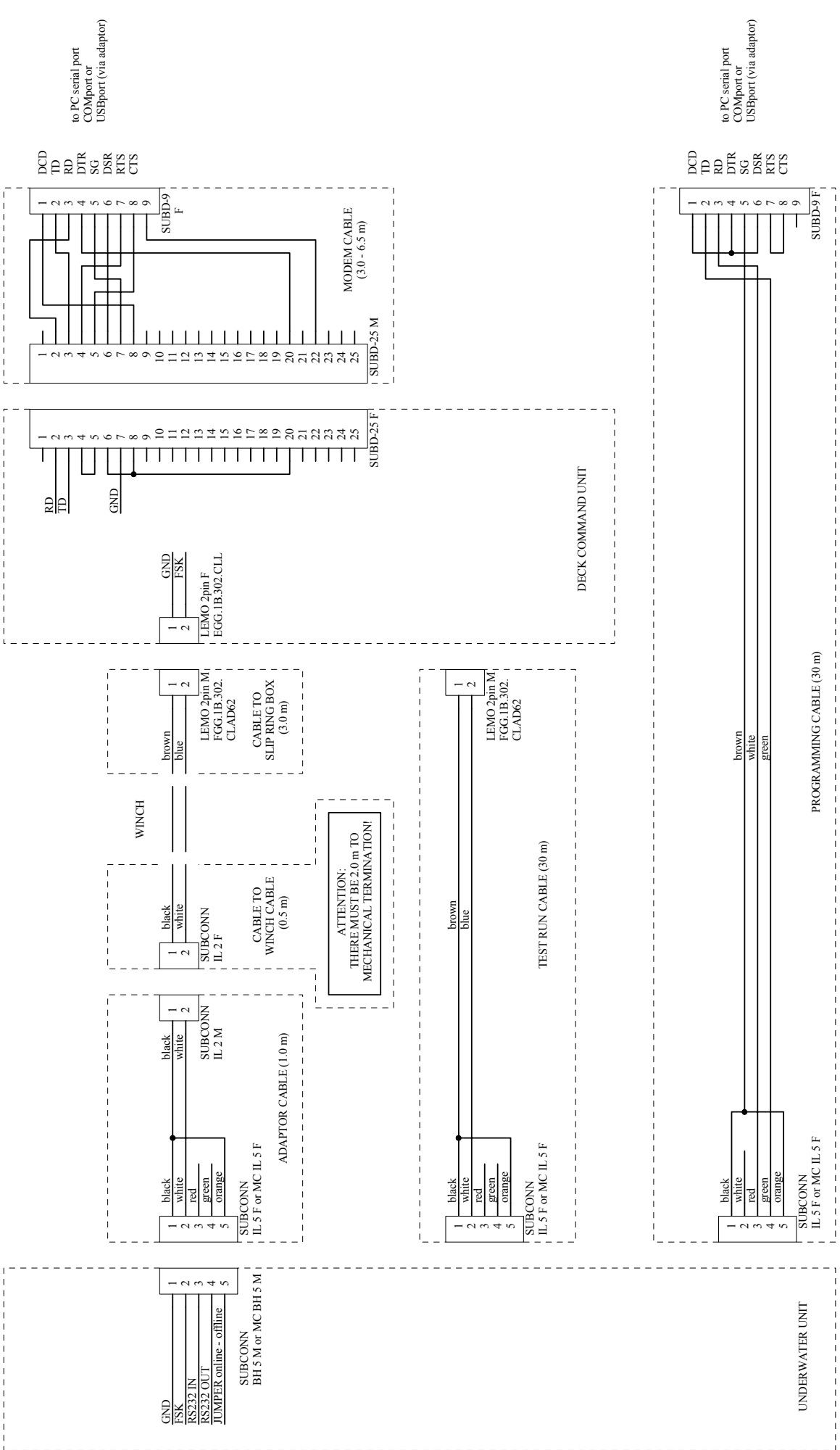

to PC serial port
COMport or
USBport (via adaptor)

to PC serial port
COMport or
USBport (via adaptor)

Datum:	Name:	Katalog-Nr.	Gruppe	Teil
21.04.2015	Plohn			
UU_1_29.SCH		circuit diagram STANDARD UNDERWATER UNIT PC serial ports / FSK-ports / online - offline		

