

Hidden SIMS

Analytical Secondary Ion Mass
Spectrometry Products

Introduction to SIMS

Sputter Erosion of the Specimen

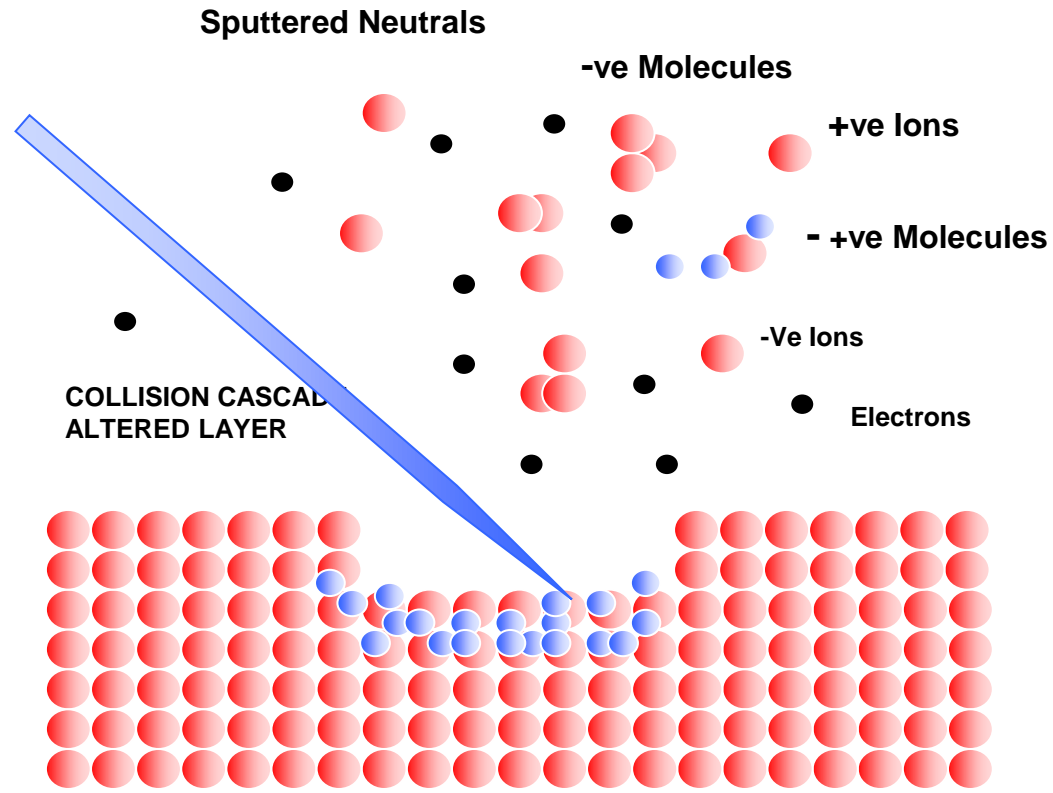

Introduction to SIMS

Sputter Erosion of the Specimen

Static SIMS

- Very low ion dose ($\sim 1 \text{E}12 \text{ ions cm}^{-2}$) gives surface specific measurement.
- Ideal for investigation of contamination, oxidation and monolayer coatings.

Dynamic SIMS

- Higher ion dose erodes surface exposing deeper material.
- Monitoring mass resolved ion signals results in depth profile.
- Ideal for investigation of impurities (dopants) and layer structures

Introduction to SIMS – sputter erosion of the specimen

Scanning the beam across the sample

- Flat bottom crater
- Imaging – collect data as a function of position
- Gating, only collect data when the beam is in the central flat part of the crater for high dynamic range depth profiles.

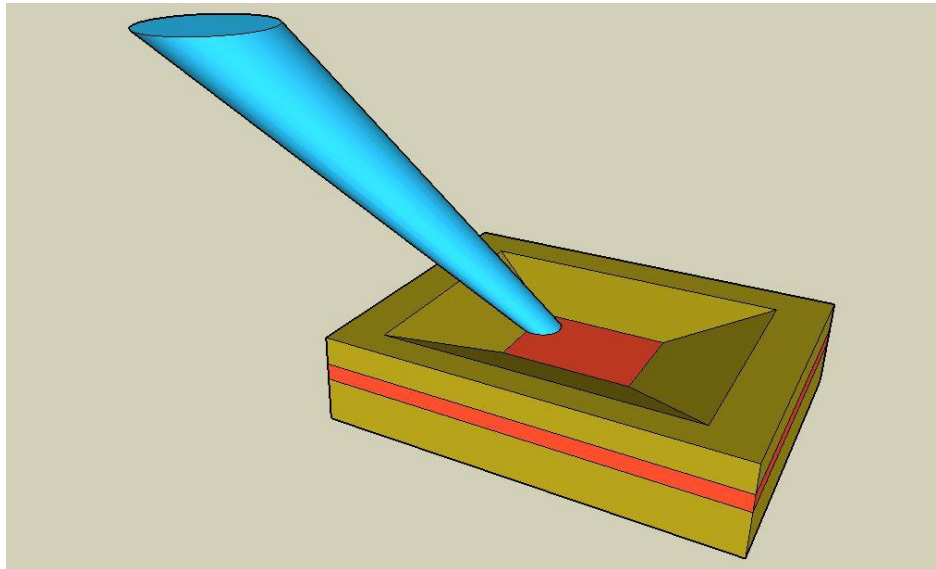

Introduction to SIMS

Anatomy of a Depth Profile

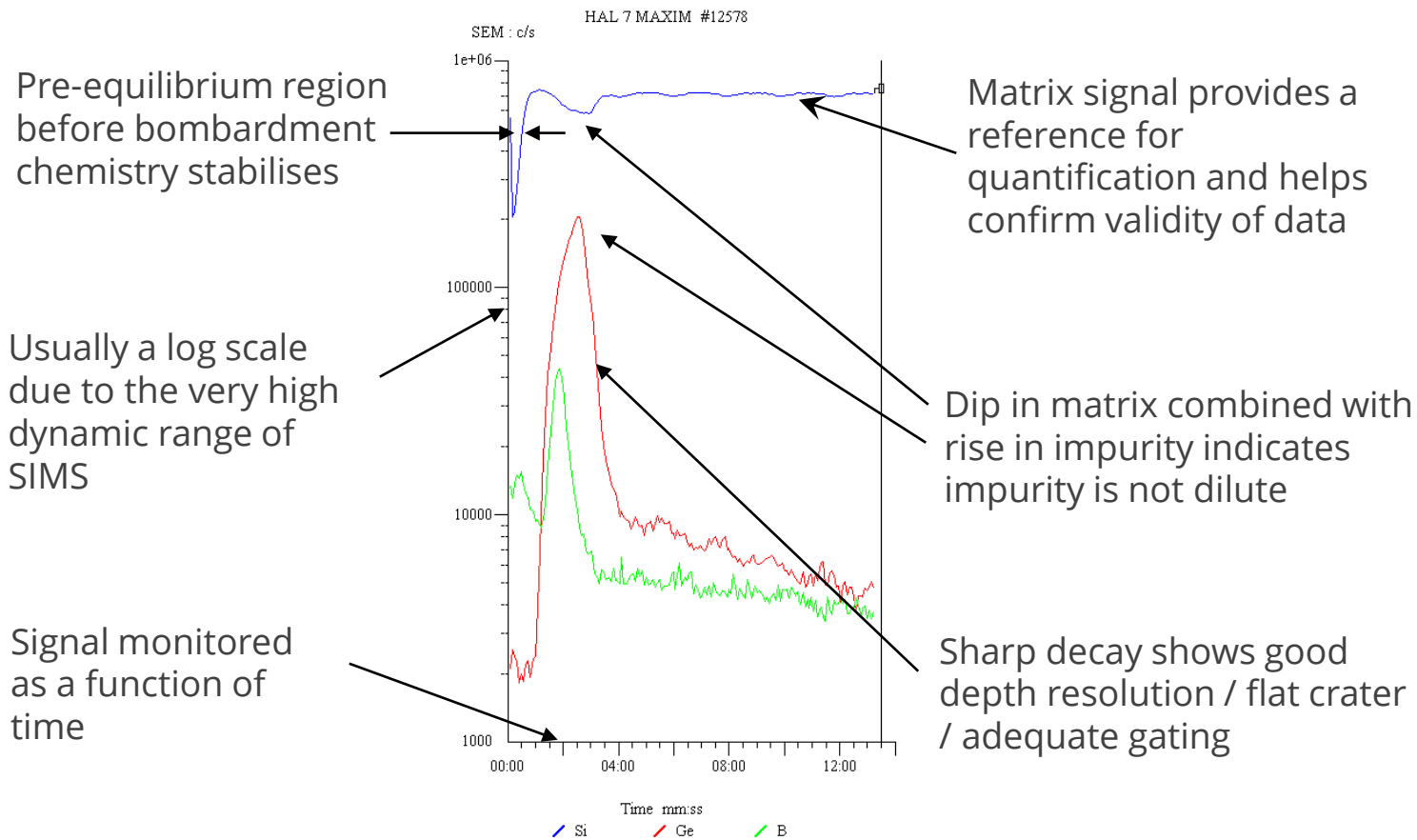

Introduction to SIMS

Primary ion beams

The probability of ion emission is affected greatly by the sample chemistry.

As the ion beam species becomes incorporated into the specimen it can be used to modify the surface chemistry and enhance probability of ionised emission.

- Oxygen enhances ionisation of electropositive elements
 - many metals and semiconductor matrix species
- Caesium enhances ionisation of electronegative elements
 - halogens, many contamination species, some metals
- Caesium can also be used to collect secondary ion cluster
 - (MCs⁺) of most species (M) at lower sensitivity but better linearity at high concentration.

Introduction to SIMS

Relative Ion Yields - Positive SIMS Oxygen Primary Ions

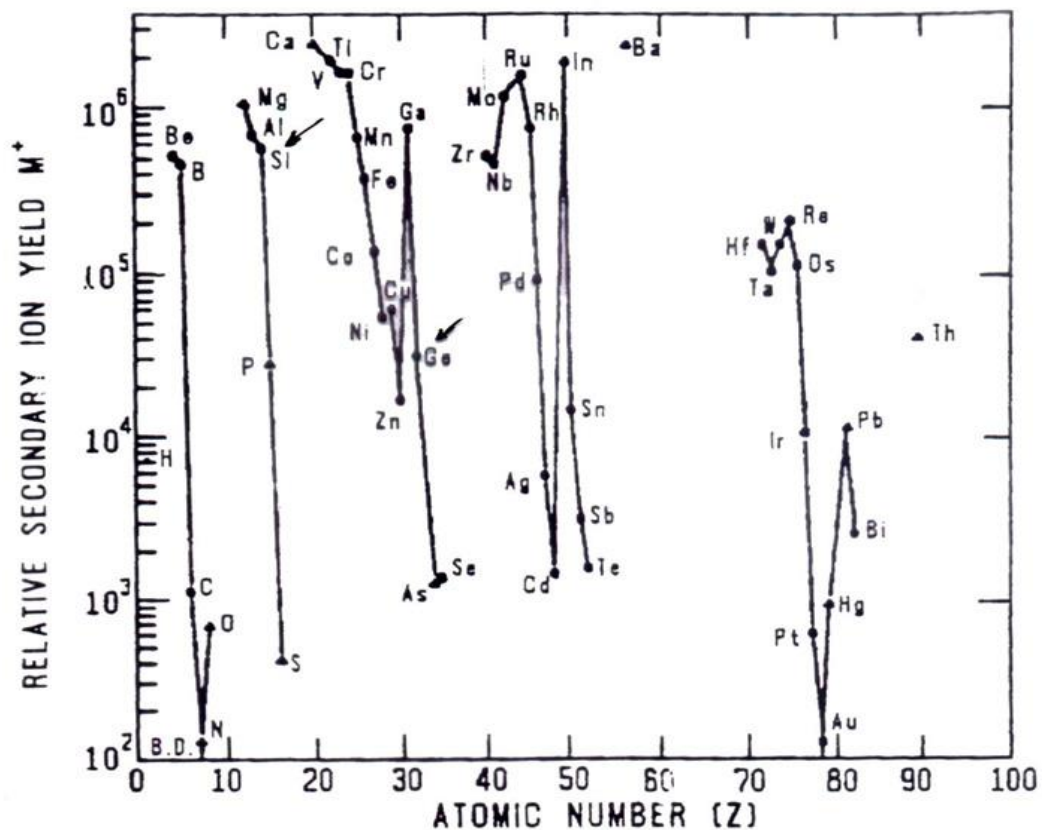

SIMS Handbook ed : Wilson R.G.; Stevie, F.A.; Magee, C.W.;
John Wiley & Sons Inc. NY 1989

Introduction to SIMS

Relative Ion Yields - Negative SIMS Caesium Primary Ions

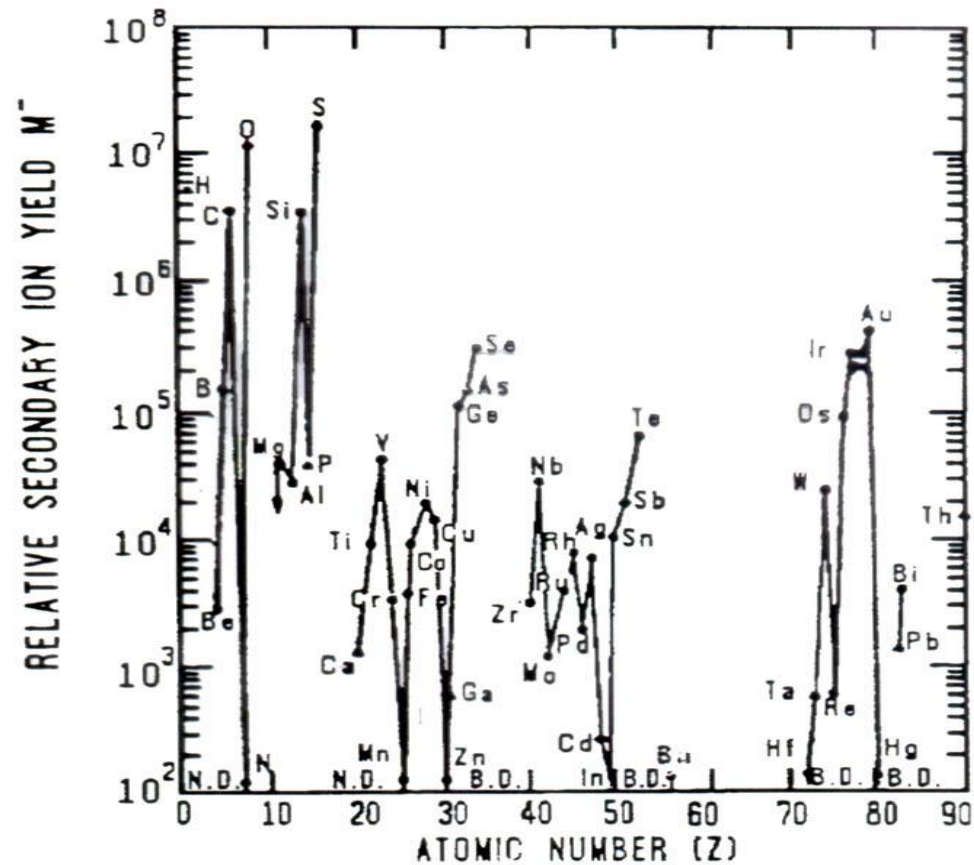

SIMS Handbook ed : Wilson R.G.; Stevie, F.A.; Magee, C.W.;
John Wiley & Sons Inc. NY 1989

Introduction to SIMS

Recommended Primary Ions

Element	Ip	Ion	Notes
H	Cs	H-	2H if implant
He	O2	He+	No for HeCs+
Li	O2	Li+	
Be	O2	Be+	HMR in AlGaAs (Al3+)
B	O2	B+	BSi- also works
C	Cs	C-	CM- can give better DL
N	Cs	NM-	use N-15 if implanting
O	Cs	O-	use O-18 if implanting
F	Cs	F-	
Ne	O2	Ne+	or NeCs+
Na	O2	Na+	
Mg	O2	Mg+	
Al	O2	Al+	
Si	Cs	Si-	
P	Cs	P-	or P+ with O2 (HMR in Si)
S	Cs	S-	or S+ with O2 (HMR in Si)
Cl	Cs	Cl-	
Ar	O2	Ar+	or ArCs-
K	O2	K+	
Ca	O2	Ca+	
Sc	O2	Sc+	
Ti	O2	Ti+	or Ti- with Cs
V	O2	V+	or V- with Cs
Cr	O2	Cr+	
Mn	O2	Mn+	no Mn- ion
Fe	O2	Fe+	HMR in Si. Fe54 for implant
Co	O2	Co+	HMR in Si
Ni	O2	Ni+	or Ni- with Cs. HMR in Si
Cu	O2	Cu+	or Cu- with Cs.
Zn	O2	Zn+	or ZnCs+
Ga	O2	Ga+	
Ge	Cs	Ge-	or 70Ge+ with O2
As	Cs	AsM-	or 75As- HMR in Si
Se	Cs	Se-	
Br	Cs	Br-	

Element	Ip	Ion	Notes
Kr	O2	Kr+	or KrCs+ with Cs
Rb	O2	Rb+	
Sr	O2	Sr+	
Y	O2	Y+	
Zr	O2	Zr+	
Nb	O2	Nb+	
Mo	O2	Mo+	
Ru	O2	Ru+	or Ru- with Cs
Rh	O2	Rh+	or Rh- with Cs
Pd	O2	Pd+	or Pd- with Cs
Ag	O2	Ag+	or Ag- with Cs
Cd	O2	Cd+	or CdCs+. No Cd- ion
In	O2	In+	
Sn	O2	Sn+	or Sn- with Cs
Sb	Cs	Sb-	or SbM- or Sb+ with O2.
Te	Cs	Te-	
I	Cs	I-	
Xe	O2	Xe+	no XeCs+
Cs	O2	Cs+	
Ba	O2	Ba+	HMR in GaAs
La	O2	La+	all La rare earths as La
Hf	O2	Hf+	no Hf- ion
Ta	O2	Ta+	
W	O2	W+	
Re	O2	Re+	
Os	Cs	Os-	or Os+ with O2
Ir	Cs	Ir-	
Pt	Cs	Pt-	
Au	Cs	Au-	
Hg	O2	Hg+	or HgCs+. no Hg- ion
Tl	O2	Tl+	
Pb	O2	Pb+	HMR in GaAs
Bi	Cs	Bi-	or BiM- or Bi+ with O2
Th	O2	Th+	
U	O2	U+	

Hidden SIMS Products – Ion Guns

IG20 Gas Ion Gun

- 1-5 keV, 0.5 μ A, 100 μ m (50 μ m imaging)
- Reliable, long life, electron impact ion source
- Integral bend to remove neutral particles
- May be used with reactive and inert gases (e.g. H, He, O, N, Ar, Xe, air)
- Differential pumping to preserve chamber UHV
- Bakeable to 250°C
- Mounts on CF35

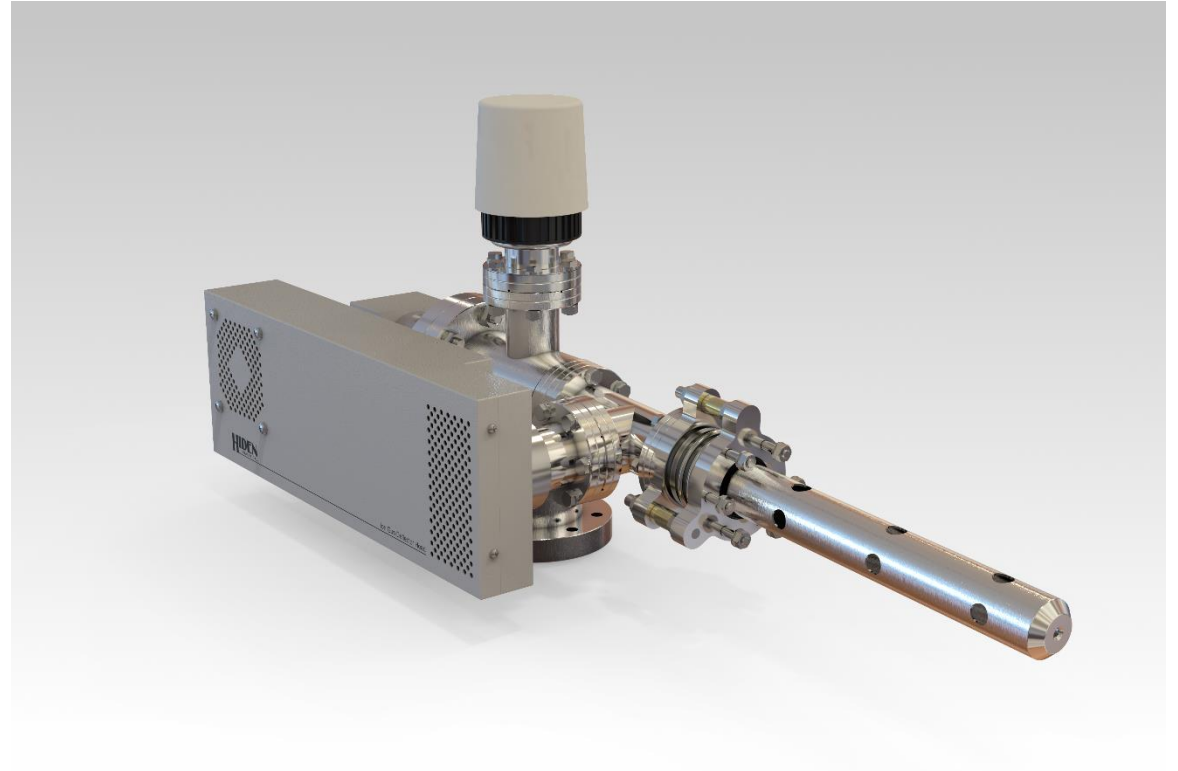

Hidden SIMS Products – Ion Guns

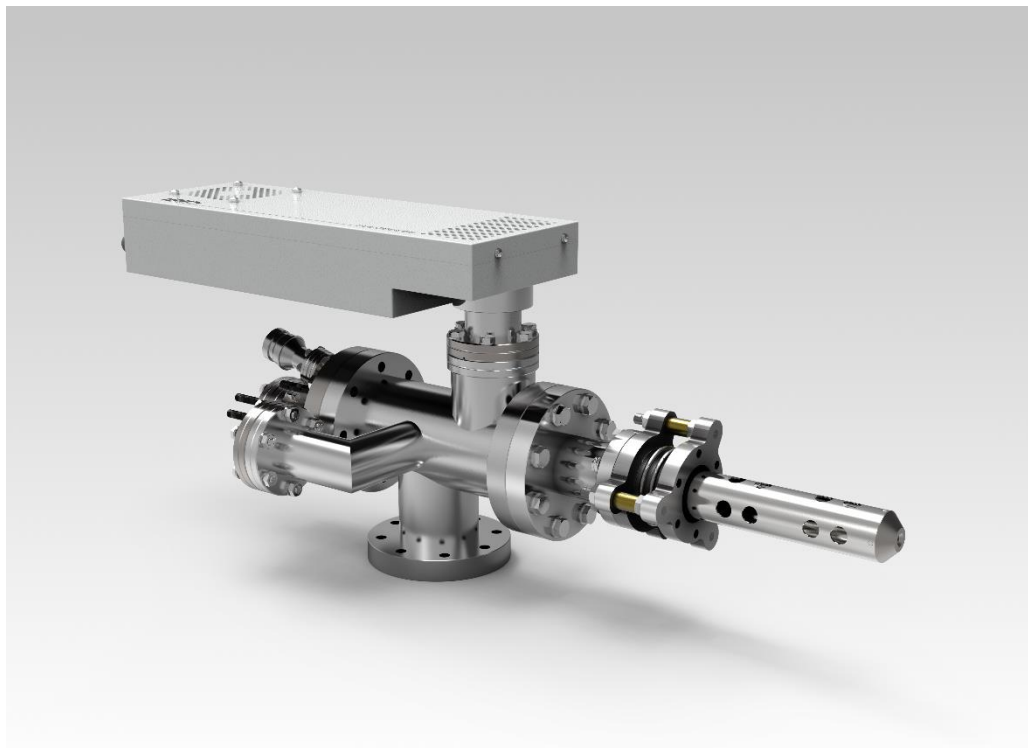

IG5C Caesium Ion Gun

- 1-5 keV, 150nA, 80 μ m (20 μ m imaging)
- Miniature low power Cs Ion source (~8W), long life, easy replacement.
- Air stable
- Double bend to remove neutral particles
- Differential pumping to preserve chamber UHV
- Bakeable to 250°C
- Mounts on CF35

Hidden SIMS Products – Ion Guns

Ion Gun Control

PC controlled

Settings can be saved and recalled

Automatic ion source warm up / cool down

EHT ramp rate control

Gun diagnostics

Connect via TCP/IP, USB or serial

Upgradeable software and firmware

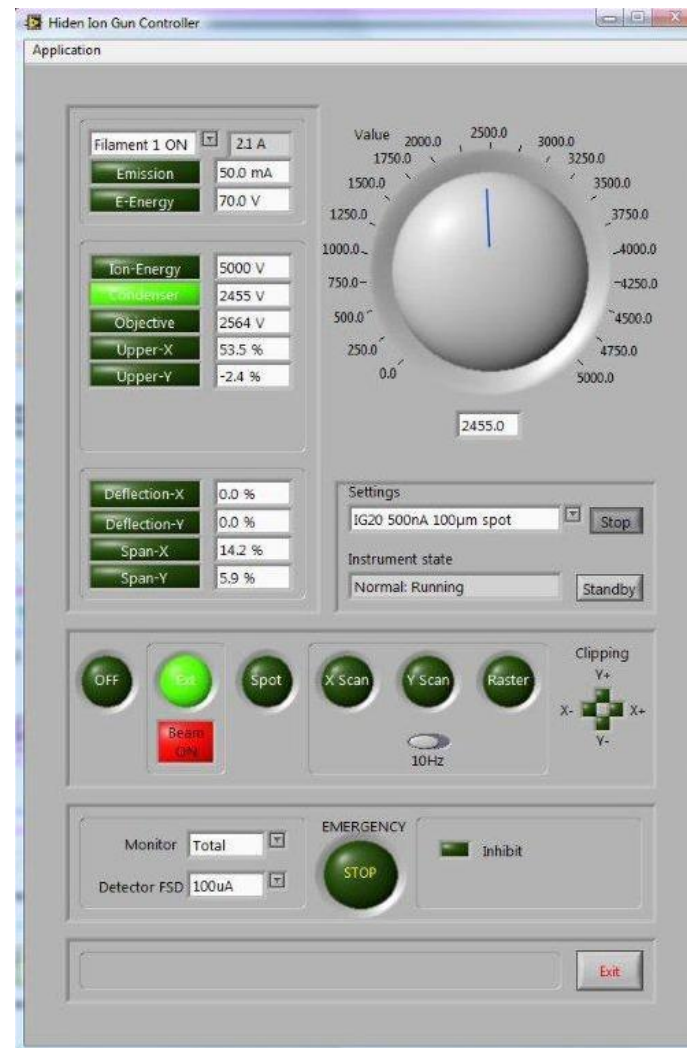

Hidden SIMS Products – Spectrometers

MAXIM – High Performance SIMS and SNMS

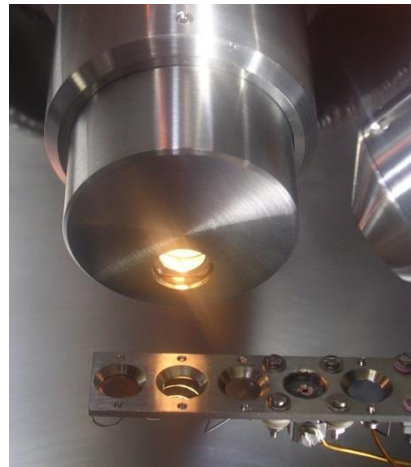

Easy to change filament for SNMS

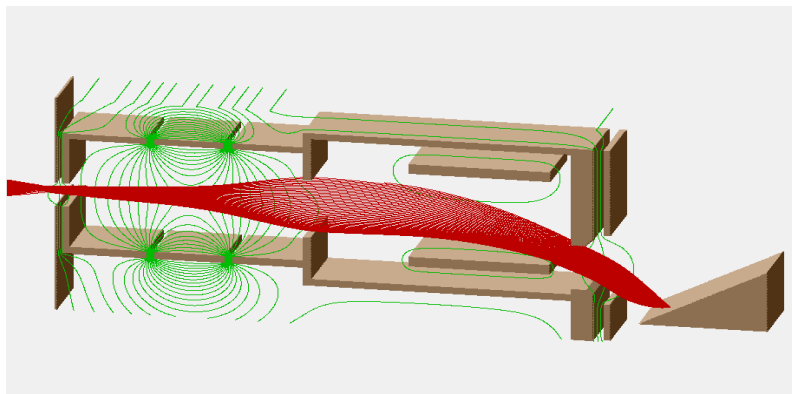

Off-axis collection

Hidden SIMS Workstation



- 3D imaging
- Depth profiling
- Static SIMS
- SNMS

- MAXIM SIMS/SNMS
- Oxygen Ion Gun
- Cs Ion Gun
- Electron charge compensation gun
- O₂ gas jet
- Loadlock degas heater
- Large area near sample cryotrap
- UHV – bakeable
- Large sample holder
- Normal incidence camera

- Single phase 2500 W
- No compressed air
- Air cooled
- Remote backing pump option
- All dry pumps

Hidden SIMS Workstation - sample mounting

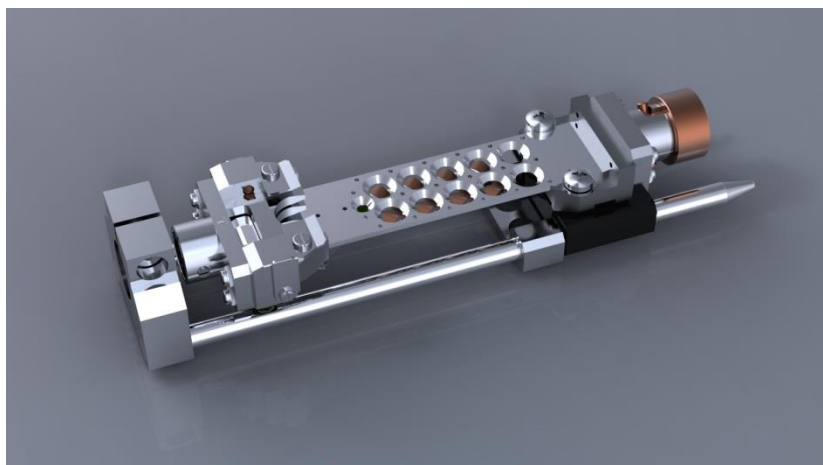
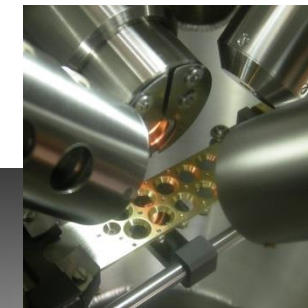
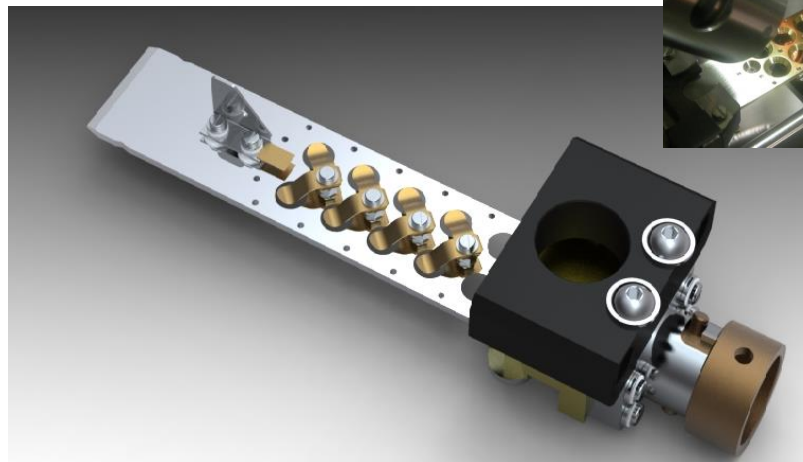
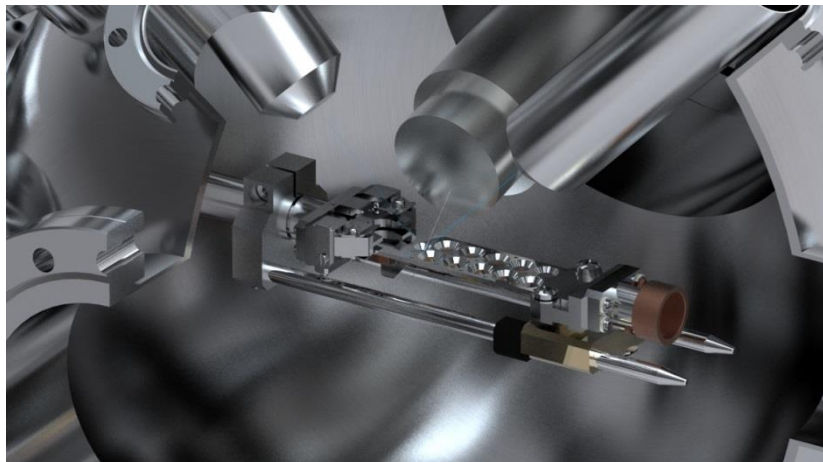

- Samples mount from the underside .
- The upper surface is always in the correct plane for analysis.
- Maximum sample thickness 10mm
- Maximum size to load 40 x 40mm
- Easily customisable sample bar
- Spring clip and screws – no adhesive
- Sample bar carries Faraday cup for beam set-up
- Positive bayonet connection and guidance forks make transfer robust and reliable.

Hidden SIMS Workstation - loadlock sample heater

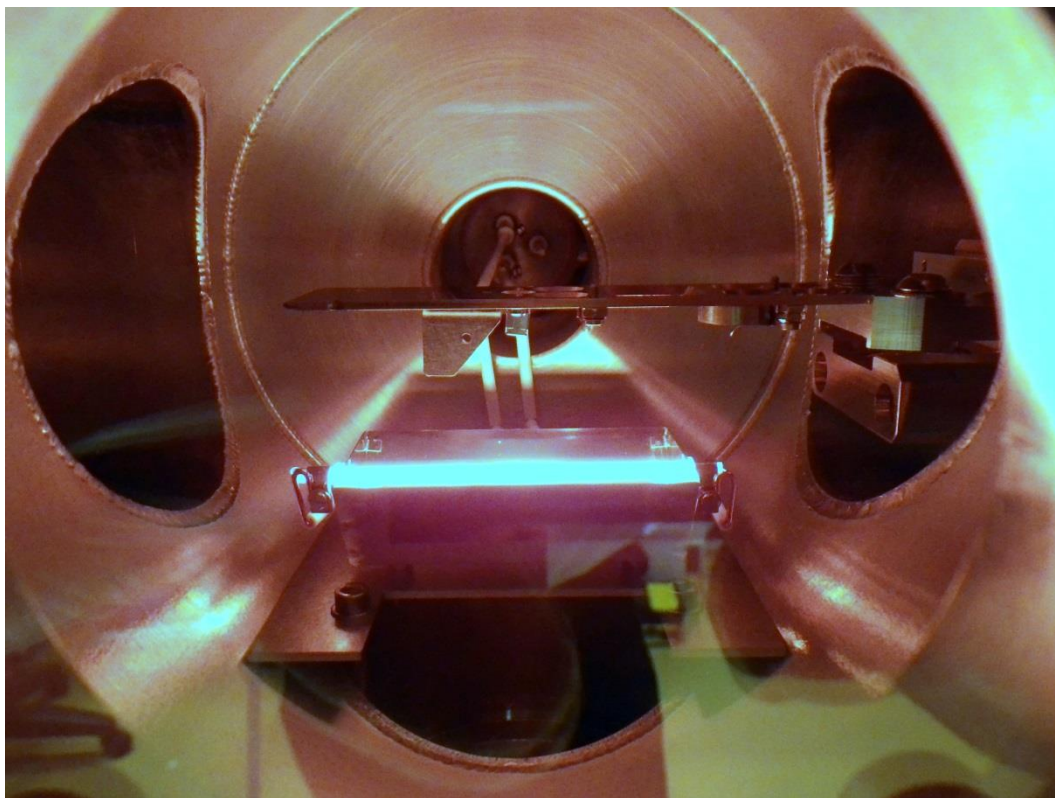

Infra-red sample heating in loadlock

- High purity heater
- Heating from underside (clean top surface)
- Non-contact infra-red
- Uniform heating

- Degas of adsorbed water vapour and volatile compounds.
- Reduced background of hydrogen, oxygen and carbon.
- Preserves UHV environment.

SIMS Workstation with XPS

The SIMS workstation is designed to be customisable and has spare ports for the fitting of other techniques or devices.

Here the instrument is configured for SIMS, SNMS and XPS with the addition of the SPECS PHOIBOS 150 analyser and dual anode x-ray source.

A rotation drive allows the sample to be positioned at the optimum angle for XPS or to make angularly resolved measurements.

SIMS Workstation family

The Hiden SIMS Workstation is a modular instrument. All members of the family are based around the same components so it is easily upgradeable from the basic *Foundation* to the fully configured *Plus* version.

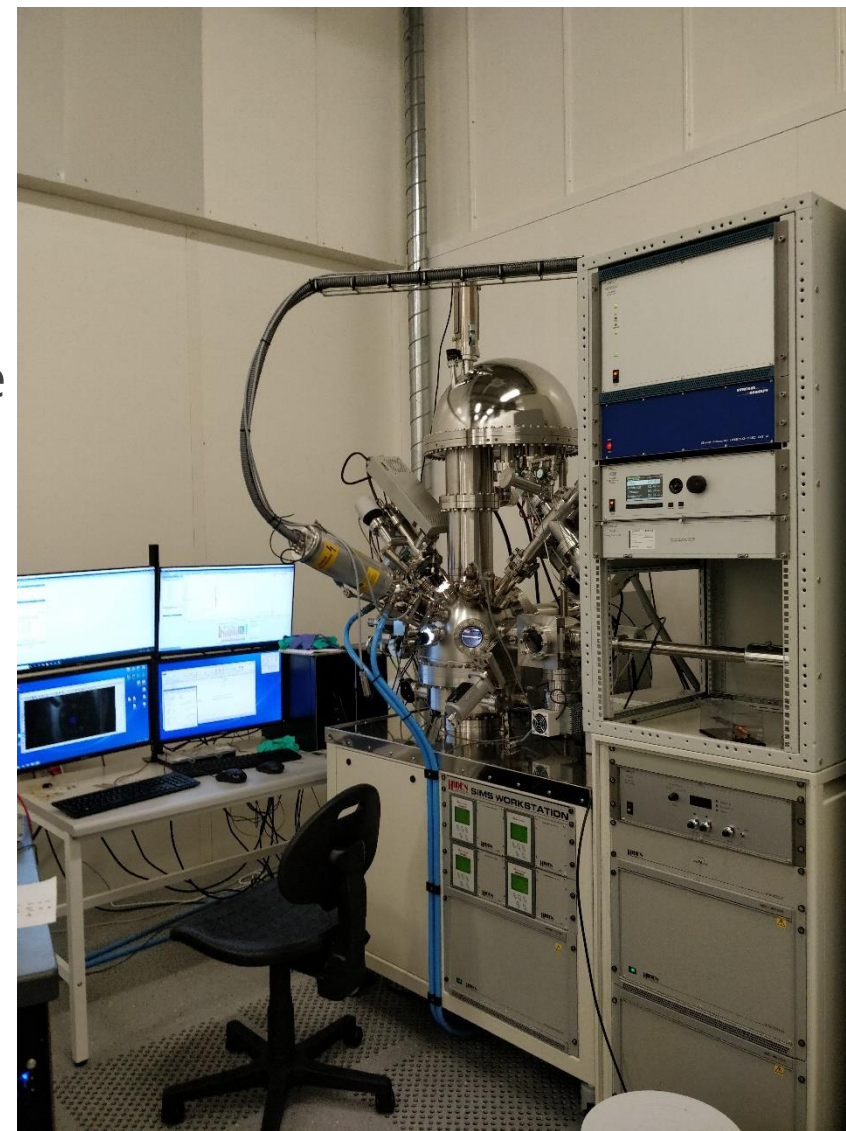

Applications – depth profiling GaAs quantum well structure

Negative secondary ions with 5keV Cs primary ion bombardment

n-GaAs:Si > 10^{19} ~ 0,1 μm

n-AlGaAs:Si > 10^{18} ~ 0,1 μm

p-AlGaAs:C > 5×10^{19} ~ 0,1 μm

GaAs undoped ~ 0,1 μm

InGaAs QW undoped ~ 6 nm

GaAs undoped ~ 0, 2 μm (buffer layer)

n-GaAs - substrate

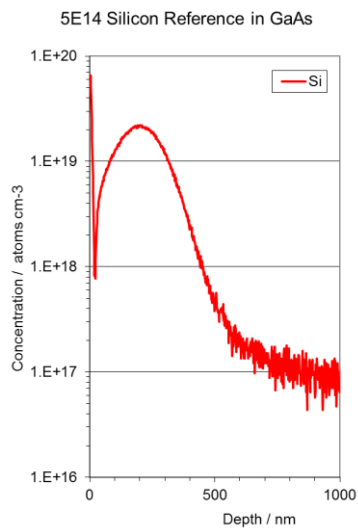

Typical Si detection limit in GaAs $1\text{E}17$ atoms cm^{-3}

Negative SIMS Depth Profile - Raw data

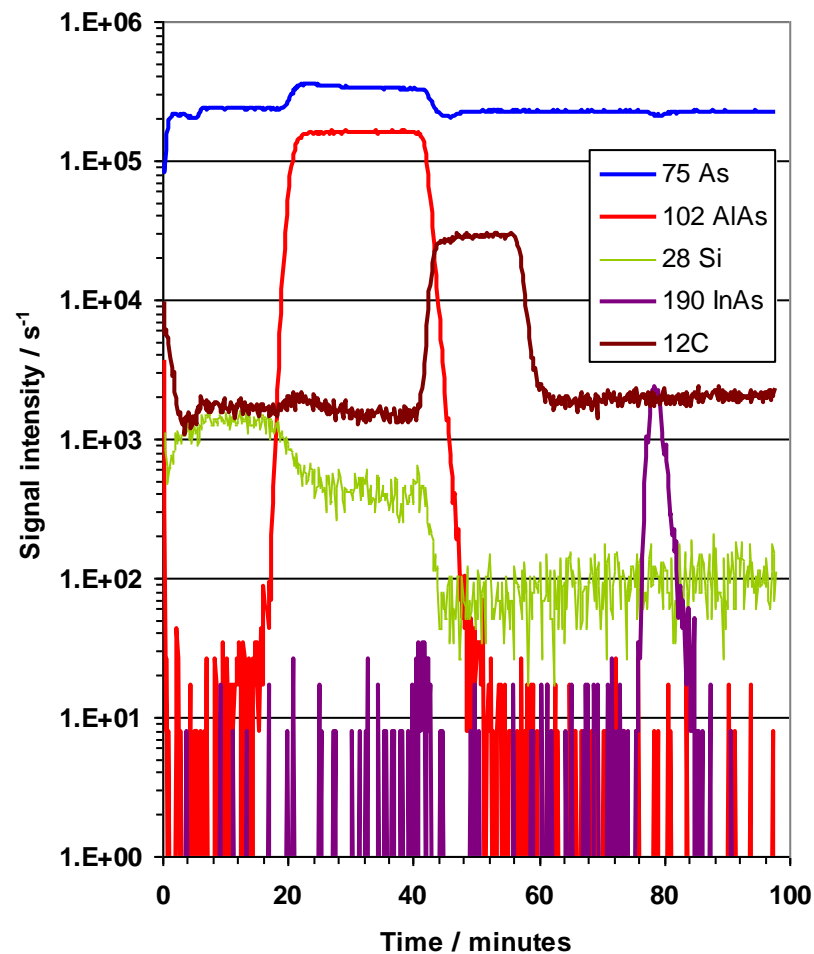

Applications – depth profiling – Ion Implanted reference materials

1E15 Mg implant into Si

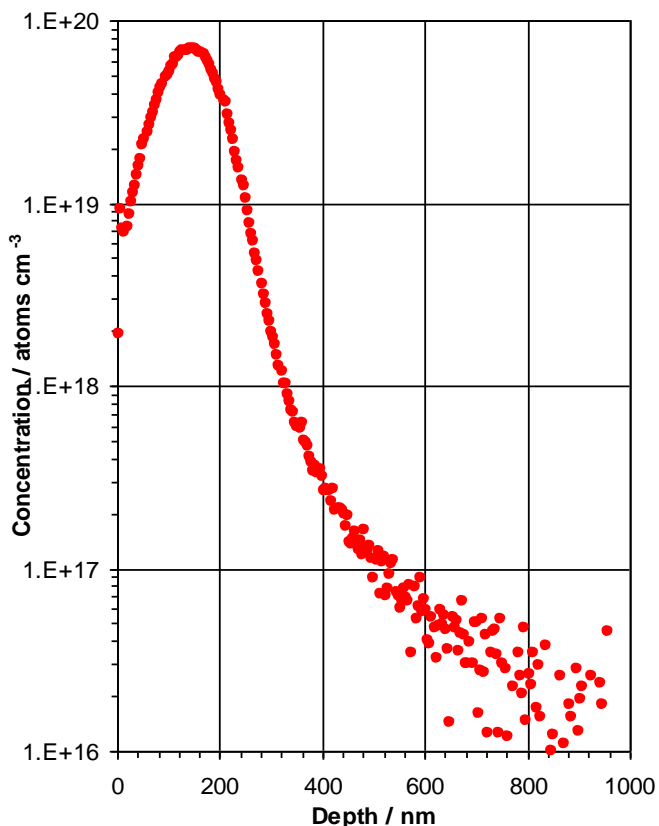

²⁴Mg implant in Si, 10^{15} atoms cm^{-2} analysed using **oxygen primary ions** from IG20 ion gun on SIMS Workstation with MAXIM spectrometer.

5E15 As implant into Si

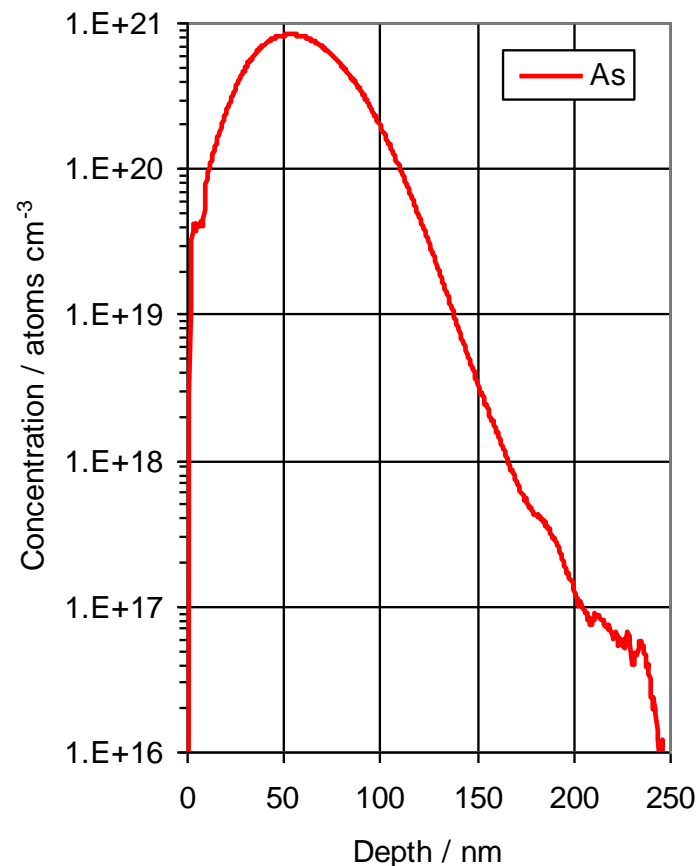

As implant in Si, 5×10^{15} atoms cm^{-2} analysed using 5keV **Cs⁺ primary ions** from IG5C ion gun on SIMS Workstation with MAXIM spectrometer.

Depth Profiling – detection limits

Detection limit depends on:

- Ion yield
- Volume of analyte; large volume = better statistics, lower DL, but bigger crater or depth increment
- Background or interfering signals – use energy offset to reduce molecular interference, ensure clean surfaces and good ion beam shape, UHV and cold trap to reduce effect of residual gas species (H, O).
- Use 3D data collection to optimise gating

Element	Matrix	Detection limit	Comment
		At/cc	
28 Si	GaAs	8E16	Interference signals from AlH in GaAlAs – 5E17 with background subtraction when possible
11 B	Si	2E16	Surface boron contamination gives rise to background, ultimate shown in clean silicon sample.
31 P	Si	7E17	Interference from SiH at mass 31- energy offset and loadlock degas for best result
2 D	Si	1E18	Subtract contribution from natural H for ultimate DL – use cold trap
2 D	W	2E18	Subtract contribution from natural H for ultimate DL – use cold trap
24 Mg	Si	5E16	
75 As	Si	8E16	
9 Be	Si	2E17	

Applications - depth profiling

Depth Profiling Neutron Mirror - 80x 3.6nm Period

A Si/Fe, 80-period, neutron mirror was analysed using normally incident 1.5keV O_2^+ primary ions (100nA) from the IG20 gas gun and detecting secondary ions with the MAXIM SIMS analyser. Although the layers are not fully resolved, the profile shows the thickness to be highly consistent with no loss of depth resolution with depth.

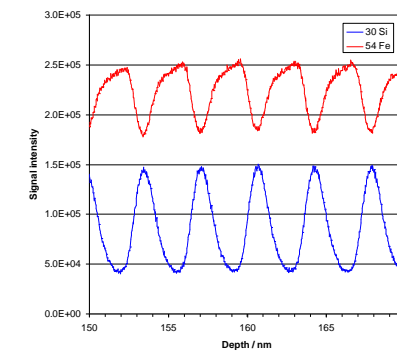
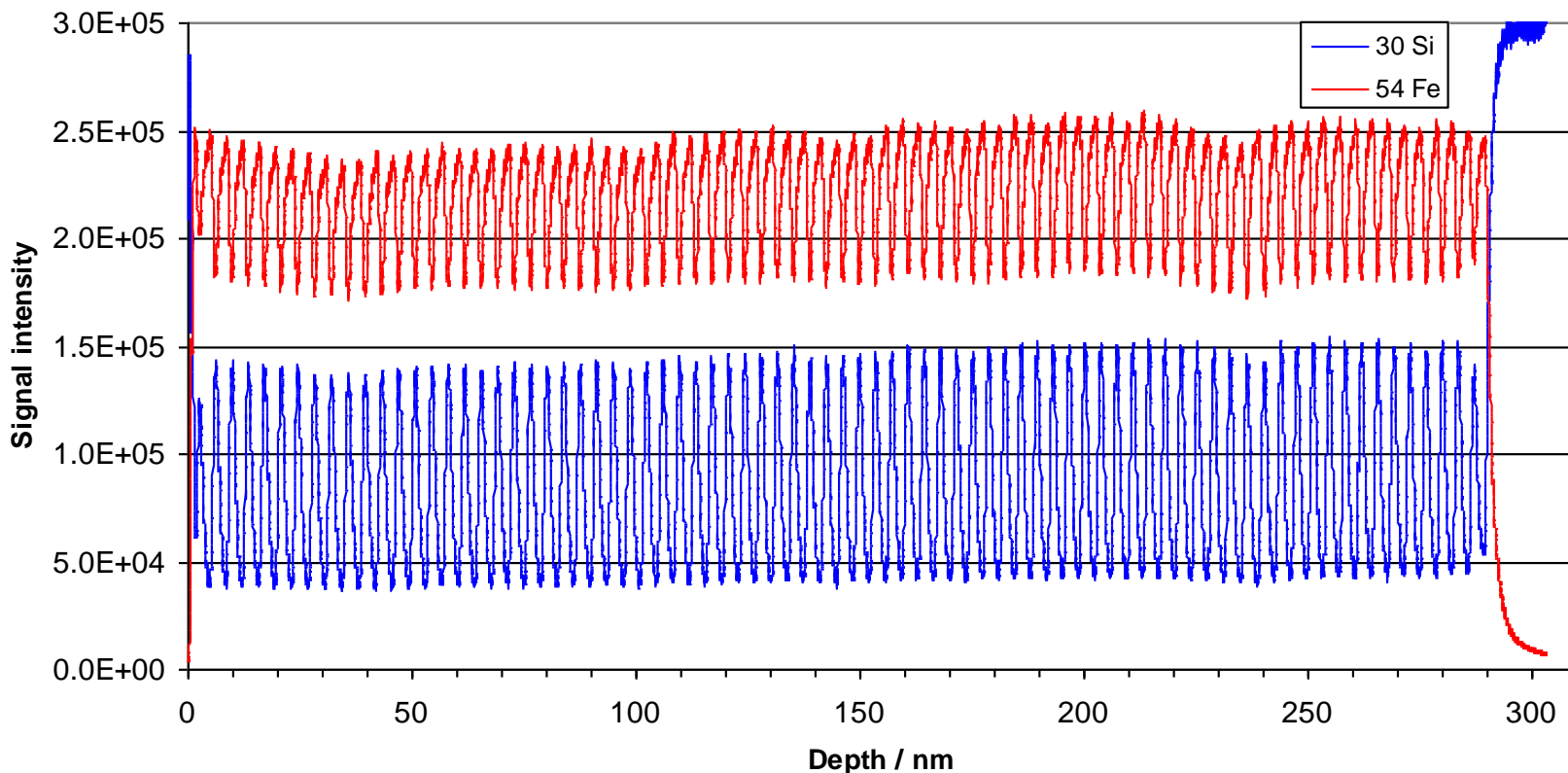

SNMS (sputtered neutral Mass Spectrometry) – Post Ionisation

The generation of ions during sputtering depends very strongly on the chemistry of the sample and primary ion beam and the ion yield can vary non-linearly over orders of magnitude. This 'matrix effect' makes quantification of SIMS data difficult when impurities reach high concentration (> 2%) or when the matrix varies. Sputtered Neutral Mass Spectrometry overcomes this problem and permits quantification in this extremely useful range by separating the ionisation from the sputtering.

- Electron impact cell ionises the sputtered neutral material
- Secondary ions deflected from analyser
- Separating the sputter and ionisation events removes most of the SIMS matrix effect
- Easily quantifies large changes in matrix material
- Detection limit typically <0.1 atomic%
- Excellent for alloy multilayers
- No requirement for matrix matched reference materials
- Neutral species are unaffected by surface charging

SNMS on the MAXIM

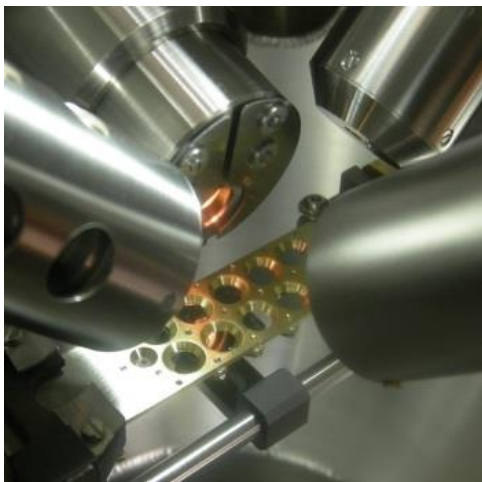

The MAXIM SIMS/SNMS spectrometer has an electron impact ion source fitted close to its entrance. An external deflector plate removes the secondary ions (which generally constitute less than 1% of the sputtered flux) and allows the neutrals to enter the ioniser. Once ionised, the neutrals follow the same path that SIMS ions would have taken.

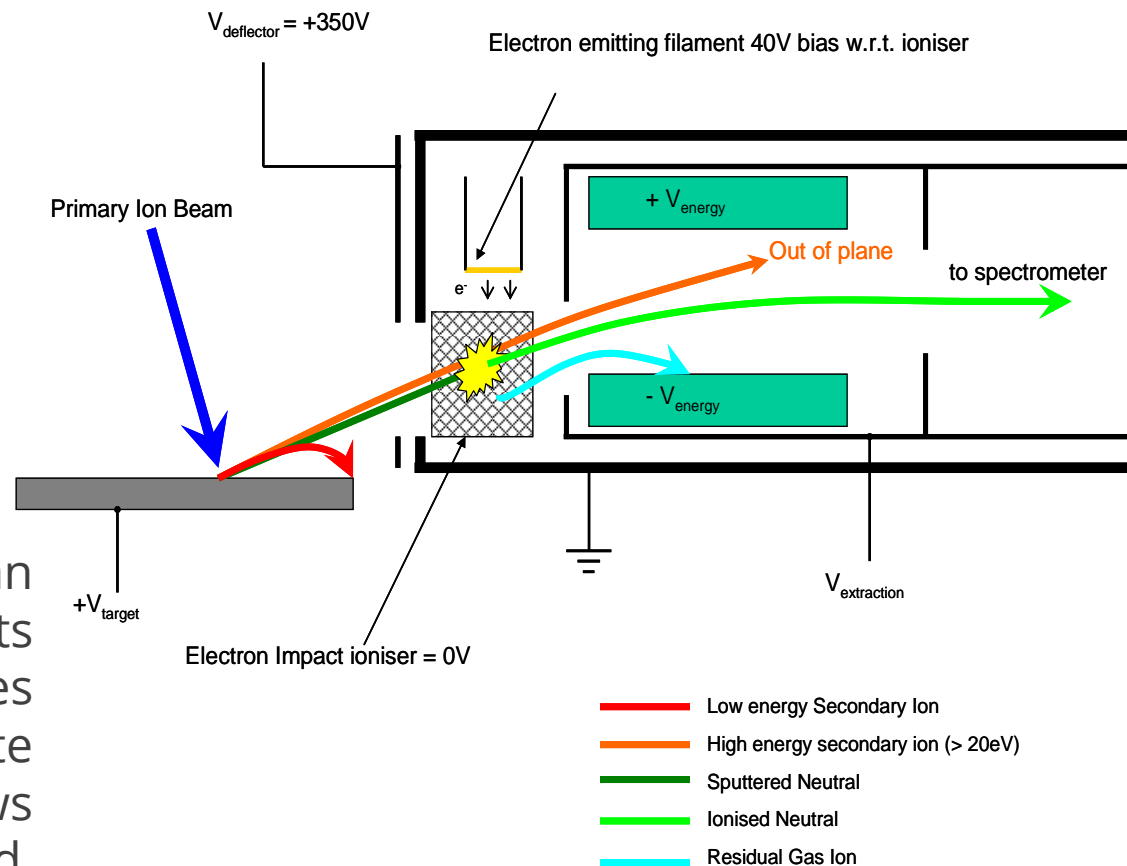

SNMS with appearance energy discrimination

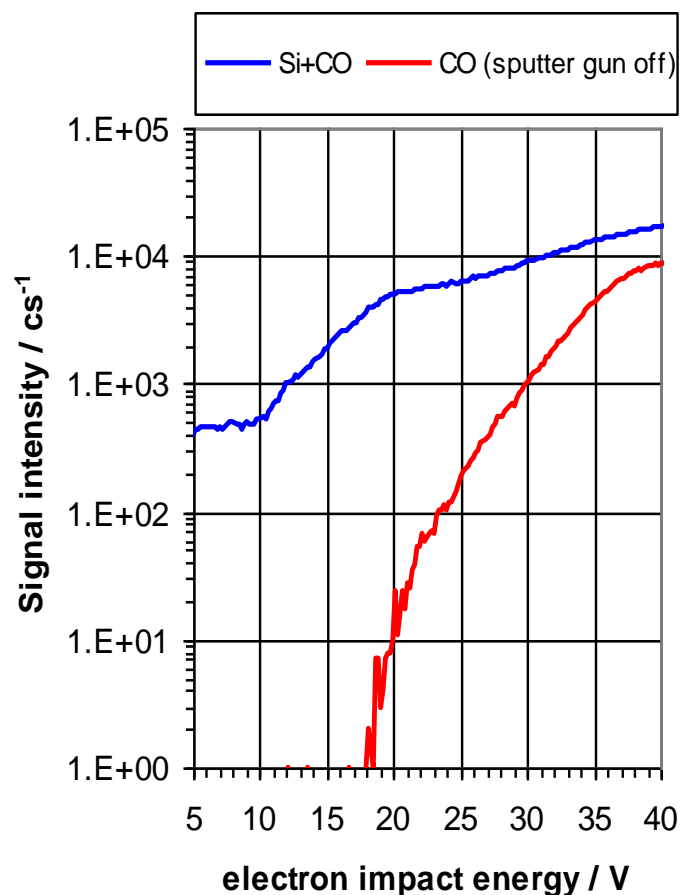

The ability to control the electron impact energy enables some mass interferences to be easily overcome using the ion appearance energy.

For example, CO (mass 28) is a common residual gas constituent and could interfere with the detection of the major isotope of silicon. However, careful choice of the electron energy resolves this problem.

Reducing the electron energy to below 19V prevents ionisation of residual CO, confirmed here by noting the lack of signal with the sputter gun off (red) so with the gun on (blue) the detected signal is from silicon only.

SNMS – Magnetic Storage Materials

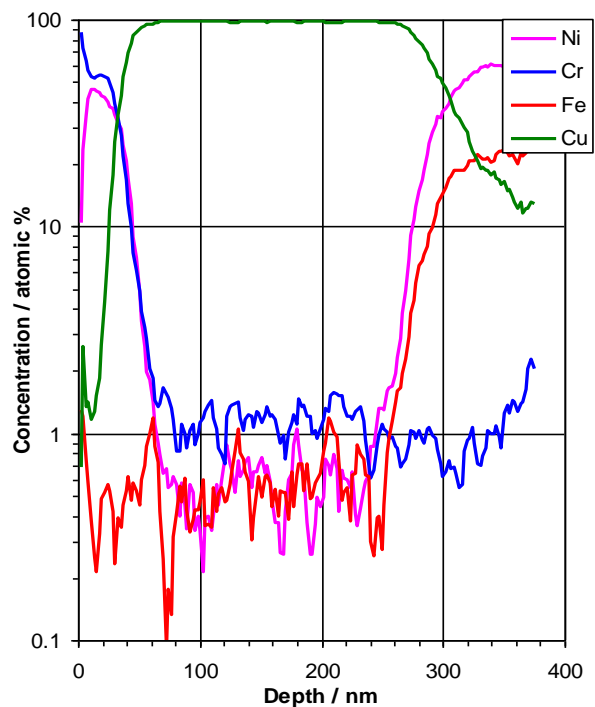

SNMS depth profile of NiCr/Cu/NiFe disk head layer structure, primary ions 5 keV Ar from IG20 ion gun

SNMS Depth Profile of Hard Disk Platter

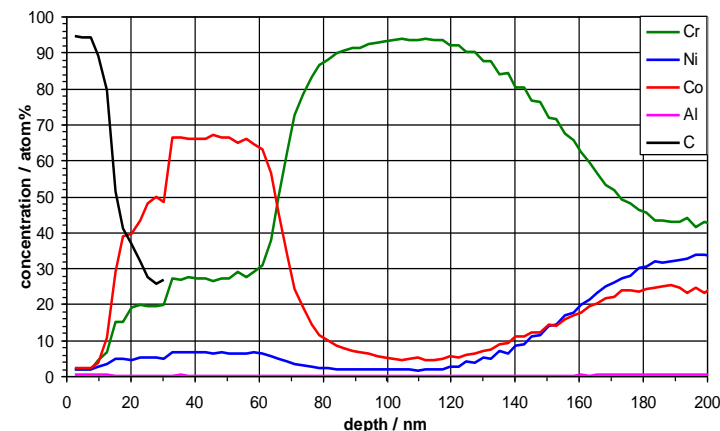
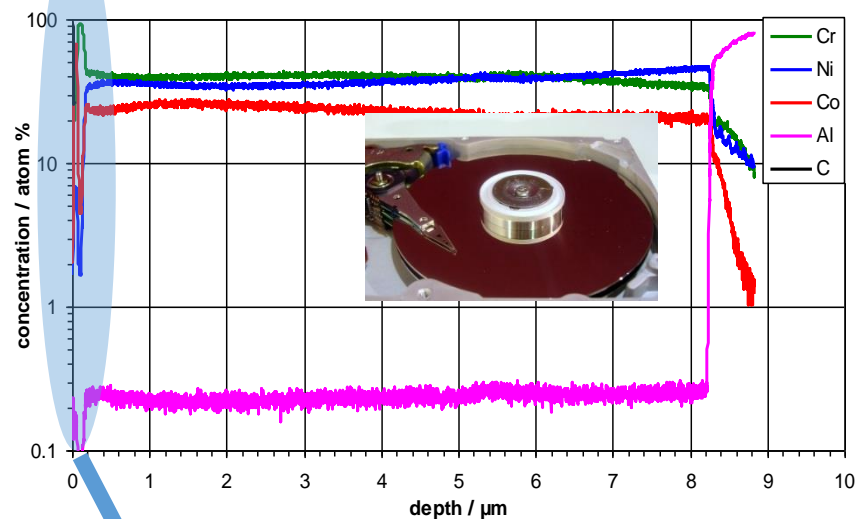

Control of surface topography during sputtering – Oxygen jet

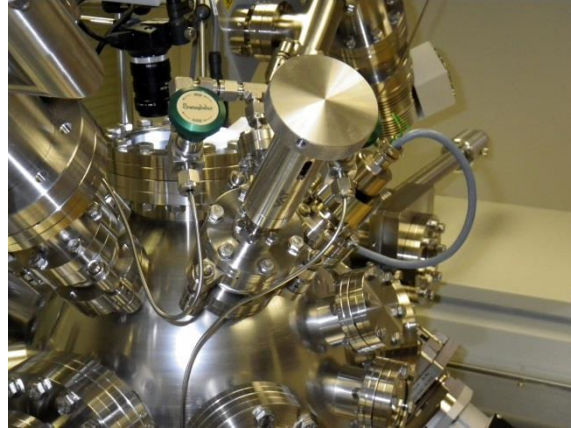
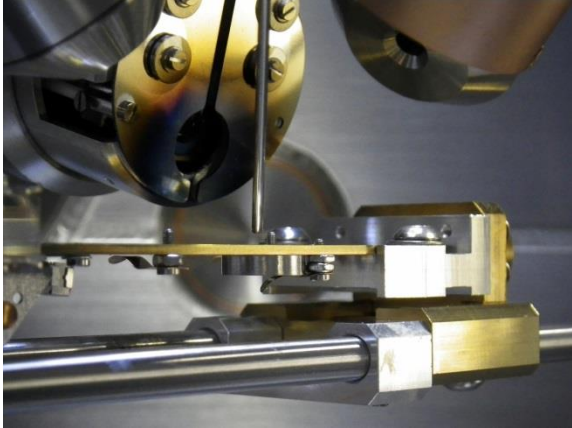

Low energy beams give improved depth resolution but can also induce surface topography.

Fully oxidising the surface using the jet maintains a planar surface and preserves depth resolution.

The jet provides a locally high pressure of pure oxygen over the sample.

2keV 100nA ion beams at 45°. Target 3.6nm Si/Fe multilayer

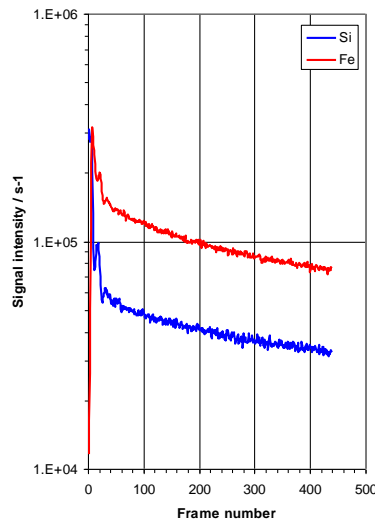

Ar no jet

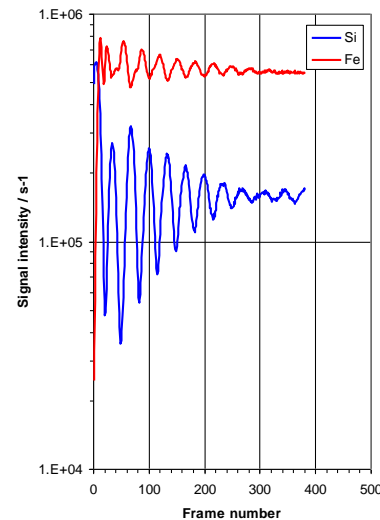

Ar with jet

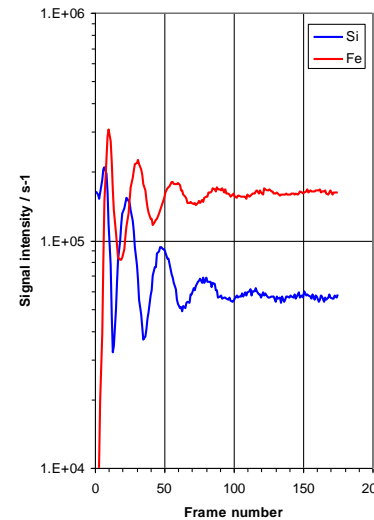

O₂ no jet

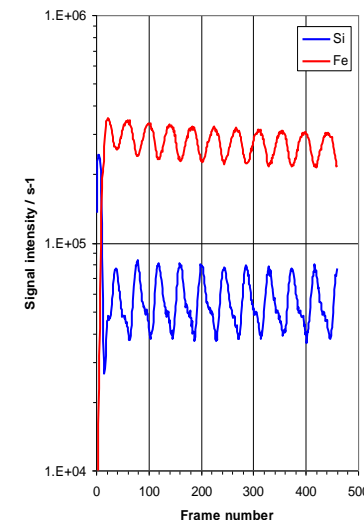

O₂ with jet

Static SIMS – Contamination on Diesel Injector

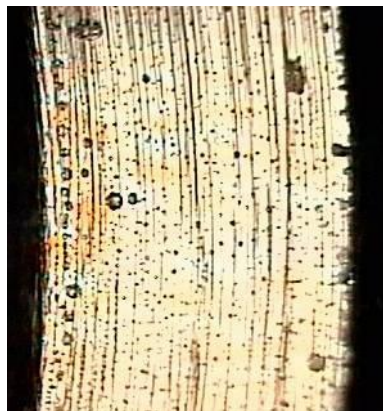

After a period of intense engine running, a hard, stain like, deposit was observed on a fuel injector component.

EDX (energy dispersive X-ray) analysis in the SEM was inconclusive as the thin nature of the deposit meant that most of the excited volume was in the underlying metal.

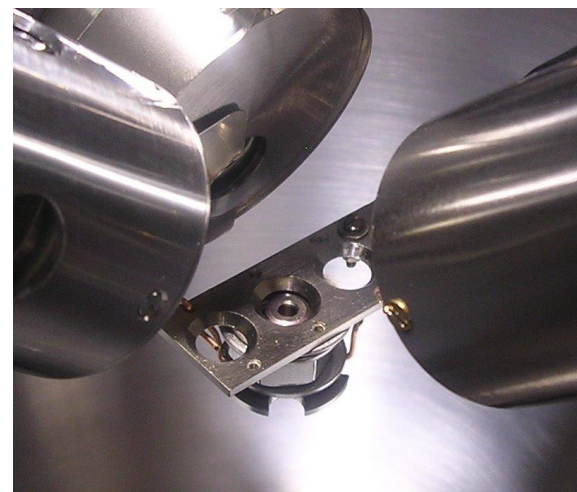
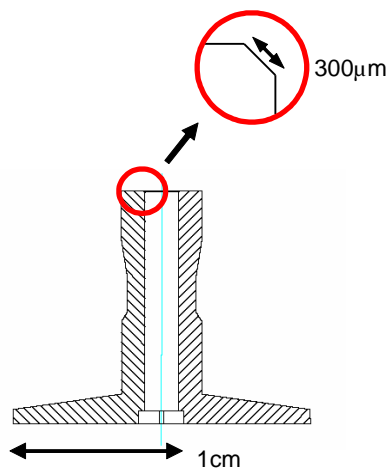

Static SIMS – Contamination on Diesel Injector

^{56}Fe SIMS images of the defective region. The right hand image shows detail in the position of the arrow, where something is blocking the iron signal from the steel. The very bright region is caused by ions being directed into the spectrometer by the angled face.

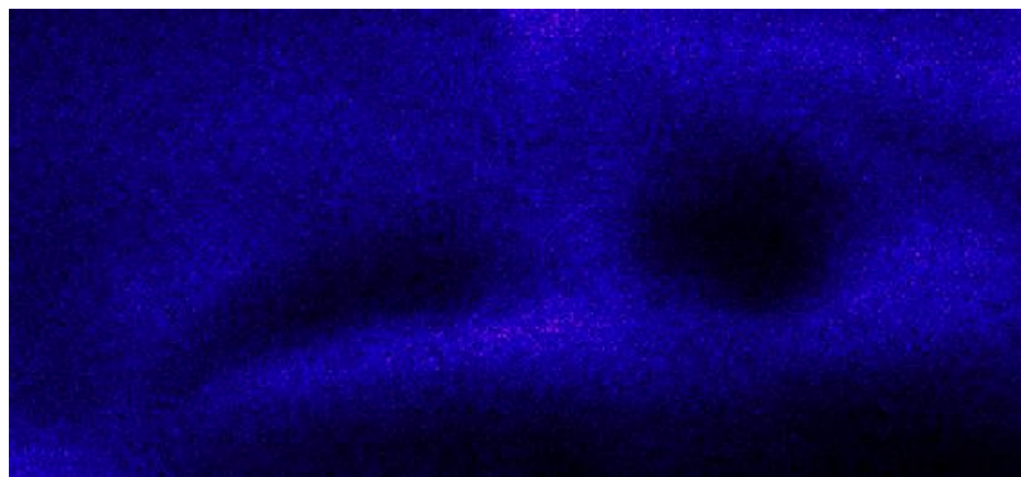
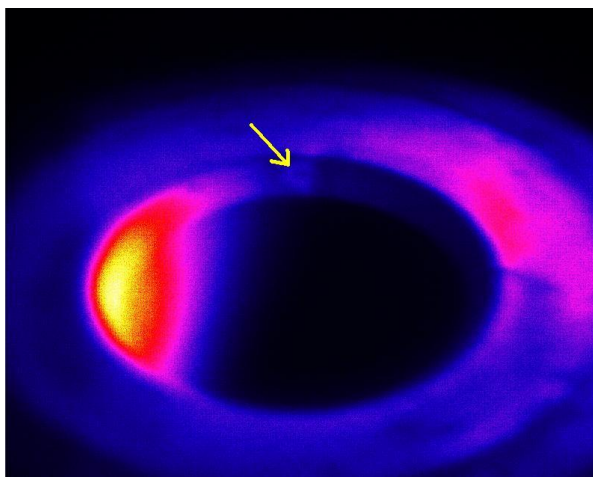

Static SIMS – Contamination on Diesel Injector

Positive SIMS Mass Spectrum of Cleaned Surface

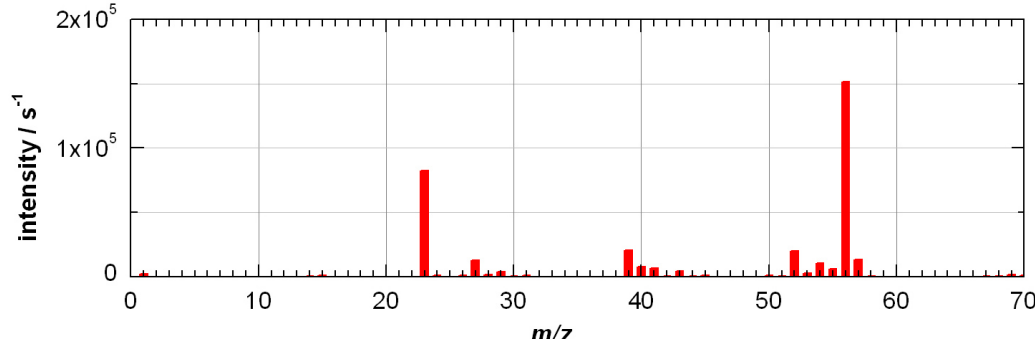

A localised mass spectrum from the steel shows typical constituents,

- Fe at 54-58, with the major isotope at 56
- Cr at 50-54 with the major isotope at 52
- and Na (23) and K(39 and 41) being contaminants to which SIMS is extremely sensitive.

Positive SIMS Mass Spectrum of Contamination

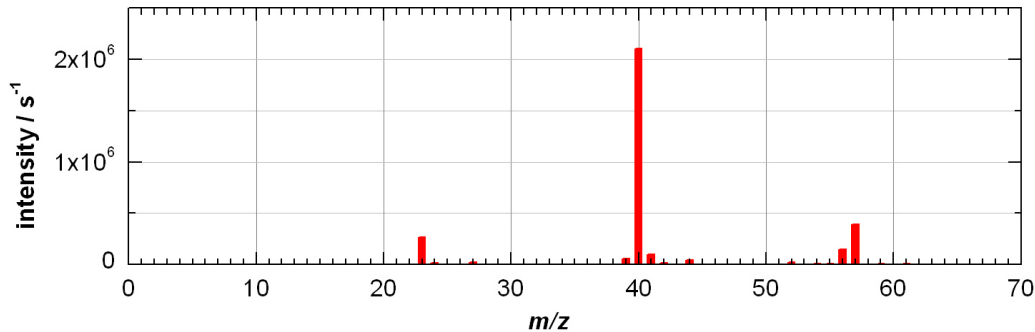

The localised mass spectrum from the defect is dominated by Ca.

The defect is Ca based and it is suggested that this is due to a bio-diesel catalytic production step. This known possible fuel contaminant is limited by EU regulations to 5mg/kg (summed with the Mg content).

New Hiden SIMS Software suite

Philosophy

- Collect all data as images in order to optimise the efficient use of sample material and time by allowing gating and inspection after collection.
- Aim to make it simple, reliable and safe for the inexperienced operator to obtain depth profiles whilst retaining the flexibility that enables expert user develop new protocols and have full control over every aspect of the instrument.



Control of the overall experiment and connection to the mass spectrometer

Periodic Table Species Selection

Periodic Table Species Selection

Available Isotopes	Exact Mass	Abundance
28Si	27.98	92.23
29Si	28.98	4.67
30Si	29.97	3.10

Atomic Mass	Chosen Species	Exact Mass	Abundance (%)
30	Si	29.97	3.10

Set Charge z = 1

Buttons: Inference Calculator, Save to Custom List, Custom List Editor, Cancel, Done

Mass for analysis is chosen from a periodic table and can include molecules and multiply charged species. Experienced users can also input data directly.

Inference Calculator

The interference calculator generates a mathematically produced list from up to 5 elements to assist the user in species selection.

The appearance of a species in the list does not suggest that it will be actually observed.

- Unique, Single Charged Species
- Unique, Double Charged Species
- Interfered Single Charged Species
- Interfered, Double Charged Species

7: Nitrogen

Isotope	Exact Mass	Abundance
47O ₃ Si	46.98	0.01
48O ₃ Si	47.97	0.01
51O ₄	50.99	0.00
57SiSi	56.96	4.31
58SiSi	57.95	2.86
59SiSi	58.95	0.14
62O ₂ Si	61.97	0.18
63O ₂ Si	62.98	0.00
73O ₃ Si	72.95	4.30
74O ₃ Si	73.96	0.00
75As	74.92	100.00
75O ₂ Si	74.94	0.14
75O ₃ Si	74.96	0.01
76O ₂ Si	75.95	0.00
77O ₂ Si	76.95	0.00
79O ₂ O ₂ Si	78.97	0.00
87SiSiSi	86.93	0.13
91O ₄ As	90.91	99.76
91O ₃ O ₂ Si	90.95	0.01
92O ₄ As	91.92	0.04
92O ₃ O ₂ Si	91.96	0.00
93O ₄ As	92.92	0.20

Start Mass: 0 Stop Mass: 100 Done

An integral interference calculator identifies possible mass interferences and suggests relative signal intensities

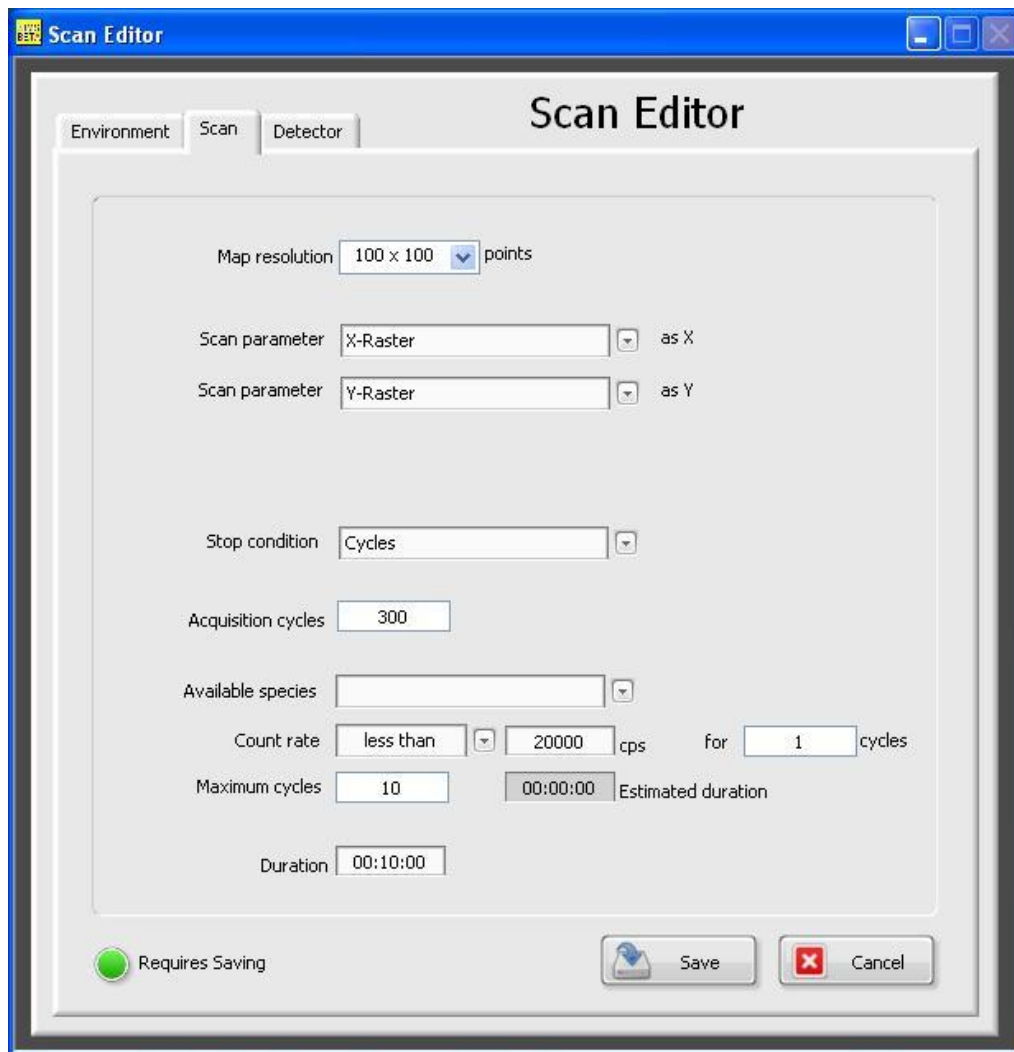

Global Scan Editor

The image resolution is chosen and any stopping criteria set.

The depth profile can be set to terminate automatically when the set criteria is reached - such as an interface, time or signal level.

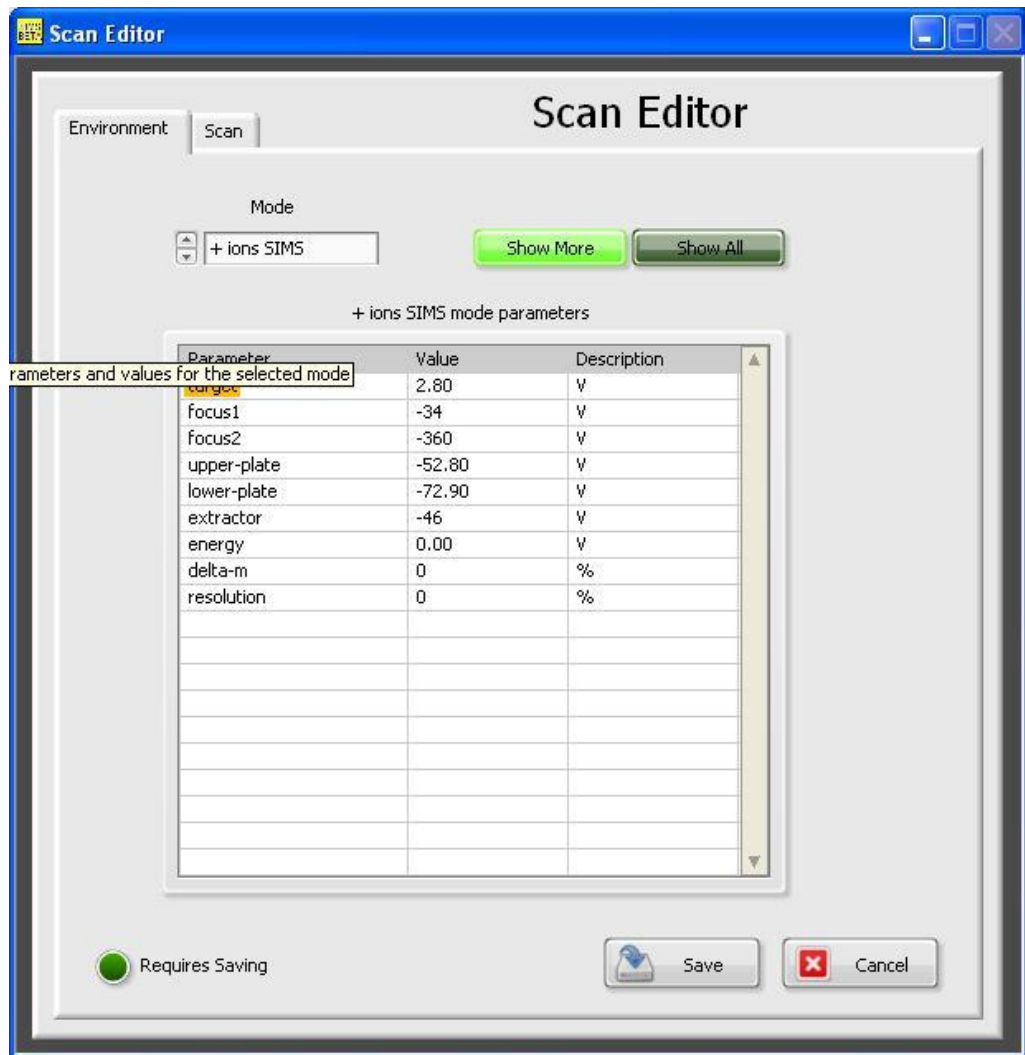

Parameters can be set for each mass, typically a target bias offset is used to differentiate molecular and atomic species.

The parameters list has three levels of access and complexity.



The experiment flow shown here has three channels (Si, Ge and B).

Species can be selected or deselected for analysis – this allows a non-expert user to control a range of experiments from a single template.

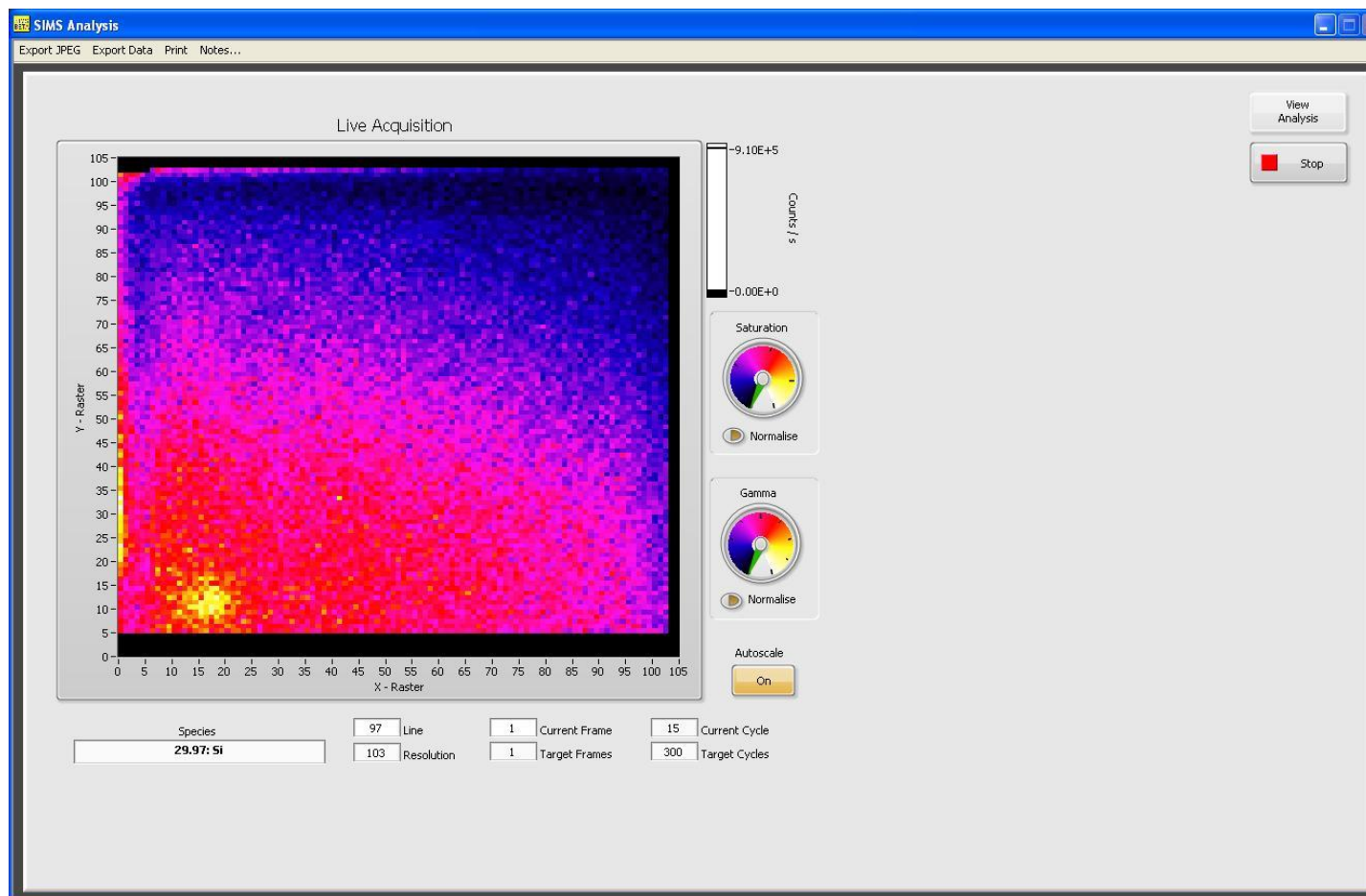

During analysis the live acquisition window displays the signal so that the progress of the experiment can be monitored and surface features observed.

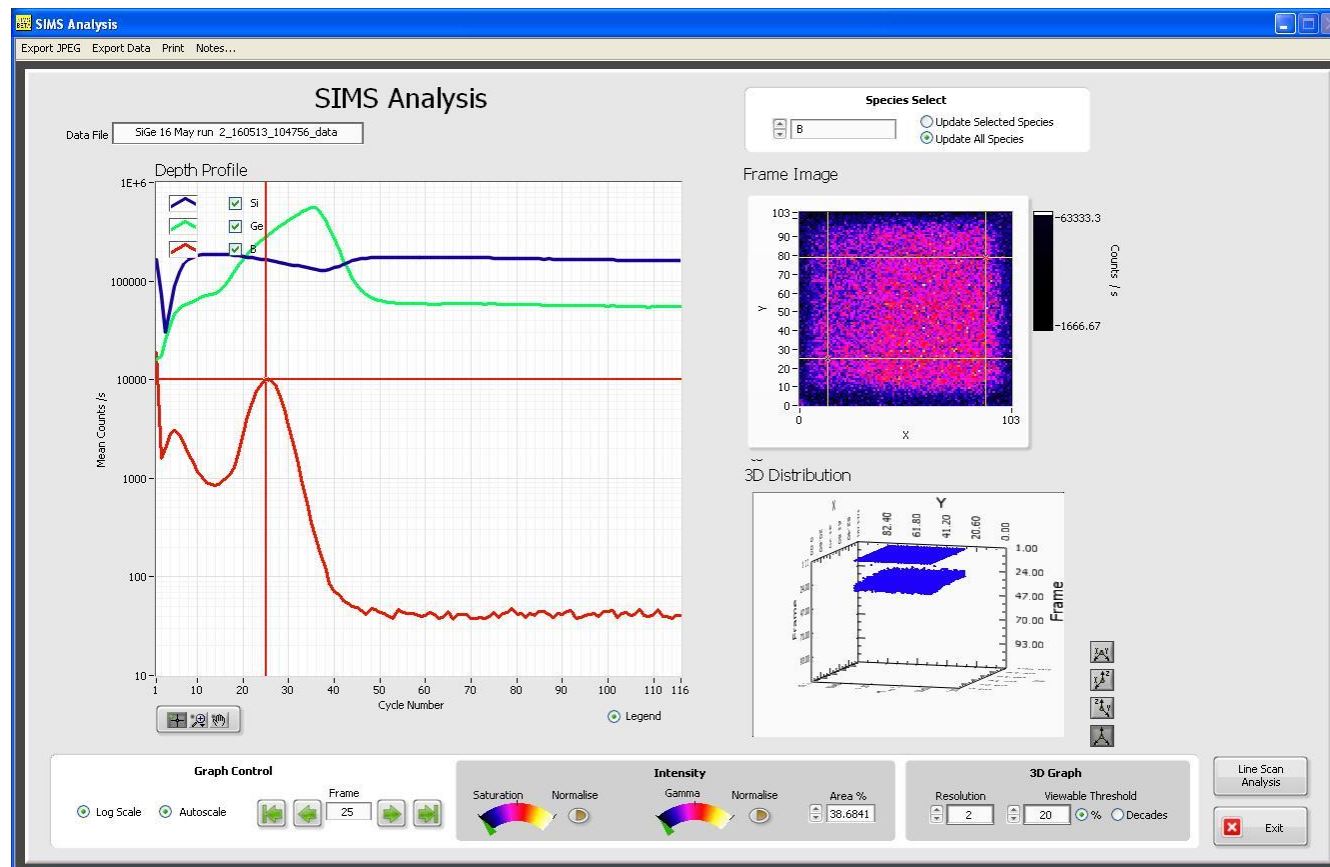

During analysis the analysis window displays the depth profile, image data and a 3D representation of the distribution. It also controls the electronic gating.

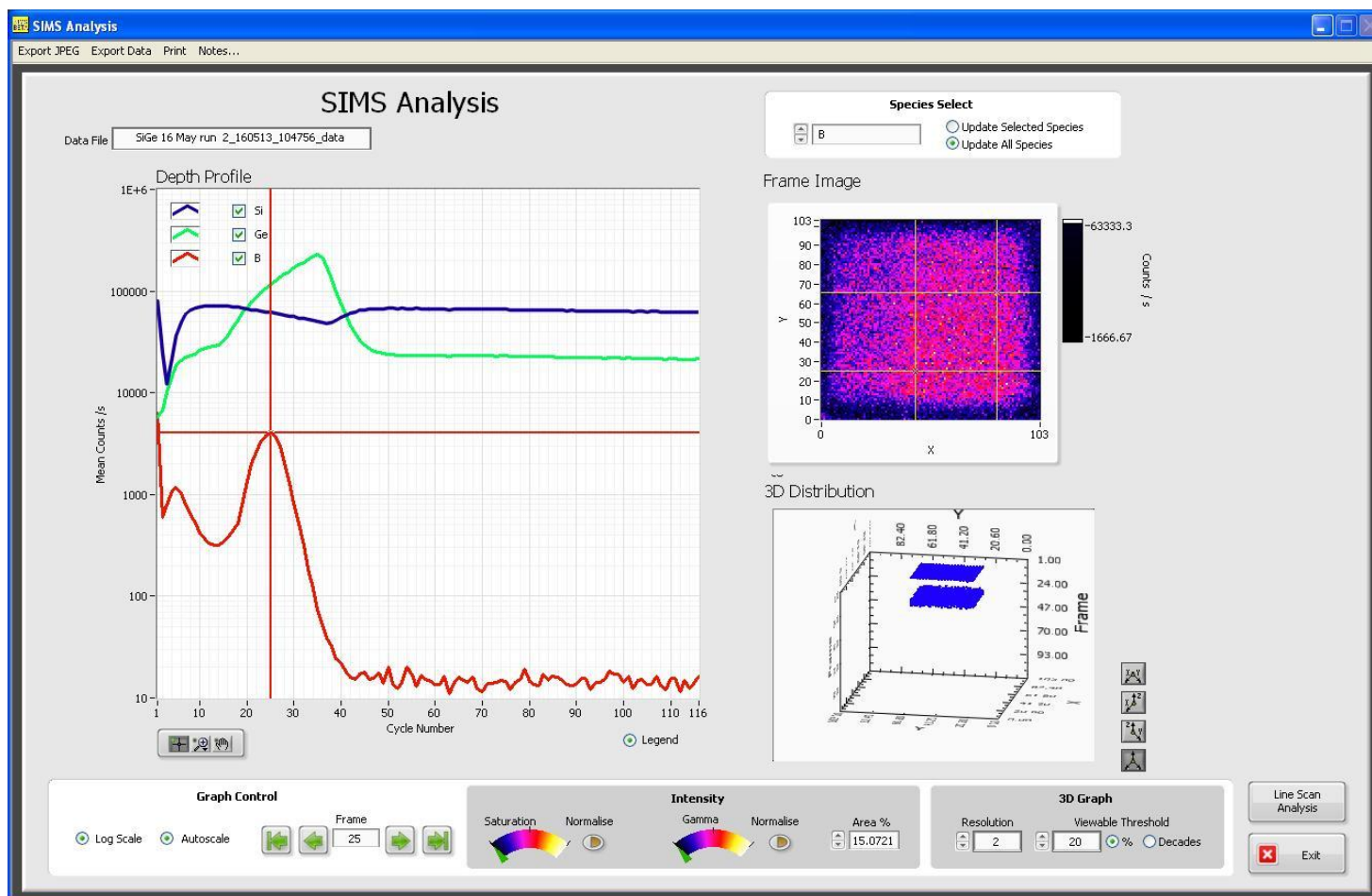

The electronic gate can be optimised independently and interactively for each mass and does not have to be concentric or square.

3D Profiling by SIMS

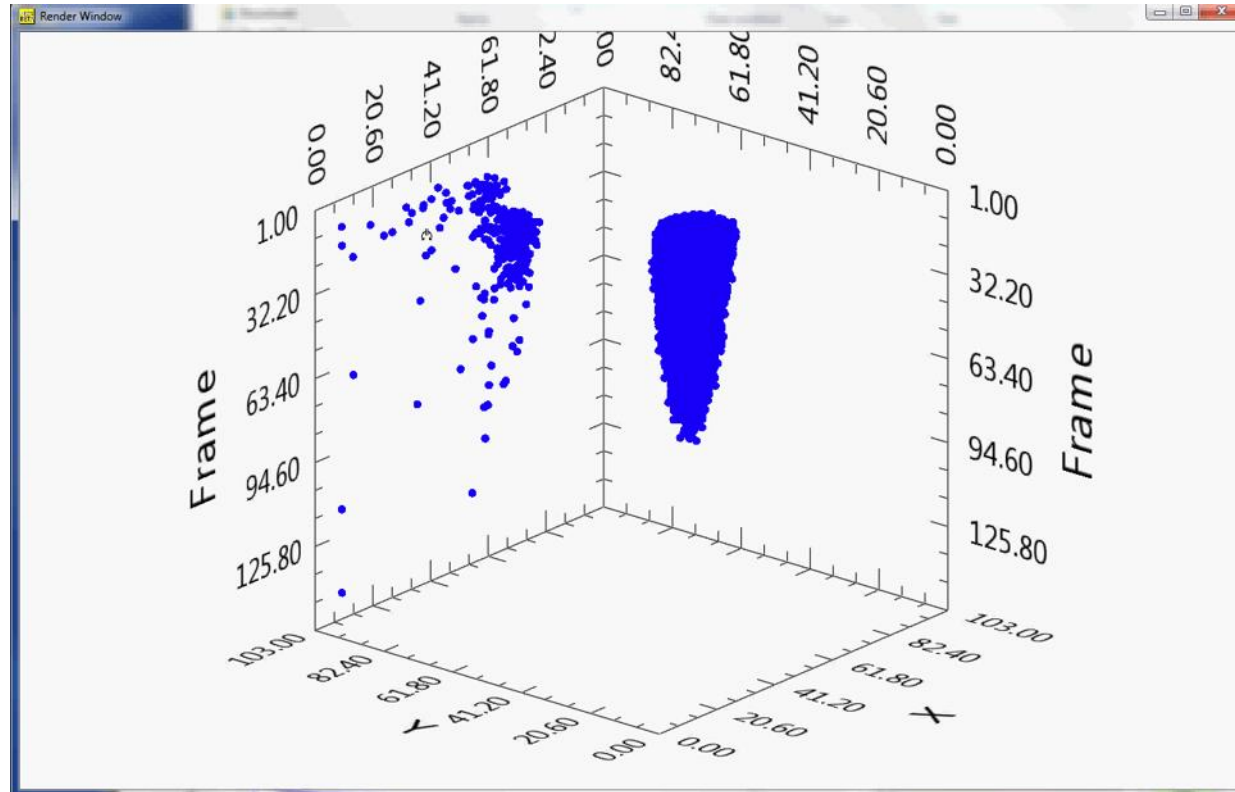

The video shows the mass resolved aluminium signal arising from aluminium oxide grit particles embedded in the work-piece after a grinding operation. Volume is 800 μ m square x 35 μ m deep.

Case Study – Glass Coating (low-e glass)

Low emissivity glass is installed in buildings to increase energy efficiency. In cold weather it reflects heat back into the building – reducing heating costs; in hot weather it reflects heat from the external environment reducing heat build-up within and lessening required air conditioning capacity.

This is achieved, primarily, through the inclusion of a sputter deposited (typically 10nm thick) metallic silver layer within a sandwich of protective oxides.

Surrounding layers may be chosen to impart a particular colour to the glass but ideally white light should pass through so that colours are rendered correctly within the building.

Case Study - Glass Coating (low-e glass)

Low Emissivity Architectural Glass

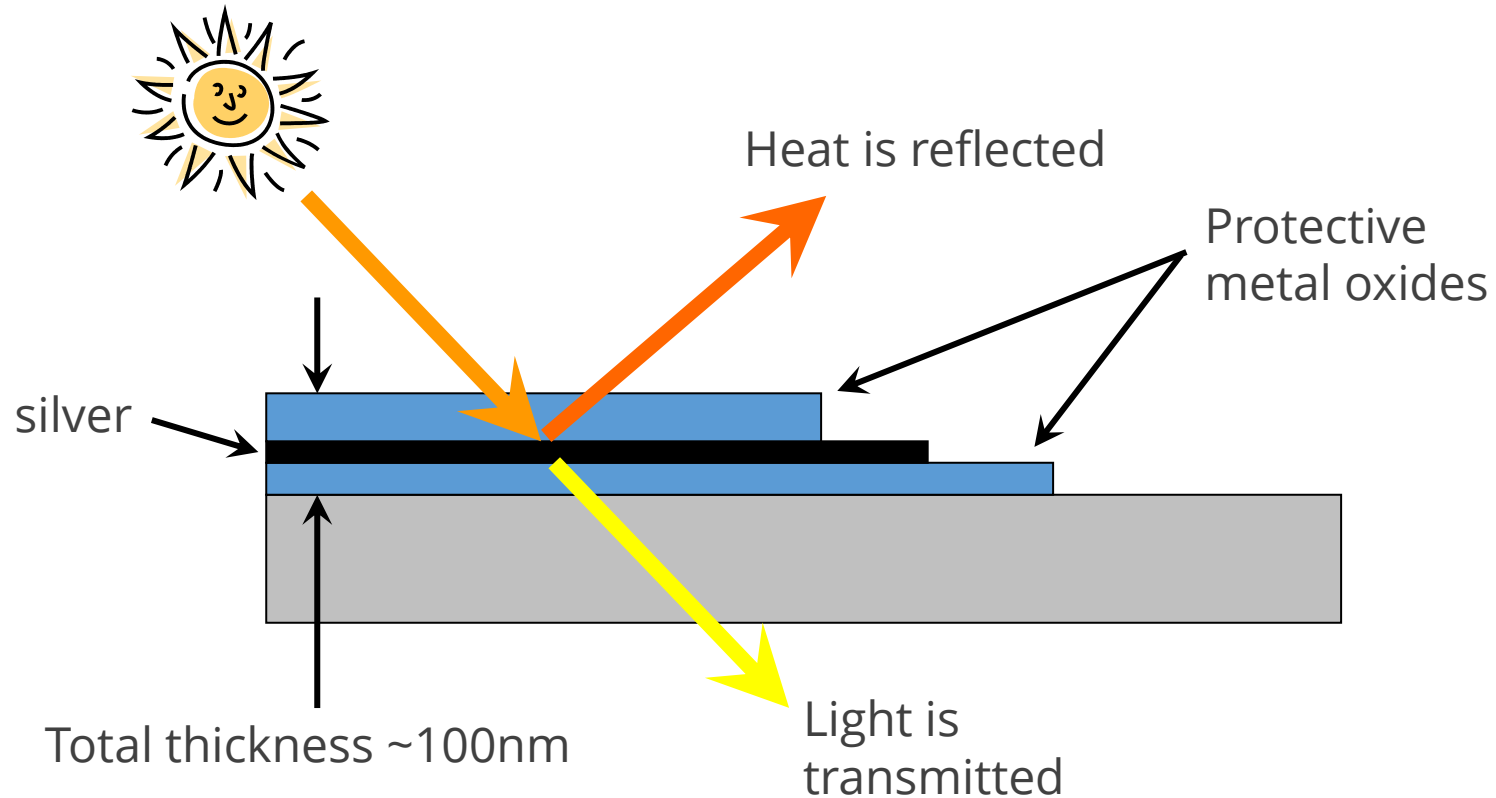

Case Study – Glass Coating (low-e glass)

SIMS can provide analysis of glass layers for:

- Failure analysis, identification of defects, impurities and contamination
- Characterisation of processes
- Reverse engineering

Case Study - Glass Coating (low-e glass)



The diagram shows a typical low-e stack where the active silver layer is protected by a mixture of metal oxide layers.

Case Study - Glass Coating (low-e glass)

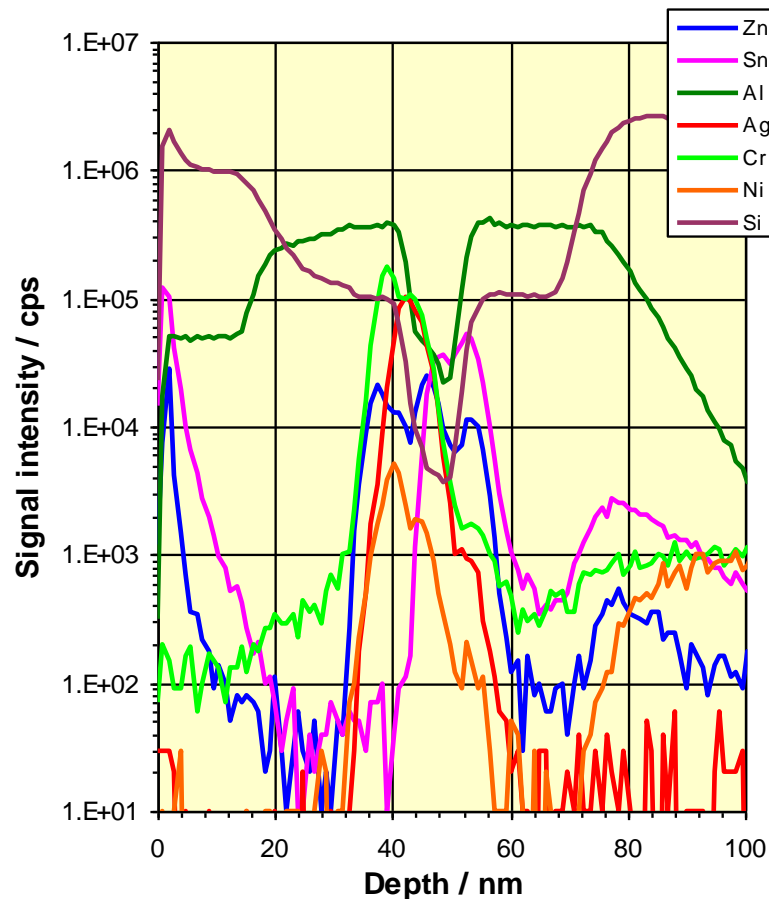

The SIMS depth profile was collected using 5keV Ar ions focused to an 80µm spot and rastered over an area of 400 x 550µm. Positive secondary ions were collected and a 500eV electron flood was employed to prevent surface charging.

Case Study - Glass Coating (low-e glass)

Beginning at the exposed surface, the first layer is extremely thin and is partly consumed by the pre-equilibrium region at the start of the analysis. However, zinc and tin signals are clearly present at the very surface. There is a high silicon signal (rising to a level almost of that in the glass substrate) suggesting that a thin SiO₂ layer may exist in the vicinity of the ZnSnOx.

The silicon nitride layer is characterised by a uniform concentration of silicon, however, this layer also contains aluminium, estimated to be ~7% (atomic).

Beneath the SiN layer lies a similar thickness of AlN. Interestingly, throughout this layer the Cr signal is rising, albeit from three orders of magnitude below the eventual peak. SIMS is perfectly suited to the investigation of this type of low concentration feature and for the analysis presented here it was necessary to significantly reduce the sensitivity to ensure that the peak of the Cr signal did not saturate the detector.

The region below the AlN contains the thin silver layer and its associated thin protective barrier layers containing Zn, Al, O Ni and Cr. The design thickness of the NiCrOx layer is only 1 nm and there has been some mixing of this into the silver layer during analysis.

Immediately below the silver, the thin Zn and ZnSnO layers are visible, before the final AlN layer and the glass substrate.

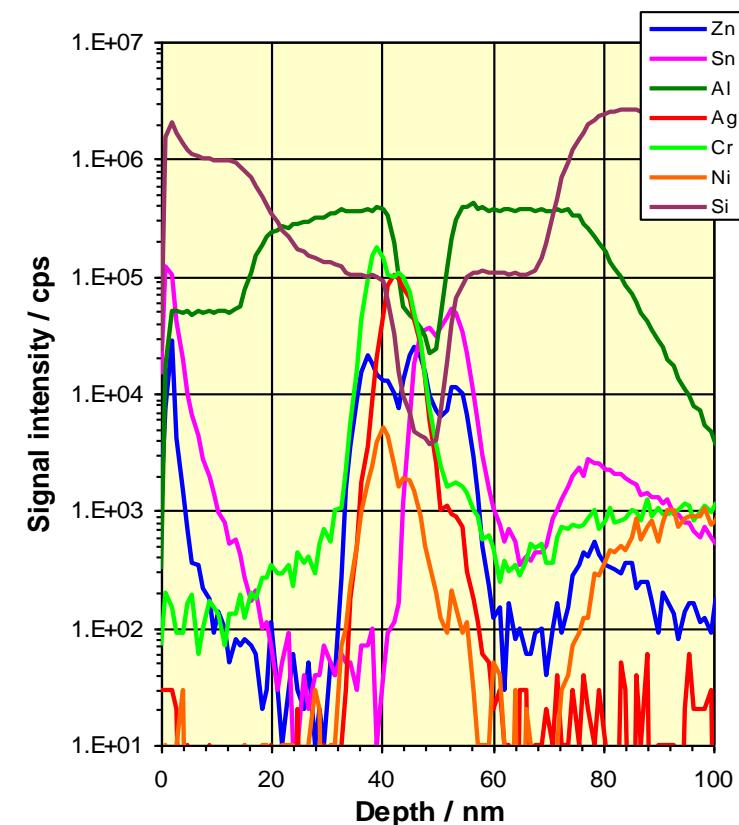

Case Study – Glass Coating (low-e glass)

Such a profile is very complex to quantify, however, by comparing similar profiles from different parts of the glass pane it is possible to investigate abnormalities.

Here the silver and oxygen signals from left and right hand sides are overlaid, showing no difference.

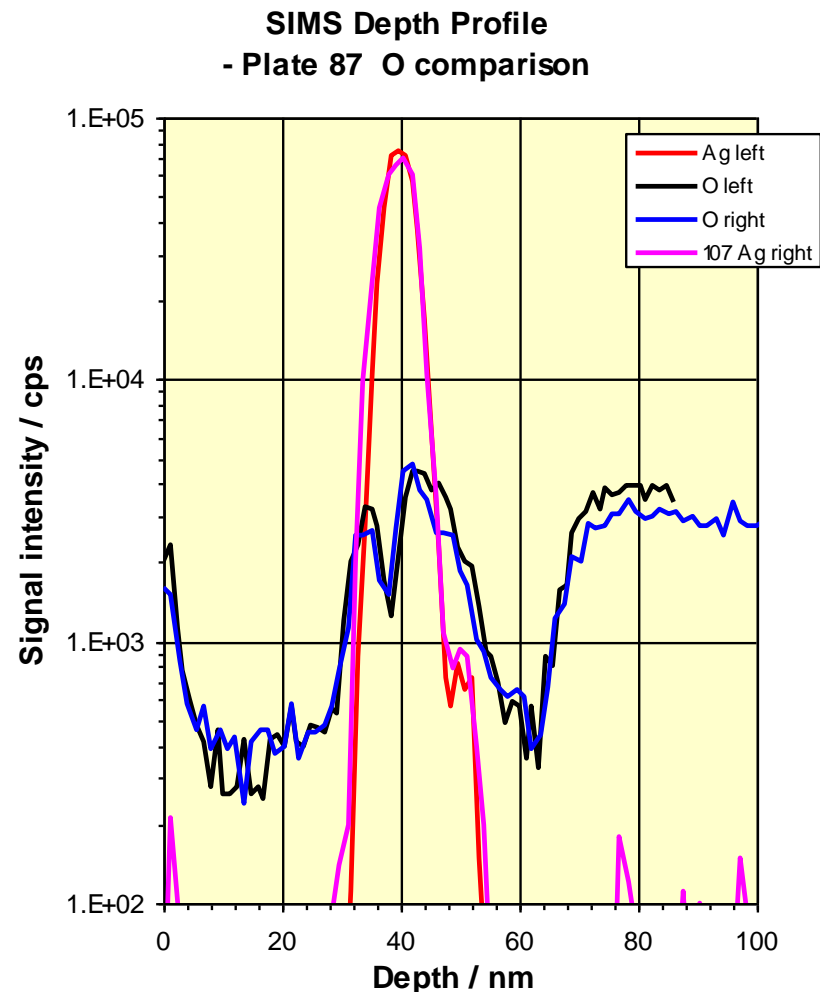

Case Study - Glass Coating (low-e glass)

When the Cr signals from the left (L), middle (M) and right (R) hand sides are overlaid it becomes immediately apparent that the right hand edge is deficient in Cr.

It should be noted that the NiCr layer is expected to be only about 1 nm thick and so this represents a very sensitive analysis.

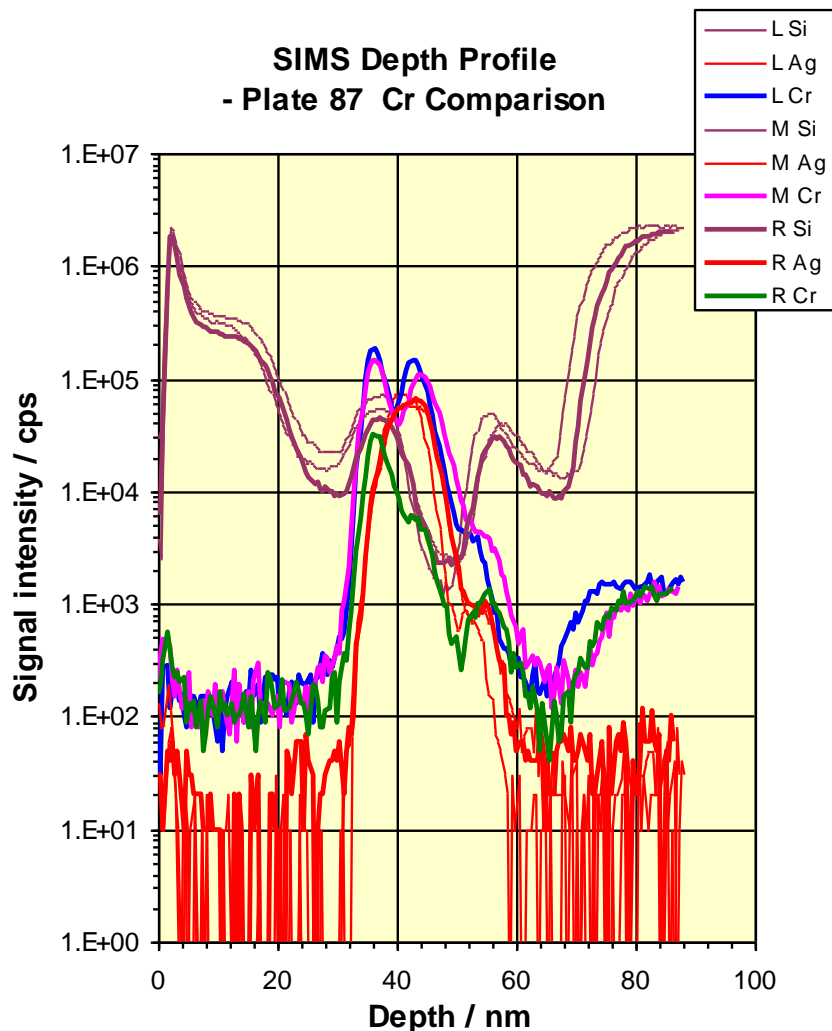



- www.HidenAnalytical.com
- The Hiden website is an excellent resource with product pages, brochures, catalogues, product pages with some application notes, presentation and other information.
- Contact +44 1925 445225 for direct support.