

HideN HPR-20 R&D

for Advanced Research



Introduction

The Hiden HPR-20 R&D is configured for continuous analysis of **gases and vapours** at pressures near **atmosphere**.

Operating to 200°C, the QIC (quartz inert capillary) flexible 2 m capillary inlet provides fast response times of less than 300 ms.

The HPR-20 R&D system has a mass range of 200 amu (300, 510, 1000 amu options) and a detection capability from **100% to less than 5 ppb**.

HPR-20 R&D Vacuum Schematic

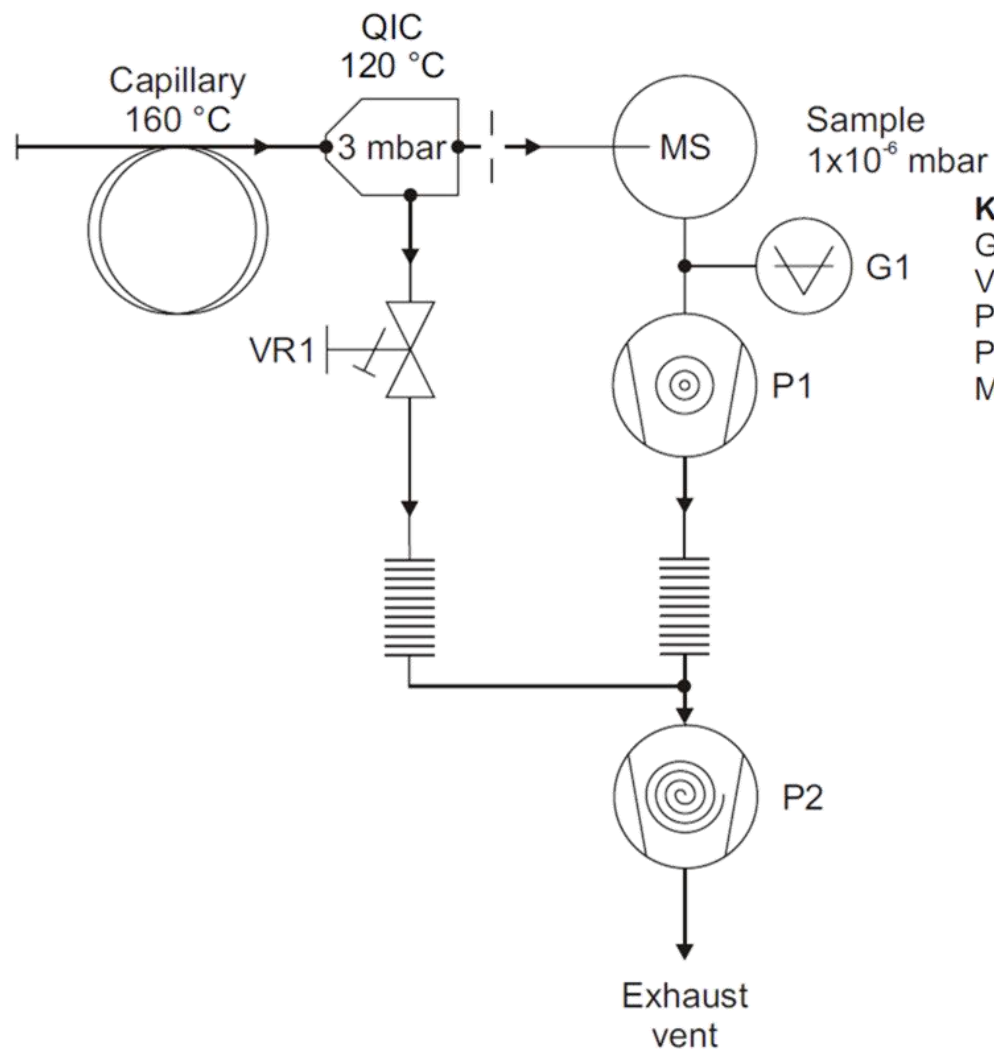
**Key**

- G1 Penning gauge
- VR1 QIC Inlet bypass control valve
- P1 60 l/s turbo drag pump
- P2 Backing and bypass Scroll pump
- MS UHV Housing (Mass spectrometer chamber)



*Backing and bypass
Scroll Pump*

HPR-20 R&D Analyser: Hiden HAL 3F Series Triple Filter Mass Spectrometer

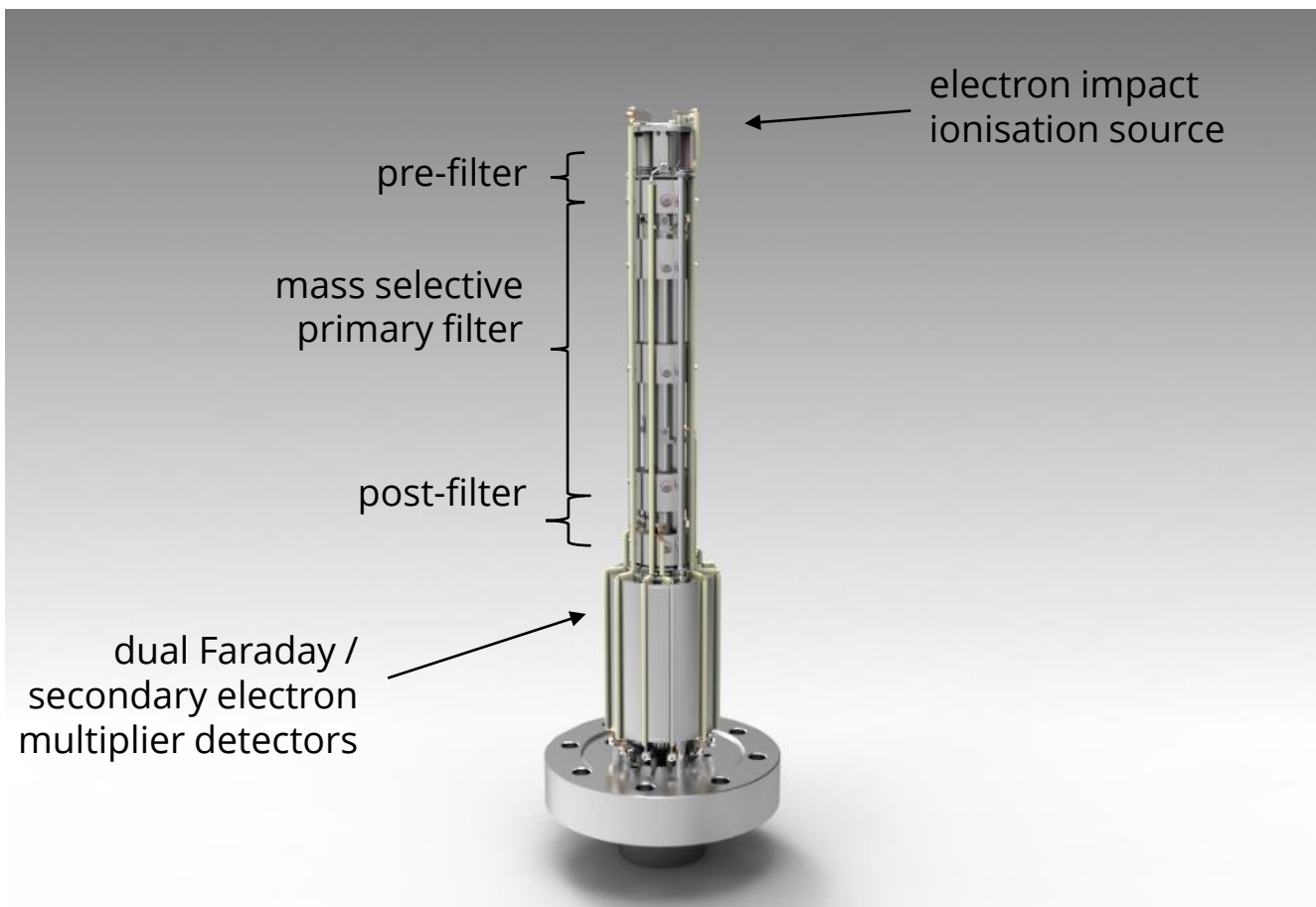

Triple Filter Mass Spectrometer

Why have a triple filter?

Two main advantages:

1. Strict control over the quadrupole entrance and exit fields provides **enhanced sensitivity for high mass transmission** and **increased abundance sensitivity**
2. **Enhanced long-term stability.** The bulk of the deselected ions from the quadrupole ioniser deposit harmlessly on the RF-only pre-filter stage, minimising contamination on the mass selective primary filter.

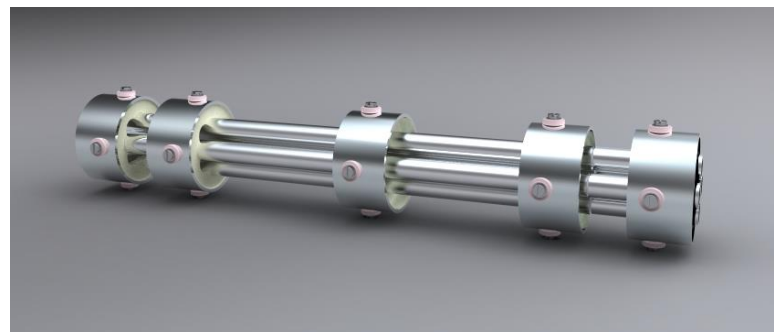

QIC Inlet Technology

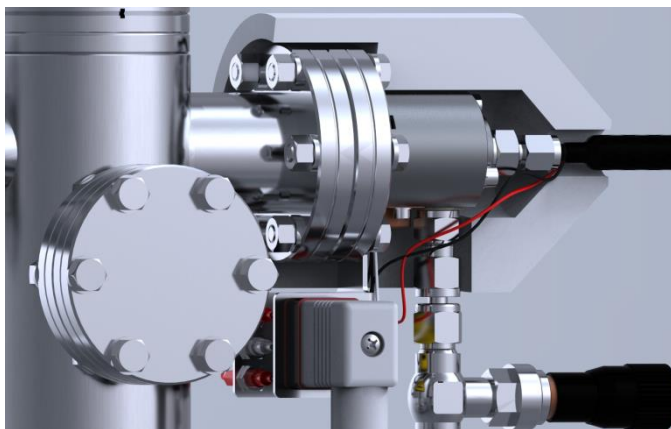

- | | | |
|--------------------------------------|---|--------------------------------|
| Quartz and Platinum Wetted Surfaces | → | No memory effects |
| Heated Capillary | → | No condensation effects |
| Flow Matched | → | Optimum response / recovery |
| Minimal Internal Volume | → | PPB detection |
| Interchangeable Sampling Capillaries | → | Analysis from 10 mbar to 2 Bar |

Fast Response to Permanent Gases / Vapours

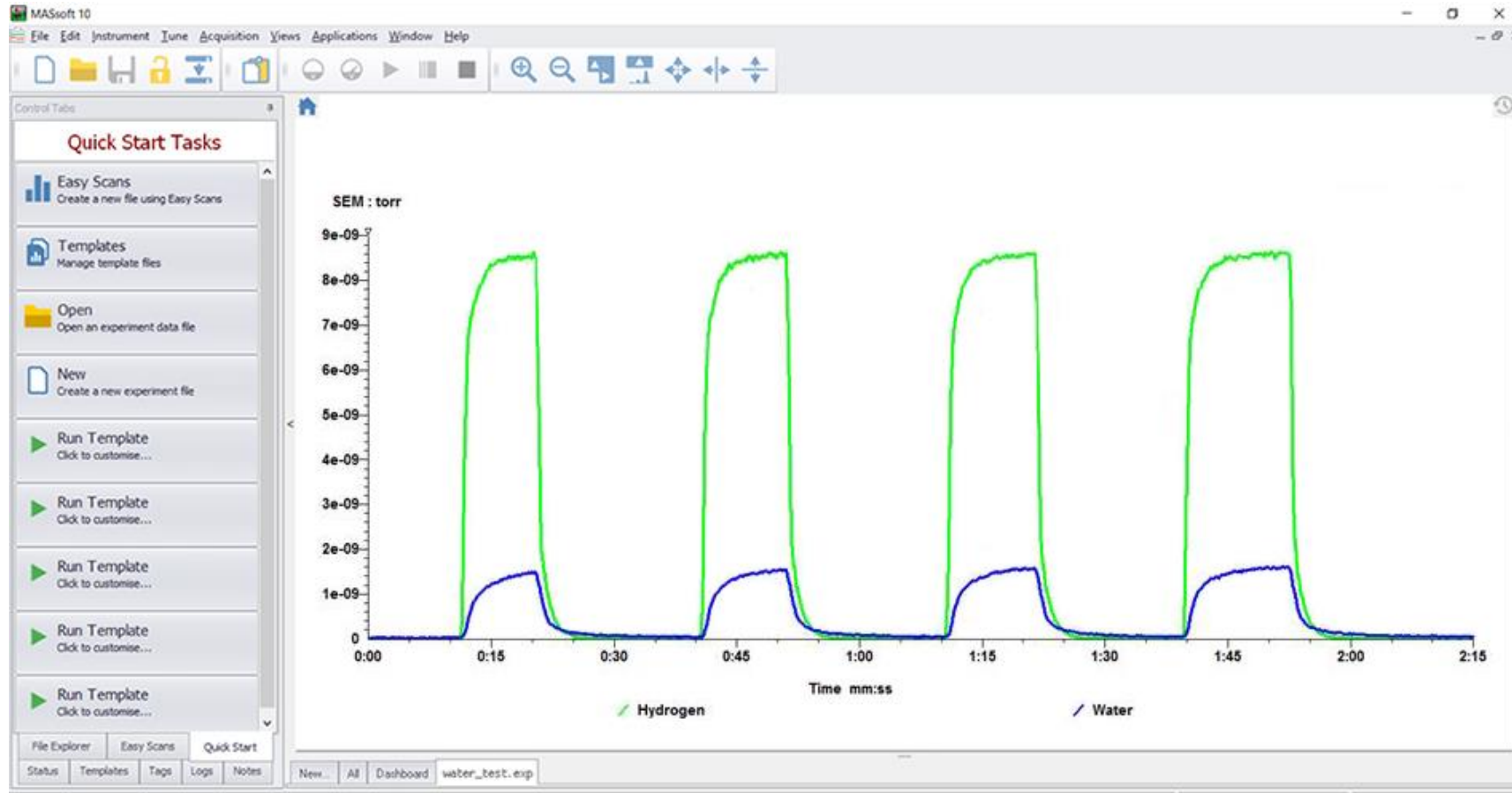

Data shows the response of a HPR-20 system to gas and vapour during switching between a dry He stream and a wet H₂ and Ar flow. For clarity, only the H₂ and H₂O data is shown in the graph.

Typical Mass Spectrum of Air

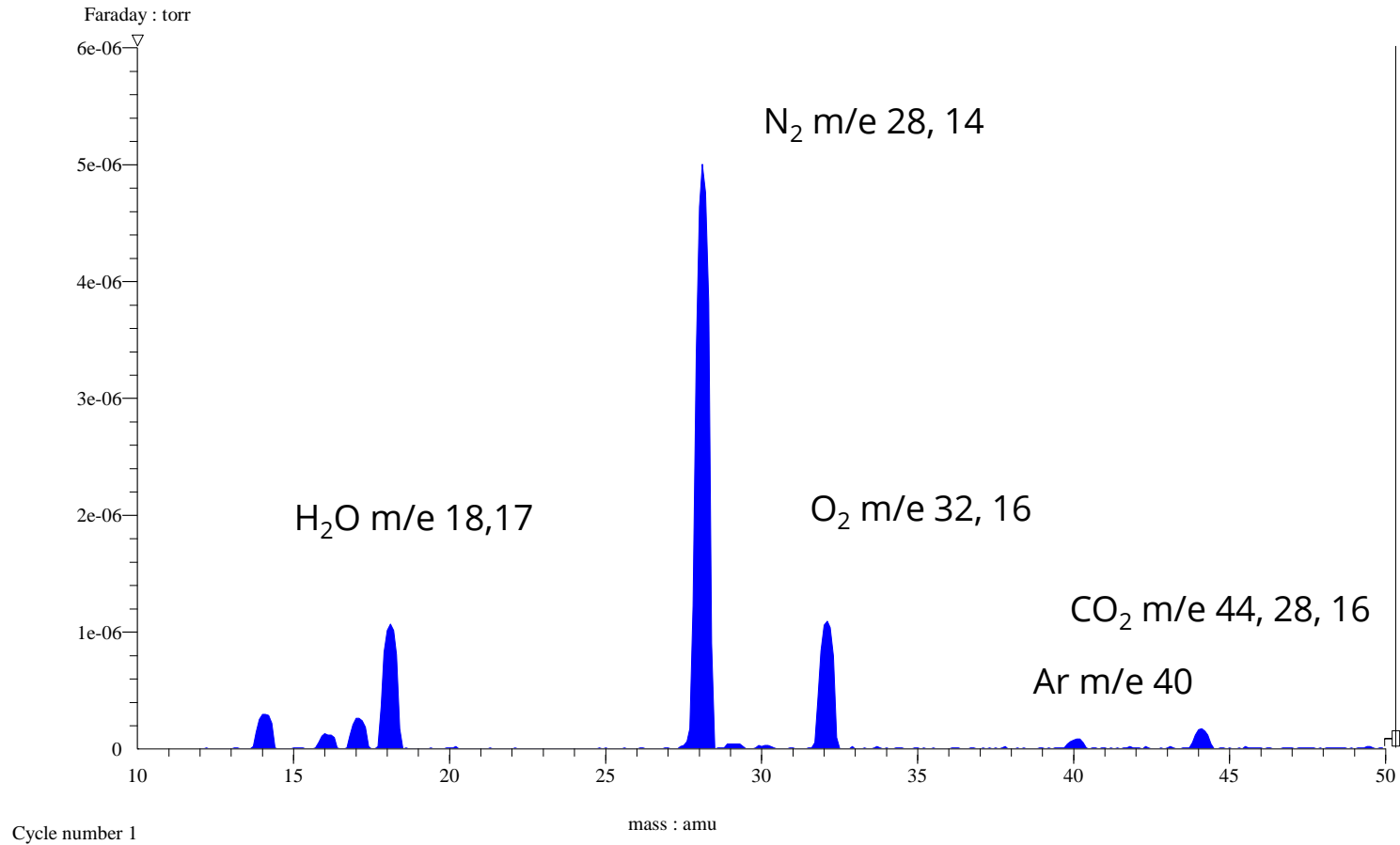

Note: Different species can have the same mass e.g. CO, N₂ m/e 28

Soft Ionisation

Unique to Hiden gas analysis systems, soft ionisation allows users to selectively ionise different gases by setting the ionisation energy for a particular mass.

This powerful technique can simplify the analysis of otherwise complex cracking patterns from multi-component gas/vapour mixtures.

The ionisation energy can be altered from 4 to 150 eV, in 0.1 eV increments. Standard operation is at 70 eV.

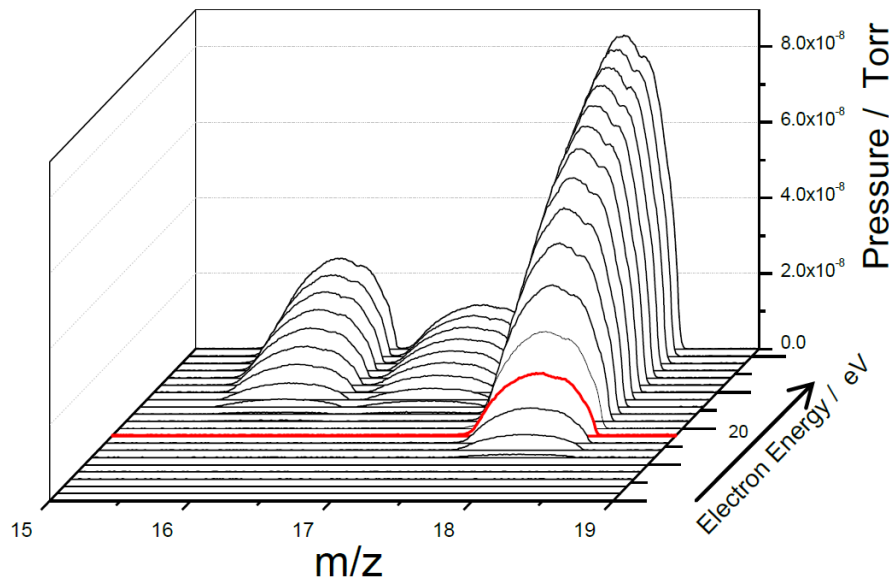

Figure 1 A: m/z vs Electron energy-H₂O/Air

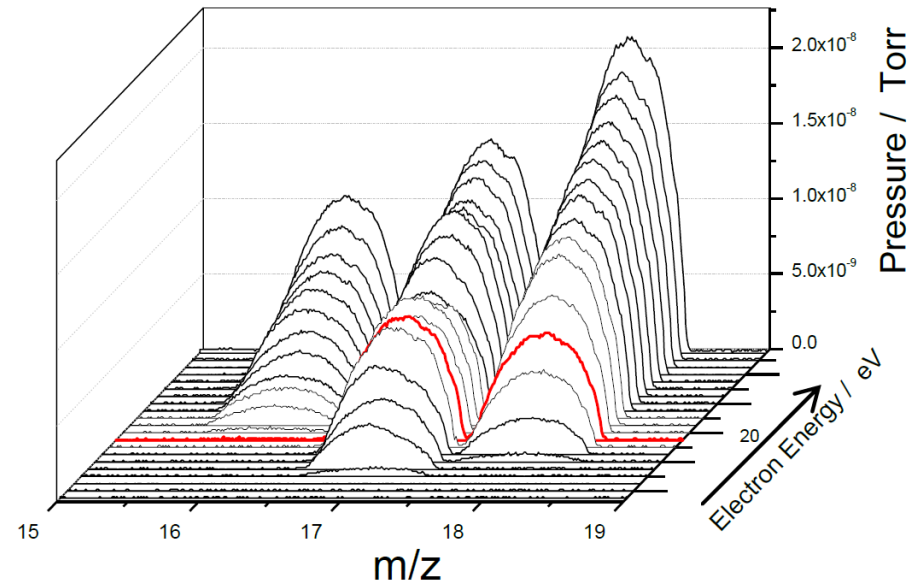
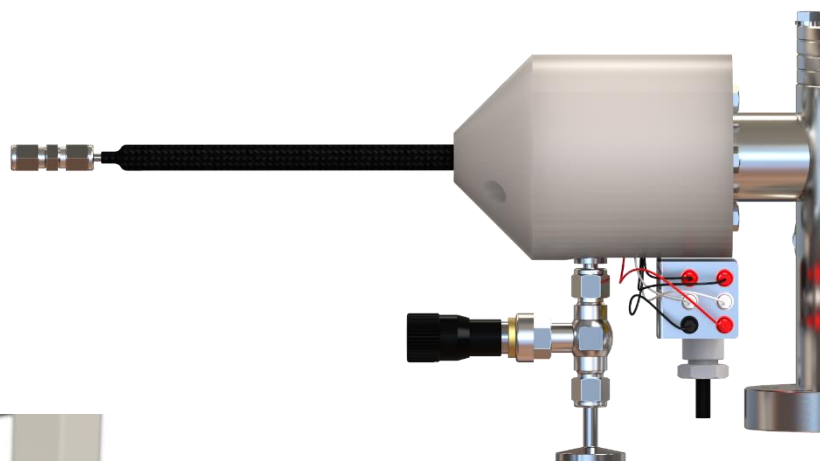
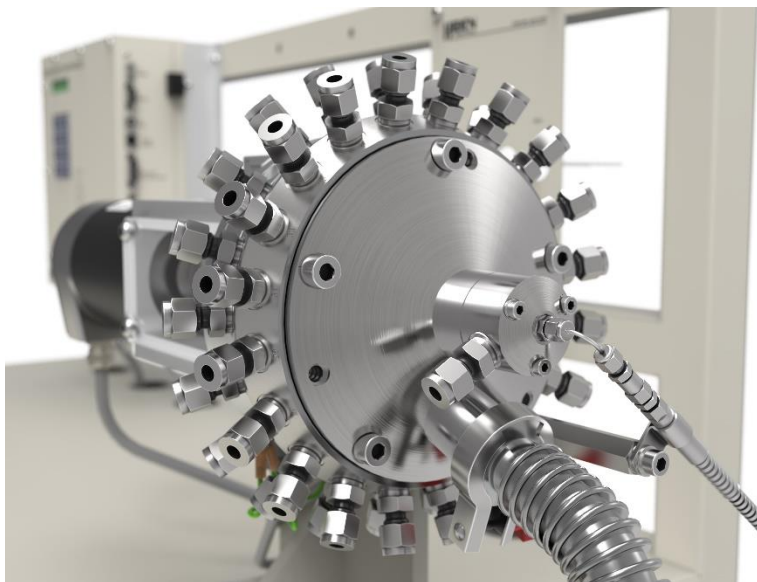

Figure 1 B: m/z vs Electron energy-NH₃/ H₂O/Air mix

Gas Sampling Options

Pressure:

Inlet options are available for sampling both above and below atmospheric pressure. High pressure inlets for sampling at **up to 30 bar** and special capillaries for sampling **down to 1 mbar**.



Multi-stream selectors:

2, 8, 16, 20, 40 and 80 way options

Temperature:

- Heated capillary extensions
- High temperature capillary inlets
- Hot-zone adaptors
- Heated multi-stream inlets

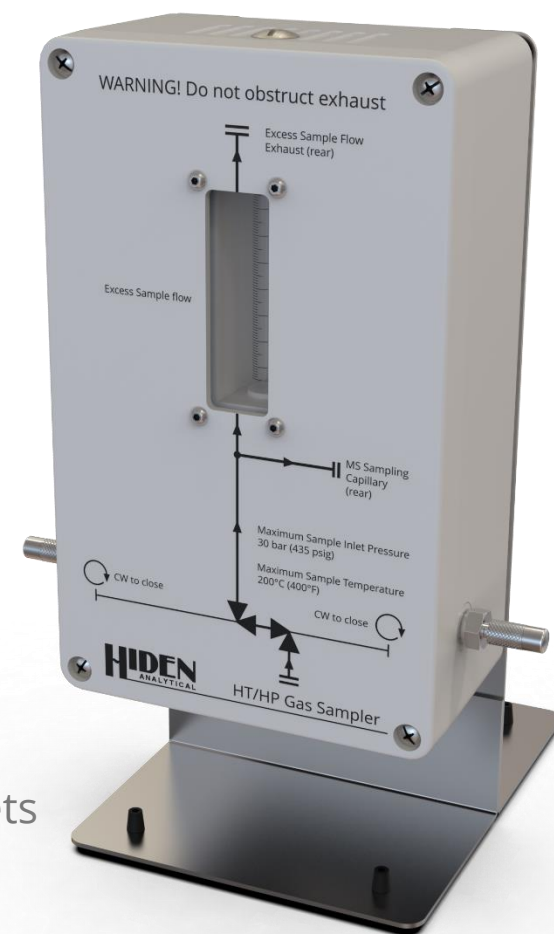

MASsoft Professional Control Software

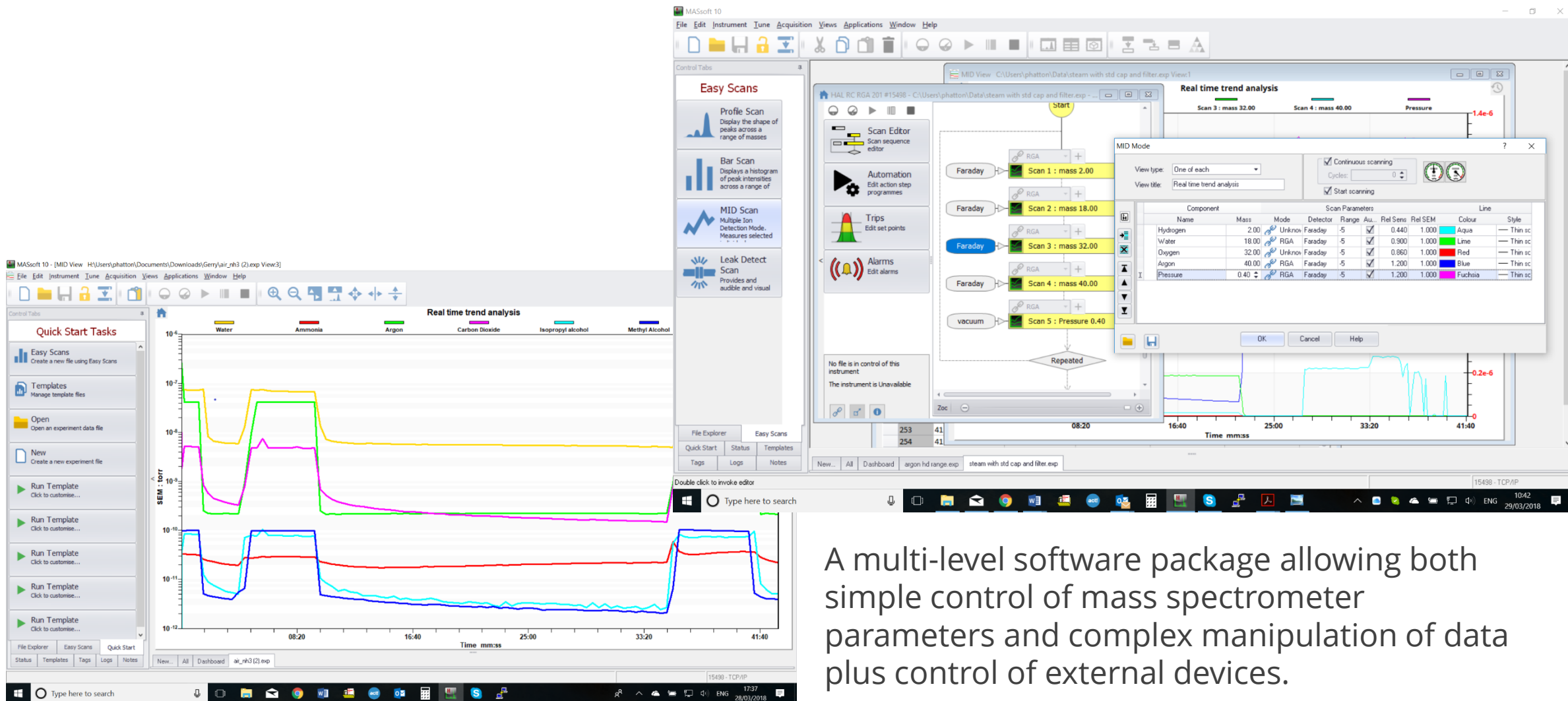

A multi-level software package allowing both simple control of mass spectrometer parameters and complex manipulation of data plus control of external devices.

QGA 2 Software for Quantitative Gas Analysis

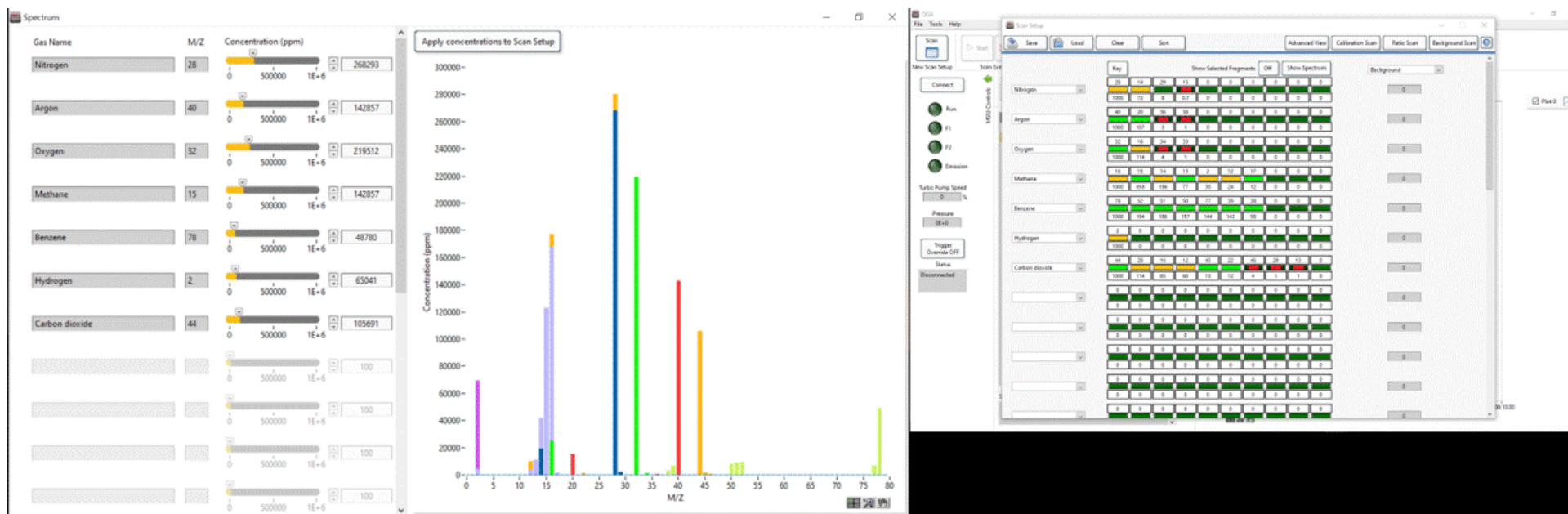

An application specific software package for quantitative gas and vapour analysis providing real time continuous analysis of up to 32 species with concentrations measured in the range 5PPB to 100%

- Automatic subtraction of spectral overlaps
- Automated calibration routines
- Mass spectral library with intelligent scan feature
- Multi-stream support

Applications

- Catalysis
- Reaction Kinetics
- TPD/TPR/TPO
- Thermal Analysis Mass Spectrometry
- Gas Purity Analysis
- Process Characterisation
- Fermentation Off Gas Analysis
- Environmental Gas Analysis
- Combustion Studies
- CVD/MOCVD



Applications: Catalysis Research

- Catalyst characterisation
- Kinetic and thermodynamic measurements
- TPD, TPO, TPR, TP-Reaction
- On-line continuous product analysis
- Total Surface Area / Metal Surface Area
- Mechanisms of Surface Reactions
- Heats of Adsorption and Co-adsorption
- Operando Studies

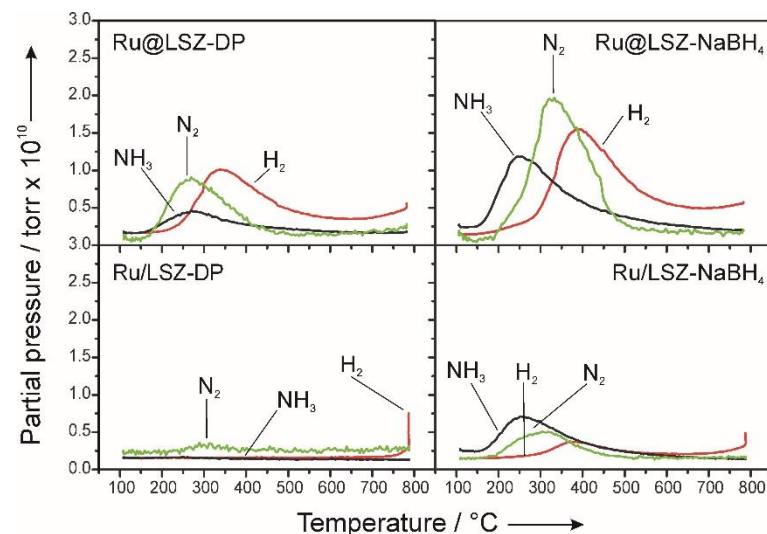

NH₃-TPD on embedded Ru@LSZ and impregnated Ru/LSZ catalysts.

Ref: Lorenzut et al. (2011) *Hydrogen production through alcohol steam reforming on Cu/ZnO-based catalysts*, Applied Catalysis B, **101** (3&4), 397-408.

Applications: Environmental Gas Analysis

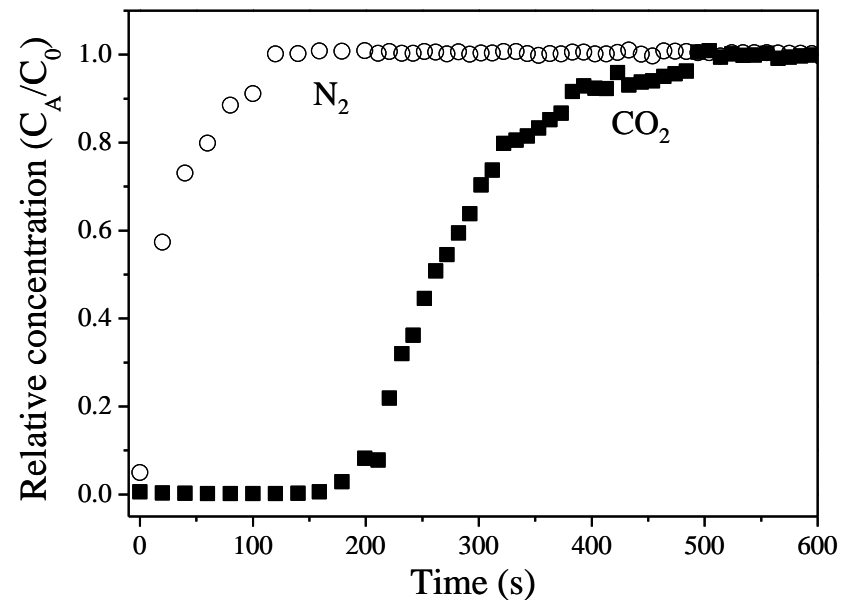
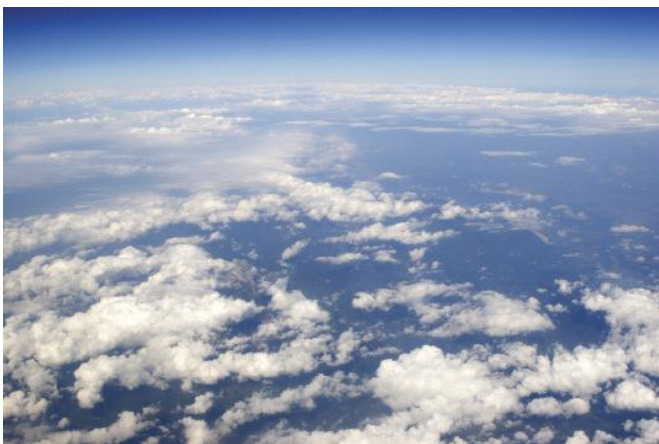

Breakthrough curve of CO₂ (15% CO₂, 85% balance N₂) on mesoporous alumina.

Ref: Yang et al. (2010) CO₂ adsorption over ion-exchanged zeolite beta with alkali and alkaline earth metal ions, *Mesoporous Materials* **135** (1-3), 90-94.



THE UNIVERSITY
OF QUEENSLAND
AUSTRALIA

Hidden HPR-20 Users



Imperial College
London

NASA
Dow Chemical
Exxon-Mobil
Imperial College
MIT



Massachusetts
Institute of
Technology

University of British Columbia
University of Queensland
BASF



جامعة الملك عبد الله
للعلوم والتقنية
King Abdullah University of
Science and Technology

Seoul National University
Suzuki

University of Cambridge
Beijing Institute of Technology

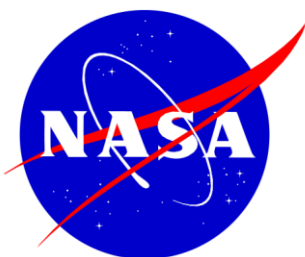

Samsung
ETH Zürich
KAUST



Durham University
Siemens
Shell

SIEMENS



ETH

Eidgenössische Technische Hochschule Zürich
Swiss Federal Institute of Technology Zurich

Summary

- Bench-top triple filter quadrupole mass spectrometer gas analysis system
- Real-time, multi-species analysis – 5 PPB to 100%
- Fast response to permanent gases and vapours – less than 300 ms response time
- Soft ionisation for reduced spectral fragmentation and simplified data interpretation



- 
- www.HidenAnalytical.com
 - The Hiden website is an excellent resource with product pages, brochures, catalogues, product pages with some application notes, presentation and other information.
 - Contact +44 1925 445225 for direct support.